

SF28HCBATDMHL

*Freezer Merchandiser
With Health Lock Timer*

Project Name: _____

Item #: _____ Quantity: _____



Integrated Health Lock

Width*	Depth**	Height***	Shelves	Cold Space™	Ship Weight	Ship Cube	Cooling Capacity	Electrical
30 1/2" 775 mm	31" 788 mm	78" 1982 mm	5	28	342 lbs 155 kg	49 cu. ft 1.39 m3	1 HP	115V/6.8 Amp/60 Hz - Single Phase - NEMA 5-15P, Dedicated Circuit

*** Add 3/8" (10mm) for Threaded-In Levelers. Millimeters rounded up.

Premium Features



ProductTemp™



Digitally Controlled

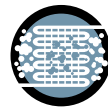

Finless Free&Clear
Condenser Coil



Variable Speed
Compressor



LED Lighting System



Automatic Stainless Steel
Condensate Control System



Priority Air-Flow

SF28HCBATDMHL: Designed to enhance the refrigerated storage or display experience to the highest standards of quality and performance.

Intelligent Health Lock Timer:

- Intelli-Lock System – designed to automatically activate if temp within storage compartment rises above NAMA standard of 0°F (-18°C) for 30 minutes.
- Integrated battery backup allows for continuous monitoring and locking during power outage.
- Restocking Mode – Extends the health lock timer by 75 minutes to avoid nuisance lock outs following restocking mode. Simply press the Up and Down arrows on the digital controller. After 75 mins, the controller and lock will return to standard operational settings.
- Dual Temperature Probes – Glycol bottle probe ensures most accurate representation of core product temperature and maintains a tight temperature range while standard air temperature probe monitors ambient cabinet temperature, meeting health code requirements.

Refrigeration:

- Advanced variable speed compressor for extended operational life and improved energy efficiency.
- Split forced-air refrigeration system employs R290 refrigerant within a sealed capillary tube system.
- Condensing unit is bottom-mounted and can be accessed from the front for ease of maintenance.
- Priority, directed air flow provides optimum cooling and energy efficiency through front of unit for optimized heat exchange ventilation.
- Finless, Free&Clear Condenser Coil maximizes air-flow over compressor, reduces energy consumption and is non-clogging.
- Corrosion resistant coated evaporator coil.
- Automatic, stainless steel condensate control system.
- Equipped with Energy Efficient Digital Controller featuring visual/audible product protection alarm. Freezers factory preset for -29°C (-20°F).
- Technologically advanced ProcuTemp™ provides exterior product temperature display. Displays to a resolution within 1°.
- Energy-Saving, Time-Initiated, Temperature-Terminated Defrost System with Evaporator Fan Motor Delay during Defrost and Fan Motor Interrupt on Door Opening. Features Manual Defrost Override.
- Quality, self-lubricating and sealed motors with streamlined air-flow provide quieter yet robust refrigeration.
- Equipped with Digital Thermometer.

Cabinet:

- Exterior – durable textured black
- Interior – NSF approved black aluminum liner with stainless steel floor.
- Ergonomic raised interior floor.
- Insulation – cabinet is foamed-in-place with eco-conscious, polyurethane insulation.
- Heavy duty thread-in leveler legs.

Doors:

- Self-Closing Swing Doors feature hold-open position, and spring-back protection.
- Magnetic gaskets are single piece bead-mount construction easily removable for cleaning.
- Low energy, anti-fog film coated and insulated safety glass with black extruded frame, prevents frost.
- Integrated, injection molded pocket handle(s).

Lighting:

- Energy Efficient Full LED Array Lighting System for sparkling Illuminated Interior Display, on Switch.

Storage:

- Five (5) Black coated shelves 25 1/4"W x 22"D (641mm x 559mm) are NSF approved.
- Heavy duty aluminum shelving pilasters will not peel or chip adjustment of 1/2" (13mm) increments.
- NSF-7 compliant for storage or display if pre-packaged aseptic product.

Electrical:

Factory power cord installed for connection to a sole-use (dedicated)
115V/60Hz/1-Phase, 15 Amp circuit.

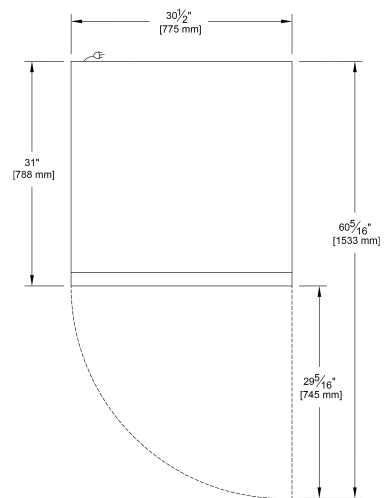
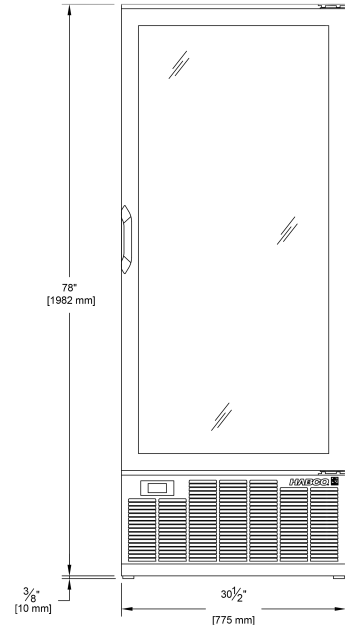

HABCO MANUFACTURING INC. 501 GORDON BAKER ROAD, TORONTO, ONTARIO, CANADA, M2H 2S6
Toll Free CAN: 1-800-387-5398 USA: 1-800-448-0244 Fax: 416-491-6982 www.habcomfg.com