

Premium Product Group

CoolBlu Cooler

Health & Safety Lock Cooler

Service & Manual Parts



750 Morse Avenue, Elk Grove Village, IL 60007, U.S.A.

visit: premiumproductgroup.com | call: 847-709-6299 | email: info@premiumproductgroup.com

INTRODUCTION

Congratulations on the purchase of your cooler. This cooler has been designed to give you many years of dependable service. It requires little maintenance and is easy to set up and operate. This manual contains installation, operation, and service instructions for the CoolBlu Health & Safety Cooler. This manual also contains a parts catalog and electrical schematic for the Cooler.

READ THIS MANUAL COMPLETELY

Your cooler is designed to operate simply and reliably, but to take full advantage of your cooler, please read this owner's manual thoroughly. It contains important information regarding installation and operations, as well as a brief trouble- shooting guide.

EQUIPMENT INSPECTION

After you have received your cooler and have it off the skid, place it on a secure surface for further inspection. Note: Any damages that may have occurred during shipping must be reported to the delivery carrier immediately. Reporting damages and the seeking of restitution is the responsibility of the equipment owner. The factory is willing to assist you in this process in any way possible.

It is important that you keep the original packaging for your cooler at least through the warranty period. If your cooler needs to be returned for repair, you may have to purchase this packaging if it is not retained. Once you have your cooler located, we suggest that you keep this manual for future reference, or you can view this manual online at www.premiumproductgroup.com. Should any problems occur, refer to the section entitled "TROUBLESHOOTING". It is designed to help you quickly identify a problem and correct it.

TABLE OF CONTENTS	
INTRODUCTION	2
SAFETY INFORMATION	4
SAFETY REGULATIONS	5
ELECTRICAL HAZARDS	6
INSTALL AND SETUP	9
INSTALL THE SHELVES	11
ELECTRICAL SUPPLY AND CONNECTIONS	13
REFRIGERATION SYSTEM SERVICE	15
SERVICE AND TROUBLESHOOTING	16
REFRIGERATION CONTROL INFORMATION	19
SERVICE MODE	21
HEALTH AND SAFETY CONTROLLER OPERATION	26
REFRIGERATION SYSTEM TROUBLESHOOTING GUIDE	28
MAINTENANCE	30
EXPLODED VIEWS W/ PARTS LIST	31
WIRING DIAGRAMS - ALL MODELS	38
MANUFACTURER'S LIMITED WARRANTY	42

Serial Number

1st & 2nd Numbers = Week
Manufactured

3rd & 4th Numbers = Year
Manufactured

Model Numbers

ACB305FDP (Full Door/White Interior)
ACB305HDRP (Header/White Interior)
ACB305FDBP (Full Door/Black Interior)
ACB305HDRBP (Header/Black Interior)

Codification

A = New
CB = CoolBlu
30 = 30" Wide
5 = 5 Shelves
FD = Full Glass Door
HDR = Header
B = Black Interior
P = Propane
L = EZ Lift

SAFETY INFORMATION

OUR COMMITMENT TO SAFETY

We are committed to safety with the design of our product. We are committed to notifying the user of any possible danger involving the improper handling or maintenance of our products. The servicing of any electrical or mechanical device involves potential dangers, both to those servicing the equipment and to users of the equipment. These dangers can occur because of improper maintenance or usage. The purpose of this safety segment is to alert anyone servicing the cooler of potentially dangerous areas and to provide basic safety guidelines for proper upkeep.

This service manual contains various warnings that should be carefully read to minimize the risk of personal injury. This manual also contains service information to ensure that proper methods are followed to avoid damaging the cooler or making it unsafe. It is also important to understand these warnings provide general guidance only. PPG could not possibly know, evaluate, or advise of all the conceivable ways in which service might be done. Consequently, PPG cannot predict all of the possible dangerous results. These outlined safety precautions are the basis for an effective safety program. Use these safety measures, along with the service bulletins, helpful hints, and product specification sheets, when installing or servicing PPG equipment.

We recommend that persons servicing our cooler maintain a similar commitment to safety. Only personnel properly trained should have access to the interior electrical and / or mechanical parts of the cooler. This will minimize the potential dangers that are inherent in electrical and mechanical devices. PPG has no control over the cooler once it leaves the premises. It is the owner or lessor's responsibility to maintain the cooler in a safe condition. See installation insert located in the new cooler for proper installation procedures and refer to the service manual for recommended maintenance procedures. If you have any questions, please contact PPG at 847-709-6299.

SAFETY REGULATIONS

- Read the safety segment before installation or service.
- Disconnect the power cord from the wall outlet before servicing the cooler.
- Only fully-trained service technicians should service the cooler when it has power.
- Remove any product before moving a cooler.
- Use appropriate equipment when moving a cooler. Always wear eye protection, and protect your hands, face, and body when working near the refrigeration system.
- Use only original manufacturer authorized replacement parts.
- Be aware of inherent dangers in rocking or tipping a cooler.

ELECTRICAL HAZARDS GENERAL ADVICE

Careless or improper handling of electrical circuits can result in injury or death. Anyone installing, repairing, loading, opening, or otherwise servicing a cooler should be aware of this precaution. Apply all of the normal precautions when handling electrical circuits, such as:

- Refrigeration servicing to be performed by qualified personnel only.
- Unplug the cooler before servicing.
- Replace electrical cords if there is any evidence of fraying or other damage.
- Keep all protective covers and ground wires in place. Plug cooler into outlets that are properly grounded and polarized (where applicable) and protected with fuses or circuit breakers of the correct size.
- All electrical connections must be dry and free of moisture before applying power.

WARNING: ALWAYS TEST TO VERIFY PROPER GROUNDING PRIOR TO INSTALLATION IN ORDER TO REDUCE THE RISK OF ELECTRICAL SHOCK AND FIRE.

ELECTRICAL HAZARDS

1. Servicing with power off.

For maximum safety, unplug the power cord from the wall outlet before servicing. This will aid in avoiding electrical hazards. Service personnel should remain aware of possible hazards from hot components although electrical power is off.

2. Servicing with power on.

Some service situations may require access with power on. Only fully qualified service technicians should perform power-on servicing. Particular caution is required in servicing assemblies that combine electrical power and mechanical movement. Sudden movement (to escape mechanical action) can result in contact with live circuits and vice versa. It is therefore important to maintain maximum clearances from both moving parts and live circuits when servicing.

WARNING

1. ONLY FULLY TRAINED SERVICE PERSONNEL SHOULD ACCOMPLISH SERVICING WITH POWER ON. SUCH SERVICE BY UNQUALIFIED INDIVIDUALS CAN BE DANGEROUS.
2. NEVER USE A HOSE, PRESSURE WASHER, OR ANY CLEANING METHOD THAT COULD WET ELECTRICAL COMPONENTS. IF WATER CONTAMINATION OF ELECTRICAL COMPONENTS IS SUSPECTED, USE QUALIFIED ELECTRICAL TESTING EQUIPMENT AND TEST METHODS TO ASSURE THAT THE COOLER IS NOT A HAZARD BEFORE APPLYING POWER FOR ANY REASON.

This Cooler is intended for the storage and display of non-potentially hazardous bottled or canned products only.

SPECIAL NOTE FOR COOLERS EMPLOYING R290 (PROPANE) REFRIGERANT

1. Component parts must be replaced with like components.
2. Servicing shall be performed by factory-authorized personnel ONLY to minimize the risk of possible ignition due to incorrect parts or improper service.
3. Coolers having flammable refrigerant, such as propane, are not intended for use in lobbies or locations of egress, such as a hallway or public corridor.

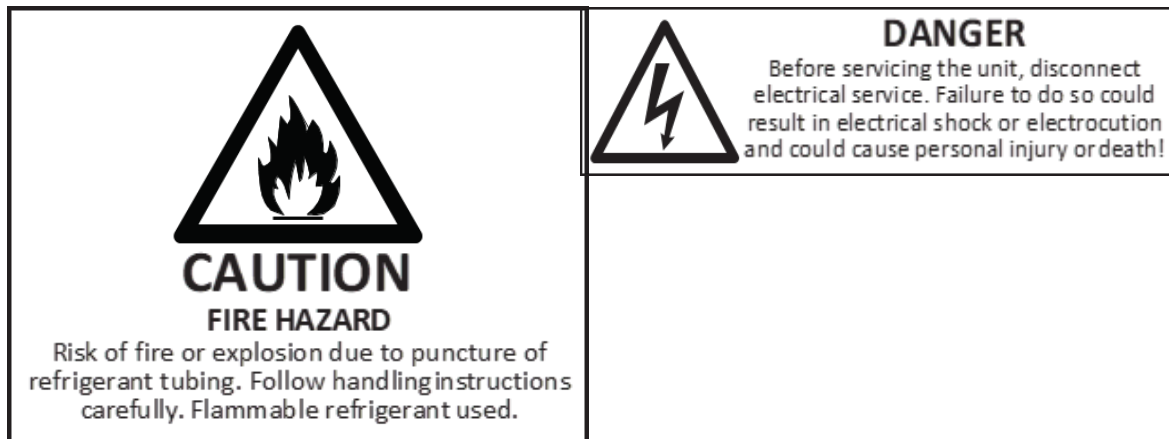

UNPACKING YOUR COOLER

Unwrap the Cooler and then remove the padding checking for any signs of damage. If the Cooler is damaged, contact the carrier immediately. They will instruct you on the procedure for filing a claim.

NOTE: Keys to the Cooler are located on the power cord.

REMOVING THE SHIPPING SKID

Remove from silver plates

PLACING THE COOLER ON LOCATION

When placing the Cooler on location, please allow for a minimum of four inches or 10 cm of space at the back of the vendor. This will allow for the proper ventilation of the refrigeration system.

LEVEL THE COOLER

Using a crescent wrench & a level adjust the leg levelers until the Cooler is balanced and even. Not properly balancing the Cooler could result in tipping and improper sealing of the glass door.

VOLTAGE REQUIREMENTS

The merchandiser is designed to operate at a voltage of 115 volts, 60 hertz.







COOLER POWER CORD

There are three grounding cords. Please make sure that the Cooler is plugged into a grounded electrical outlet in order to prevent an electrical shock.

Note: The usage of an extension cord is not recommended unless authorized prior to use by a certified electrician.

INSTALL AND SETUP



 Press & Hold	<p>Behind the CoolBlu logo is a hidden button. When pressed for different lengths of time, it will perform different functions.</p> <p style="text-align: center;">Function</p>
3 Seconds	<p>Initial Setup & Reset of Health & Safety Lock Release after the <u>Horizontal Bar</u> lights up the bottom. This unlocks the door and turns on the LED Lights. <i>(Needs to be done after every power outage)</i></p> 
5 Seconds	<p>Release after <u>Vertical Bar</u> lights up at bottom left. This allows you to Test the Health & Safety Lock</p> 
8 Seconds	<p>Release after the <u>Vertical Bar</u> lights up the bottom right. This allows you to change from Health Cooler to Beverage Cooler</p> 
Press 3 Times	<p>User interface will scroll the following: dO = Door openings in last 24 Hrs Ht = Highest Temp reached in last 24 Hrs Tn = Time Cooler was at Highest Temp Po = Times Power went OFF in last 24 Hrs rC = Compressor run time</p>
To change the set temperature	<p>Press  OR  for 1 second. The set point will start flashing Increase or Decrease the Value using the UP and DOWN arrows Press SET to confirm the new value Factory set point is 36 degrees The set point can be adjusted from 34.0 F to 65 F ONLY APPLIES WHEN USING AS A BEVERAGE COOLER</p>
<p style="text-align: center;">For Technical Assistance please call: 847-709-6299 or View YouTube Videos @: www.premiumproductgroup.com</p>	

IN ORDER TO BE IN COMPLIANCE WITH THE NSF STANDARD 7. PLEASE EMPLOY ONE OF THE FOLLOWING MOUNTING OPTIONS

CABINET SEALED TO THE FLOOR – OPTIONAL

PPG Coolers are designed with flush bases to allow sealing to the floor where required. To seal the cabinet to the floor, follow these procedures:

1. Allow 1” clearance at rear of cooler for power cord. Disconnect power to cooler.
2. Level the cooler front to back and side to side.
3. Draw an outline of the base of the cabinet on the floor.
4. Lift cooler up.
5. Apply an adequate amount of “NSF Approved Sealant” (Refer to <http://www.nsf.org/>) at about 0.5” inside the drawn outline.
6. Lower the cooler back down.
7. Ensure that all gaps and openings between the bottom perimeter of the refrigerator and floor are sealed without gaps.
8. Connect the appliance to power.

CASTER KIT INSTALLATION – OPTIONAL

PPG Coolers may be equipped with an optional caster kit. to install caster kit, follow these procedures:

1. Disconnect power and lift the cooler up.
2. Twist levelers counterclockwise to loosen and remove.
3. Install non braking caster at rear of the cooler by threading into existing leg leveler leg hole.
4. Install braking casters at front of the cooler by threading into existing leg leveler hole.
5. WHEN ROLLING COOLER INTO POSITION, ENSURE THE FRONT CASTERS EXTEND OUTWARD FROM THE CABINET FACE.
6. Position the cooler according to PPG install guide and connect power.
7. When in place, engage brakes on the front casters.

LEG KIT INSTALLATION – OPTIONAL

PPG Coolers may be equipped with an optional leg kit to provide a minimum unobstructed clearance

of 6" beneath the unit. To install leg kit, follow these procedures:

1. Disconnect power and lift the cooler up.
2. Twist levelers counterclockwise to loosen and remove.
3. Thread legs from kit into existing leveler holes.
4. Level the cooler front to back and side to side using the end of the leg to adjust.
5. Position the cooler according to PPG install guide and connect power.

To level the unit:

The door is spring-loaded and will not function properly without proper leveling of the cabinet. Using an adjustable wrench, adjust the leveling legs so that the unit sits approximately level to the floor and the door closes properly. For best door operation, adjust the leveling legs so that the cabinet has a 1/16" (2 mm) rake or slant from front to rear. Optional casters are available to replace the leveling legs

INSTALL THE SHELVES

Product shelves and a parts package containing shelf support clips and wall spacer are packed inside the unit. Refer to the table below to verify the quantity of shelves and shelf supporting clips.

To install the shelves:

1. Determine the proper location for the shelf clips. Refer to the numbers on the pilaster to ensure that all clips are properly located.
2. Insert the top tab of the shelf clip into the desired hole of the pilaster. The retaining tab should be facing upward, as shown in Figure 2.
3. Rotate the clip downward and insert the bottom tab into the appropriate hole on the pilaster. If necessary, squeeze the clip slightly during installation.
4. Install all remaining clips as described above.
5. Install the shelves onto the clips so that the product retention bars are facing upward. Be careful not to dislodge the clips during shelf installation.

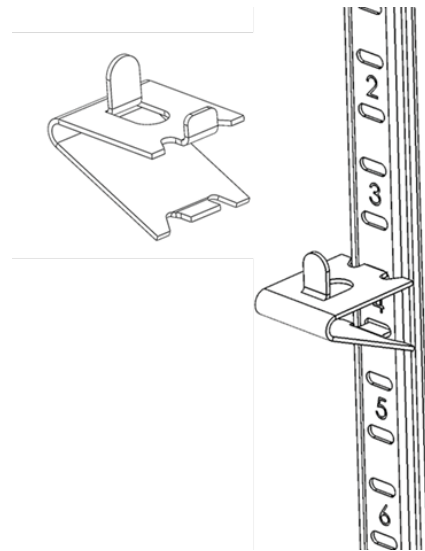

6. Shelves must be placed so that the retaining tab on the shelf clip captures the shelf, as shown in Figure 3.
7. Before loading the shelf, ensure that the shelf is resting on each of the four clips and that the clips are installed as shown in Figures 2 and 3.

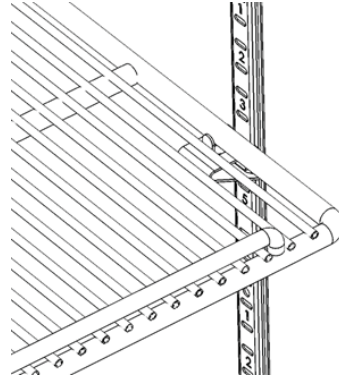

Figure 3. Proper installation of the shelf on the clip.

CONDENSATE DISPOSAL

The evaporator drain pan is located in the base of the refrigeration deck. Airflow in the deck compartment hastens condensate evaporation so that external drain plumbing is not required.

ELECTRICAL SUPPLY AND CONNECTIONS

Check to be sure that the electrical service to the unit meets all local and national electrical codes. Unit electrical data is shown on the unit data label, located on the inside of the cabinet in the upper left-hand corner. Review this label before initiating electrical service. The voltage range of the power supply to the unit should be 105 to 125 volts. Refer to the table below for unit data.

NOTE: Other motors or heavy appliances should not be used on the same circuit with the cooler.

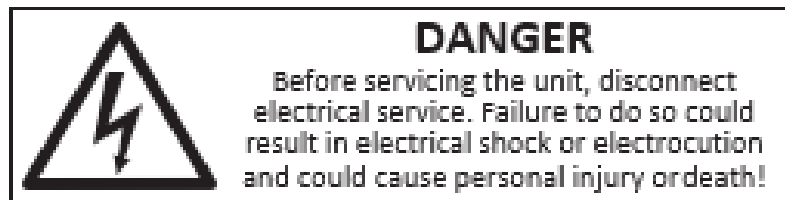

INITIAL START-UP

Power Supply

Connect the unit to the power supply. Check to verify that the compressor, LED's, and fans are running

IMPORTANT: *Low line voltage is often the cause of service complaints. Check to see that the line voltage is within the specified range with the unit running.*

Voltage AC Nominal Range	Frequency	Total Amps	Refrigerant Type Charge Amount	Design Pressure High Side / Low Side (psi)
115 (105-125)	60 Hz	3.0	R290 3.17 oz. (82 g)	244 / 140

SETUP RECOMMENDATION

1. To ensure proper operation, Coolers should be allowed to run under normal operating conditions for a minimum of four hours before placement at customer locations.
2. After placement at the customer location, it is recommended that the unit is powered up and allowed to operate until the following day before filling the unit with product. This will ensure the unit has pulled down and is operating properly, and also ensures that the health timer lock has not engaged during initial pull-down. If the health timer engages during initial pull-down, reset the health timer.
3. Units should be stocked or restocked with product that is below health safety limits (41° F [5° C] or lower) to avoid causing a health timer error. Not following this requirement could cause the health timer to engage due to product being too warm when loaded in the unit.
4. It is possible that a health timer error could be realized after a heavy-usage cycle in combination with extended door-opening times. During such a scenario, the refrigeration system may not pull down to the required temperature within the time limit allowed by the health safety timer, resulting in a health safety error which would require resetting of the health timer. PPG Coolers' recommendation for heavy-usage locations would be placement of additional Cooler to help minimize constant door-openings.

5. If an extension cord is necessary, use only the three-wire grounding type. The use of ungrounded cords or an overloaded circuit voids the compressor warranty.
6. Allow 24 hours between temperature control adjustment. Excessive tampering with the temperature controller could lead to service difficulties.

REFRIGERATION SYSTEM SERVICE

COMPONENTS

The CoolBlu Cooler refrigeration system consists of a hermetically sealed compressor and finned evaporator and condenser coils.

Capillary tube

The capillary tube is located in the refrigerant line between the condenser and evaporator coils. The small-diameter tube is used as a metering device to control the flow of liquid refrigerant to the evaporator coil. This creates low pressure causing the refrigerant to vaporize and absorb heat as it passes through the evaporator coil.

Condenser

The condenser has finned coils which assist in removing heat from the refrigerant. The condenser requires periodic cleaning for maximum efficiency.

Condenser Fan Motor

The condenser fan motor assembly is mounted between the condenser and the compressor. Air is drawn through the condenser, over the body of the compressor, and out the rear of the unit compartment.

The motor is wired to cycle with the compressor, but it will continue to operate should the compressor cut out on the overload. The motor is permanently lubricated; therefore, oiling is not required or recommended.

Drier

The drier is installed in the system just before the capillary tube. The drier traps minute particles of foreign material and absorbs any moisture in the system.

Liquid Control and Heat Exchanger

Liquid refrigerant control to the evaporator of the system is accomplished by the use of a capillary tube. This capillary tube is soldered to the suction line to form a heat exchanger, which sub cools the liquid refrigerant to maintain high

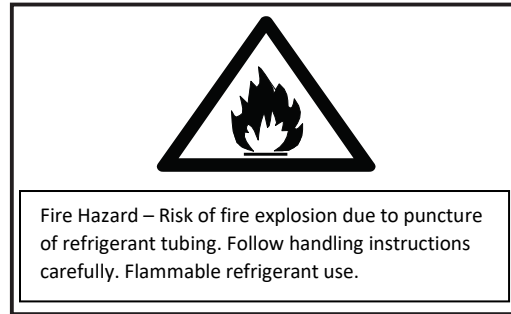

SERVICE AND TROUBLESHOOTING

EZ Lift Refrigeration Deck Removal (Part Number) REI937

Note: The refrigeration deck weighs in excess of 70 lbs. (32 kg). Use caution when lifting the unit.

To remove the refrigeration deck:

1. Remove power from the Cooler.
2. Open door
3. Remove the three screws that secure the grill

- Remove 3 screws

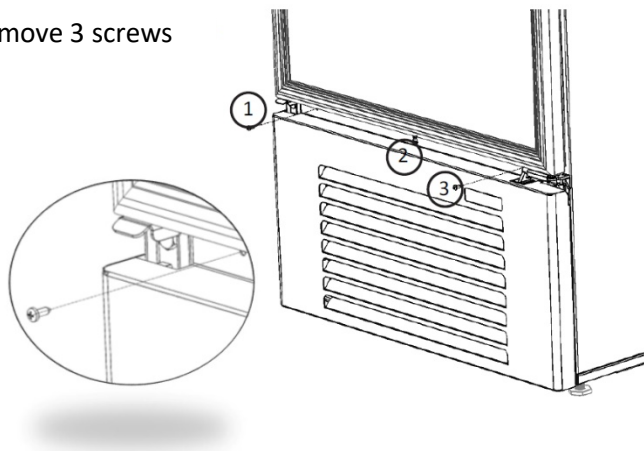

4. Remove the five screws that secure the front shroud.

- Remove 5 screws

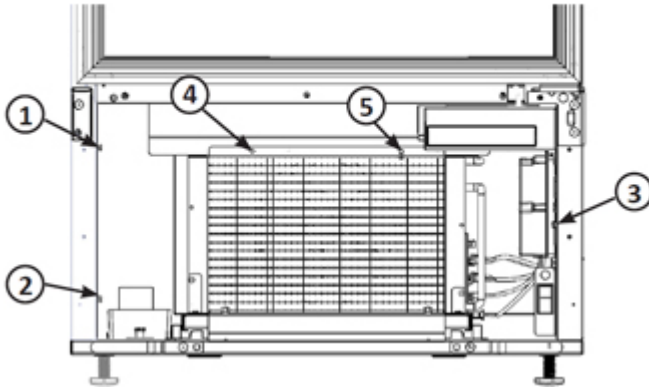

5. Remove the condensate pan by removing thumb screw

Remove thumb screw

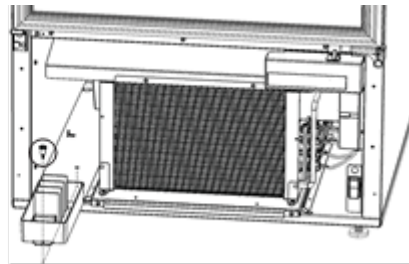

6. Remove the three thumb screws from the user interface.

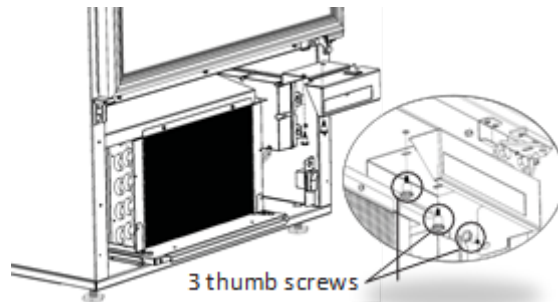

7. Remove the two bolts that secure the unit's base plate

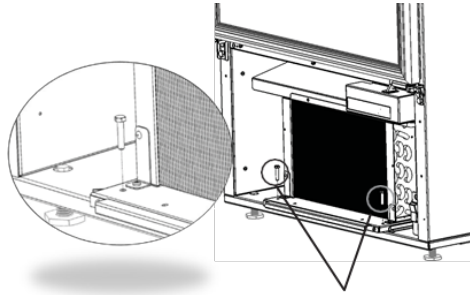

Remove 2 M6 bolts to pull refrigeration deck

8. Remove bolts from EZ lift handles.

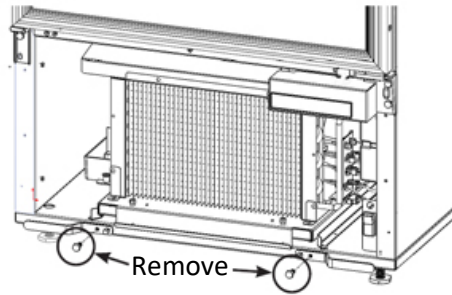

9. Rotate handles up.

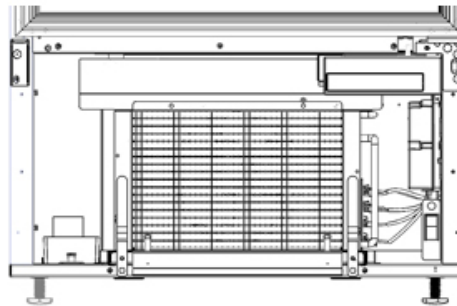

10. Remove handles.

11. Slide the unit approximately half-way out.

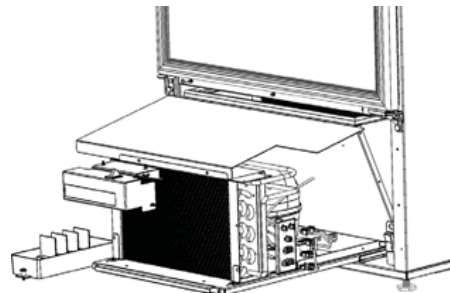

12. Unplug the connectors.

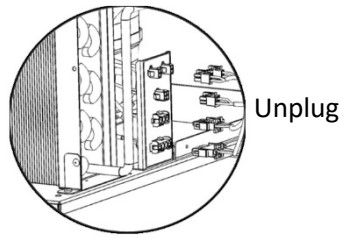

13. Pull the unit completely out.







14. Installation of the new unit is the reverse of the removal process. Ensure that the unit slides within the cassette guides during installation.

REFRIGERATION CONTROL INFORMATION

CONTROL OPERATION



CONTROL FUNCTION GUIDE

FUNCTION	COMMAND	DISPLAY/OPTIONS
Toggle lights	Press  and release	To turn light on/off
Adjust Temperature	Press  or  to adjust set point temperature	Display will show the set temperature.
View temperature in unit	Press  or  together and release	The display will flash and then toggle from set point to temperature in unit. The temperature shown will correspond to the illuminated zone.
Toggle between F/C	Hold  and  for 5 seconds	The display will change units.

DOOR ALERT NOTIFICATION

When the door is left open for more than 5 minutes:

- An audible tone will sound for several seconds every minute.
- “dr” will appear in display.

Close door to silence alert and reset.

1.) Hidden Button

- Accesses Service Menu
- No LED directly above. All LEDs turn on with button activation except #7.

2.) Up Button

- Increases temperature
- Navigates through service menu

3.) Down Button



- Decreases temperature
- Navigates through service menu

4.) Light Button











- Used to select items in service menu

VIEWING ACTUAL TEMPERATURE

In viewing temperature in these modes any offsets are taken into account. This means that if you place a thermistor in a known temperature, let's say ice water, it may not read the 32°F that you would assume. If the control offset was preset at -3°F while you placed the thermistor in an ice bath, the actual thermistor reading when viewing actual temperature would read 35°F. In the unit this would cause the cabinet to push itself 3° cooler. To view pure thermistor readings, you must go into the service menu and choose the correct option.

To view the thermistor temperature, push and release the up  and down  keys. The display will show corrected refrigerator temperature.



SERVICE MODE

This mode has options available for service diagnostics. To enter the mode hold the hidden key () for 10 seconds. This display will show "0." When in this mode use the up  and down  arrows  select the desired option. The LIGHT key  is the ENTER key  and will initiate the function. If changing a setting, you must press the LIGHT key  again to retain the change  setting. To exit the service mode scroll to "0" and press the LIGHT key . After five minutes of not touching  any keys the mode will also exit automatically.

#	Service Mode Menu Item
0	Exit Service Mode
1	View thermistor #1 (no offsets) Cabinet
2	View thermistor #2 (no offsets) Evaporator
3	Adjust thermistor #1 offset - Cabinet
4	Adjust thermistor #2 offset - Evaporator
5	Adjust defrost interval 3 to 24 hours
6	Adjust defrost duration 0 to 99 minutes
7	View error log

#	Service Mode Menu Item
8	Clear error log
9	Adjust thermistor #1 differential
10	Individual component toggle
11	Light all LED segments of display
12	View defrost cycles
13	View compressor run time
14	Activate defrost/harvest
15	Restore factory defaults
16	View software build number of main board
17	View software build number of user interface
18	Evaporator fan toggle

NAVIGATE SERVICE MODE

Use up  or down  arrows to scroll through the menu. Use the light bulb key to enter or exit menu. If values have been changed, they will be saved when exiting

SERVICE MODE GUIDE

1.) THERMISTOR 1 — CABINET

This shows the pure thermistor reading with no offsets taken into account.

2.) THERMISTOR 2 — EVAPORATOR

This shows the pure thermistor reading with no offsets taken into account.

3.) THERMISTOR 1 — CABINET OFFSET

This calibration is only to be used if actual temperature at thermistor #1 is off from set point. By adjusting the offset higher we can force the unit to drive the temperature

down below the set point. (example: adjusting from 0 to +2 will drop the unit temperature 2 degrees)

4.) THERMISTOR 2 — EVAPORATOR OFFSET

5.) ADJUST DEFROST INTERVAL — 3 TO 24 HOURS

This will adjust the interval between defrosts from 3 to 24 hours. Adjusting from the factory settings may cause undesired temperature in the refrigerator section.

6.) ADJUST DEFROST DURATION — 0 TO 99 MINUTES

The length of the defrost can be adjusted 0 to 99 minutes long. The other defrost parameters still apply. Lengthening a defrost may cause higher than normal temperatures in the refrigerator section.

7.) VIEW ERROR LOG

A list of the errors in the order they occurred will scroll once on the display. All errors are logged in memory. Only door error is displayed on the display and has an audible signal.

E0: Door open.

E1: Thermistor 1 open.

E2: Thermistor 2 open.

E3: Thermistor 1 short.

E4: Thermistor 2 shorted.

E5: Door 2 open.

8.) CLEAR ERROR LOG

To clear errors, press and hold  (5 seconds) when CLR is flashing.

10.) THERMISTOR — 1 DIFFERENTIAL

This number should not be adjusted.

INDIVIDUAL COMPONENT TOGGLE

Display #	Relay/Outlet
0	Exit
2	H & S Lock Open
3	H & S Lock Close
4	N/A
5	Evaporator Fan
6	Condenser Fan
7	Compressor
8	LED's
9	N/A

11.) LIGHT ALL LED SEGMENTS

This will illuminate all the LEDs on the display to ensure they work properly

12.) VIEW DEFROST CYCLES

Displays the number of defrosts that have occurred in the past 24 hours

13.) VIEW COMPRESSOR RUNTIME

This will show the number of minutes the compressor has run in the prior cycle (or current cycle if the compressor was running when service mode was entered).

14.) ACTIVATE DEFROST/HARVEST

Turns on the hot gas bypass valve allowing hot gas to circulate through the evaporator causing frost to melt

15.) RESTORE FACTORY DEFAULTS

Will restore all adjustable functions to their factory settings

16.) SOFTWARE VERSION — MAIN BOARD

Displays software version of the main control board

17.) SOFTWARE VERSION — USER INTERFACE

Displays software version of the user interface

18.) EVAPORATOR FAN TOGGLE — USER INTERFACE

0 – Evaporator Fan cycles off with compressor.

1 – Evaporator Fan is always on.

In high humidity and high heat locations (not recommended) the fan will run at all times.

0.) EXIT SERVICE MODE (Beginning)

Thermistors

Thermistors are used for various temperature readings. Thermistors provide reliable temperature readings using a resistance which varies based on surrounding temperatures. If a faulty thermistor is suspected, it may be tested using an accurate ohmmeter.

All thermistors in the unit are identical. If a thermistor is suspected of being defective the resistance can be verified. Place the thermistor in an ice water bath, the resistance should read 16.1k OHMs +/-5% on your meter.

Thermistor connections must be kept clean. A thermistor connection that has become corroded can cause resistance values from the thermistor to change as they pass through a dirty connection to the board.

It is for that reason that we apply dielectric grease to all of our thermistor connections. Dielectric grease will help to keep thermistor connections clean and dry.

If you change a thermistor in the unit, please re-apply dielectric grease to the connection. If you encounter a dirty thermistor connection, you should replace the thermistor and the thermistor harness.

Thermistor error information can be found in the Control Operations - Service section

The unit has two thermistors.

Thermistor 1 (Cabinet):

Located in the evaporator return air flow

THERMISTOR FAILURE





Cabinet Thermistor

If a thermistor(s) in the unit fails, the unit will continue to cool in a backup mode (Self Preservation Mode) to preserve the integrity of the contents. The health and safety lock will automatically activate.

Evaporator Thermistor

If an evaporator thermistor fails, the unit will rely on a preset defrost timer during defrost cycles. The unit will otherwise operate normally. Refer to defrost section.

Setting the set point

- Press   for 1 second. The set point will start flashing after a few moments
- Increase or decrease the value using the UP  or DOWN  buttons.
- Press SET  to confirm the new value.
- Factory set point is 36° F (1° C).
- The set point can be adjusted from 34.0° F (0° C) to 65° F (18° C).

Defrost interval

Either the defrost mode is activated every three hours 20 minutes or the defrost mode is activated every four hours.

Table of alarms

Alarm code	Buzzer and alarm relay	LED	Description	Parameters involved
E0	active	ON	probe 1 error=control	-
E1	inactive	ON	probe 2 error=defrost	[d0 = 0/1]
E2	inactive	ON	probe 3 error-condenser	[A4=10]
IA	active	ON	external alarm	[A4=1] [+A7]
dOr	active	ON	open door alarm	[A4=7/8][+A7]
LO	active	ON	low temp alarm	[AL] [Ad]
HI	active	ON	high temp alarm	[AH] [Ad]
EE	inactive	ON	unit parameter error	-
EF	inactive	ON	operating parameter error	-
Ed	inactive	ON	defrost ended by timeout	[dP] [dt] [d4] [A8]
dF	inactive	OFF	defrost running	[d6=0]
cht	inactive	ON	condenser dirty pre-alarm	[A4=10]
CHt	active	ON	condenser dirty alarm	[A4=10]
EtC	inactive	ON	clock alarm	if bands active

HEALTH AND SAFETY CONTROLLER OPERATION

1. When the controller is first powered up, the Health Safety lock will be locked and cabinet lights off. This is intended to prevent access to spoiled food or drinks whenever the previous state of the refrigeration is unknown.
2. To reset the Health Safety error, press the CoolBlu for 3 seconds.
3. Upon reset, the controller will enter a “grace” period. At the end of this grace period, the controller will sample the cabinet temperature to see if the temperature is below 41°F (5° C). The length of this grace period is determined by the state of the door switch at the time the reset button is pressed.
 - A. If the door is open at the time of reset, the controller will allow a 60-minute grace period.
 - B. If the door is closed, the controller will allow a 30-minute grace period.
 - C. If at the end of either grace period (30 or 60 minutes) the temperature is not below 41°F (5° C), the controller will trigger a Health Safety error, supply (-) 24VDC to lock the door, and the diagnostic LED will indicate a Health Safety error.

4. The controller constantly monitors the state of the door switch. If the controller determines that the door switch has cycled (i.e., from closed to open or open to closed), the controller will begin a grace period. The length of this grace period will depend upon the state of the door after the transition has occurred.
 - A. The controller will initially allow a 30-minute grace period.
 - B. If the door again cycles during the timeout period, the grace period will be reset.
 - C. At the end of the grace period, the cabinet temperature must be at or below 41°F (5°C). If the temperature is above 41°F (5°C), the Health Safety error will trigger and supply (-) 24VDC to lock the door AND the LED Lights will turn OFF. If the temperature is below 41°F (5°C), normal operation will resume.

5. The controller constantly monitors the AC power through an AC power detector circuit. When AC power is disrupted, the controller will shed all loads (LED, sensors, etc.), immediately supply (-) 24VDC to the solenoid from a capacitor or battery to lock the door, and enter into a low-power state of operation. The controller will remain in this low-power state for 30 minutes or until AC power returns. If AC power returns before the 30-minute timeout period has expired, the controller will sample the temperature upon power-up.
 - A. If the temperature is below 41°F (5° C), the controller will return to normal operation and supply (+) 24VDC to unlock the door.
 - B. If the temperature is above 41°F (5° C), the controller will trigger the Health Safety error and supply (-) 24VDC to lock the door (to ensure the door is still locked) AND turn off the LED Lights.
 - C. If power is not restored within the 30-minute timeout period, the controller will trigger the Health Safety error and enter into stop mode.

REFRIGERATION SYSTEM TROUBLESHOOTING GUIDE

CONCERN	POTENTIAL CAUSE	SUGGESTED REMEDY
Compressor will not turn ON; does not make a pulsing sound.	1. Power cord not plugged in.	1. Plug in the cord.
	2. Wiring improper or loose.	2. Check wiring against schematic.
	3. Test overload and relay, replace as needed.	3. Faulty overload and relay to be replaced.
	4. Confirm proper compressor operating voltage.	4. Input supply as per nominal rated supply.
Compressor will not start; makes a pulsing sound but trips on overload protector.	1. Under voltage to unit.	1. Determine reason and correct.
	2. Run capacitor defective.	2. Replace the capacitor.
	3. Confirm condenser fan operation.	3. Troubleshoot condenser fan.
	4. Compressor overheating	4. Verify proper air flow through condenser.
	5. Improperly wired.	5. Check wiring against schematic.
Compressor turn ON but does not switch to Run winding.	1. Under voltage to unit.	1. Diagnose reason and correct to nominal rated voltage.
	2. Run capacitor defective.	2. Replace the capacitor.
	3. Compressor motor winding is defective or shorted.	3. Determine cause, correct, and replace compressor.
	4. Compressor relay defective.	4. Replace the relay
Compressor starts and runs, but trips continuously after short run cycle.	1. Over current passing through overload protector.	1. Check wiring schematic.
	2. Under voltage to unit.	2. Diagnose reason and correct.
	3. Overload protector defective.	3. Check current and replace protector.
	4. Run capacitor defective.	4. Replace the capacitor.
	5. Excessive discharge pressure.	5. Check ventilation, restrictions in cooling medium, restrictions in refrigeration system.
	6. Compressor overheated.	6. Check airflow across condenser.
	7. Excessive ambient	7. Unit placed beside hot burners, change location to ventilated Position.
Frozen Product	1. Control set too cold (Set Point)	1. Adjust Set Point Temp accordingly.
	2. Thermistor failure	2. Check Error Log in Service Mode.

Cabinet temperature too high.	1. Control set too high (Set Point)	1. Adjust Set Point Temp accordingly.
	2. Lower cabinet air circulation.	2. Check operation of evaporator fan motor.
	3. Dirty & blocked evaporator.	3. Clean evaporator.
	4. Dirty & blocked condenser.	4. Clean condenser.
	5. Inadequate air circulation at refrigeration deck.	5. Check condenser fan motor.
	6. Ice formed on Evaporator	6. Check defrost settings. Manual Defrost if required.
Unit operates too long or continuously.	1. Dirty & blocked condenser.	1. Clean condenser.
	2. Cabinet Thermistor Faulty, Shorted or Open	2. Check Thermistor & it's connection. Replace Thermistor if faulty.
	3. Evaporator fan not working.	3. Check evaporator fan wiring. If correct, replace evaporator fan.
	4. Ice formed on Evaporator	4. Check defrost settings. Manual Defrost if required.
	5. Bad refrigeration unit.	5. Replace refrigeration unit.
Frost Buildup On Evaporator	1. Door ajar or restricted from Closing.	1. Check door clearance to adjoining cabinetry. Check distribution of product in unit.
	2. Evaporator fan not operating	2. Check fan wiring. If correct, replace evaporator fan.
	3. Thermistor failure	3. Check Error Log. Replace Defrost Thermistor if gone bad.
	4. Defrost In operational	4. Check defrost settings. Manual Defrost if required.
Unit is noisy.	1. Loose parts or mountings.	1. Find and tighten.
	2. Evaporator fan not operating	2. Carefully reposition tubing.
	3. Thermistor failure	3. Replace blade.
	4. Fan blade obstruction	4. Remove obstruction.
Internal Lights Not Working	1. Health & Safety settings activated	1. Reset Health & Safety
	2. LEDs wiring broken or damaged	2. Perform continuity test of wiring and replace as needed.
	3. LED gone bad.	3. Press and hold Light Key for 5 seconds to check. Replace bad LED.

MAINTENANCE

CONDENSATE REMOVAL

The evaporator drain pan is located in the base of the refrigeration deck. Airflow in the deck compartment hastens condensate evaporation so that external drain plumbing is not required. In general, this renders the condensate pan maintenance-free.

CONDENSER

The condenser should be inspected periodically for accumulation of debris, which should be removed. A vacuum cleaner or plastic bristle brush can be used to remove debris. DO NOT use wire brush. Be careful to not bend the condenser fins.

CABINET EXTERIOR

Cabinets should be cleaned with a solution of mild soap and water or mild household cleaner. Do not use caustic soap or abrasive cleaners, since these might damage the cabinet finish. Do not use steel wool, or rusting might occur.

INTERIOR SURFACE

The inside of the cabinet is coated with powder-coat paint. To clean, use a mild soap and water solution or mild household cleaner.

UNDERNEATH COOLER

Underneath the cooler can be cleaned by hand or by using an appropriate cleaning tool up to 1 1/2" thick. Use a mild soap and water solution or mild household cleaner.

EXPLODED VIEWS W/ PARTS LIST
ASSEMBLY ACB305FDP/ ACB305FDBP

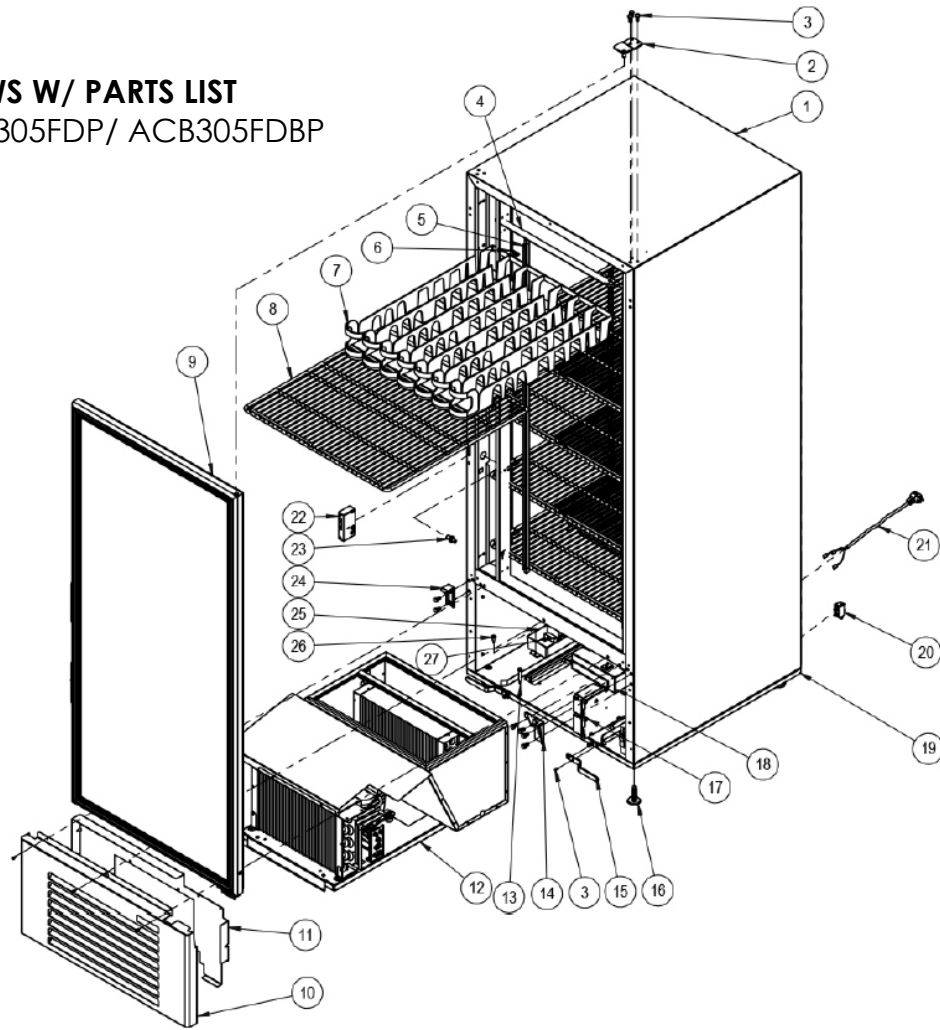

ITEM NO.	PART NO.	DESCRIPTION	QTY.
1	SAI 34002A	CABINET	1
2	STI644	TOP HINGE	1
3	FAI915	BOLT HEX	11
4	ELC2341	LIGHT, LED (VARIES BY NODEL)	1
5	ELC2343	LIGHT, LED	2
6	STI643	PILASTER	4
7		SHELF GLIDE (OPTIONAL)	
8	HAI2072/ HAI2072B	SHELF, WHITE/BLACK	5
9	SAI34012A	DOOR	1
10	STI34069	GRILL	1

ITEM NO.	PART NO.	DESCRIPTION	QTY.
11	STI34069	COVER, REFRIGERATION DECK	1
12	REI937	REFRIGERATION DECK	1
13	HAI2080	STEP SCREW	2
14	STI645	BOTTOM HINGE	1
15	STI649	HANDLE, LIFTING	2
16	HAI955	LEVELER	4
17	SAI34024	CONTROLLER ASSEMBLY	1
18	SAI34026	USER, INTERFACE ASSEMBLY	1
19	SAI34007A	BASE, ASSEMBLY	1
20	ELC946A	FILTER	1

ASSEMBLY ACB305FDP/ ACB305FDBP CONTINUED

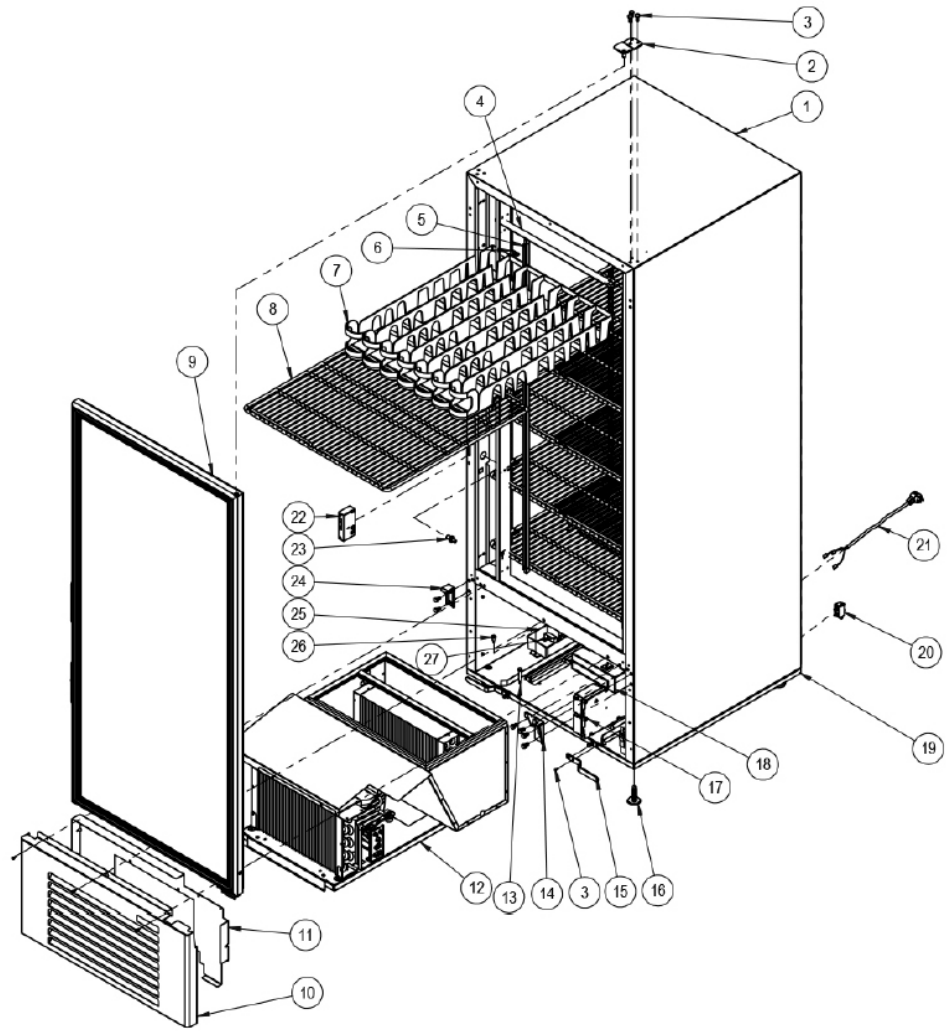

ITEM NO.	PART NO.	DESCRIPTION	QTY.
21	ELC348A	POWER CORD	1
22	ELI2402	SOLENOID, LOCK	1
23	PLI2215	LOCK RELEASE BUTTON	1
24	STI34074	DOOR STAY	1

ITEM NO.	PART NO.	DESCRIPTION	QTY.
25	PLI612	CONDENSATE TRAY	1
26	PLI613	SCREW, KNOB	4
27	REC355	WICK SPONGE	4

ASSEMBLY ACB305HDRP/ACB305HDRBP

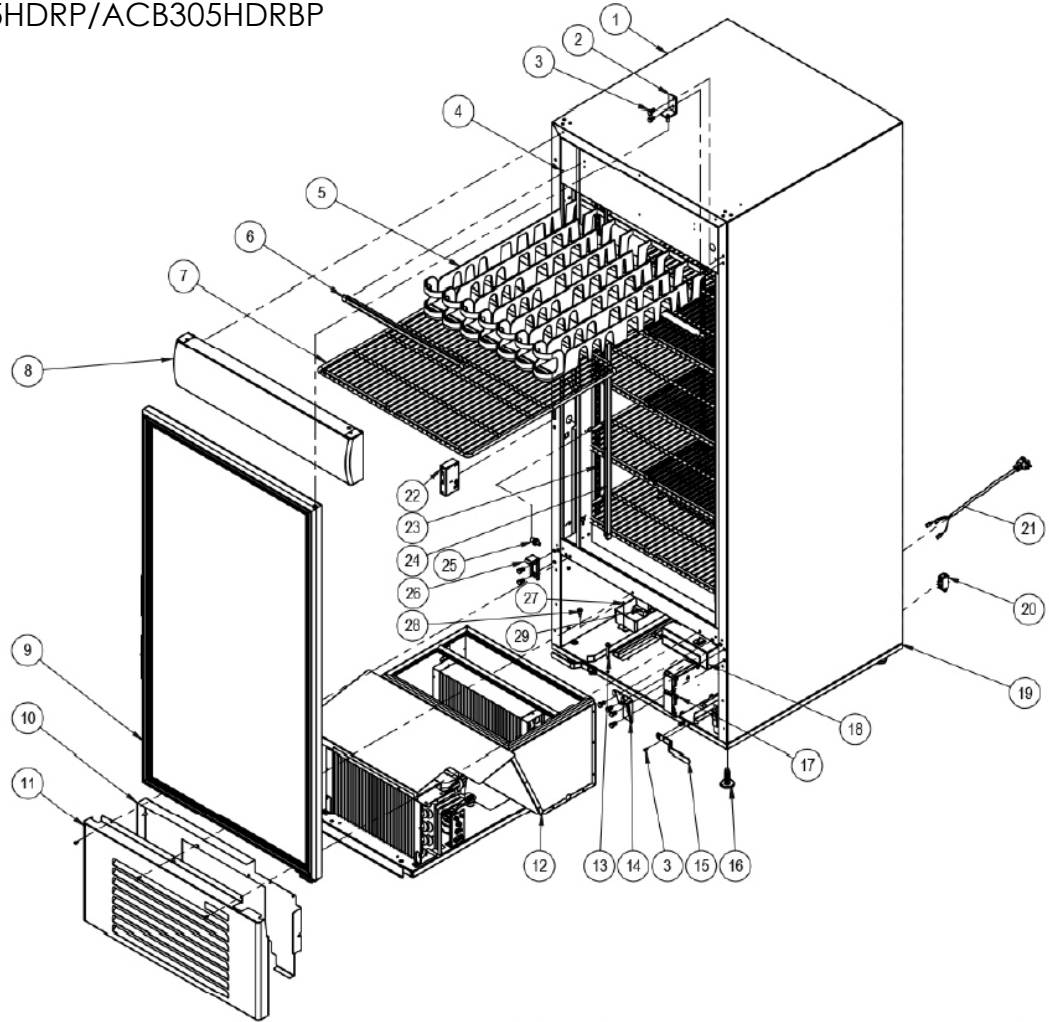

ITEM NO.	PART NO.	DESCRIPTION	QTY.
1	SAI 34002A	CABINET	1
2	STI600A	TOP HINGE	1
3	FAI915	BOLT HEX	8
4	SAI34015	CANOPY, BASE	1
5		SHELF GLIDE (OPTIONAL)	
6	ELC2341	LIGHT, LED (VARIES BY MODEL)	2
7	HAI2072/ HAI2072B	SHELF WHITE/BLACK	5
8	SAI34022	CANOPY	6
9	SAI34023A	DOOR	1
10	STI34069	COVER, REFRGERATOR	1

ITEM NO.	PART NO.	DESCRIPTION	QTY.
11	STI34046A	GRILL	1
12	REI37	REFRIGERATION DECK	12
13	HAI2080	STEP SCREW	13
14	STI645	BOTTOM HINGE	14
15	STI649	HANDLE, LIFTING	2
16	HAI955	LEVELER	4
17	SAI34024	CONTROLLER ASSEMBLY	1
18	SAI34026	USER INTERFACE ASSEMBLY	1
19	SAI34007A	BASE, ASSEMBLY	1
20	ELC946A	FILTER	1

ASSEMBLY ACB305HDRP/ACB305HDRBP CONTINUED

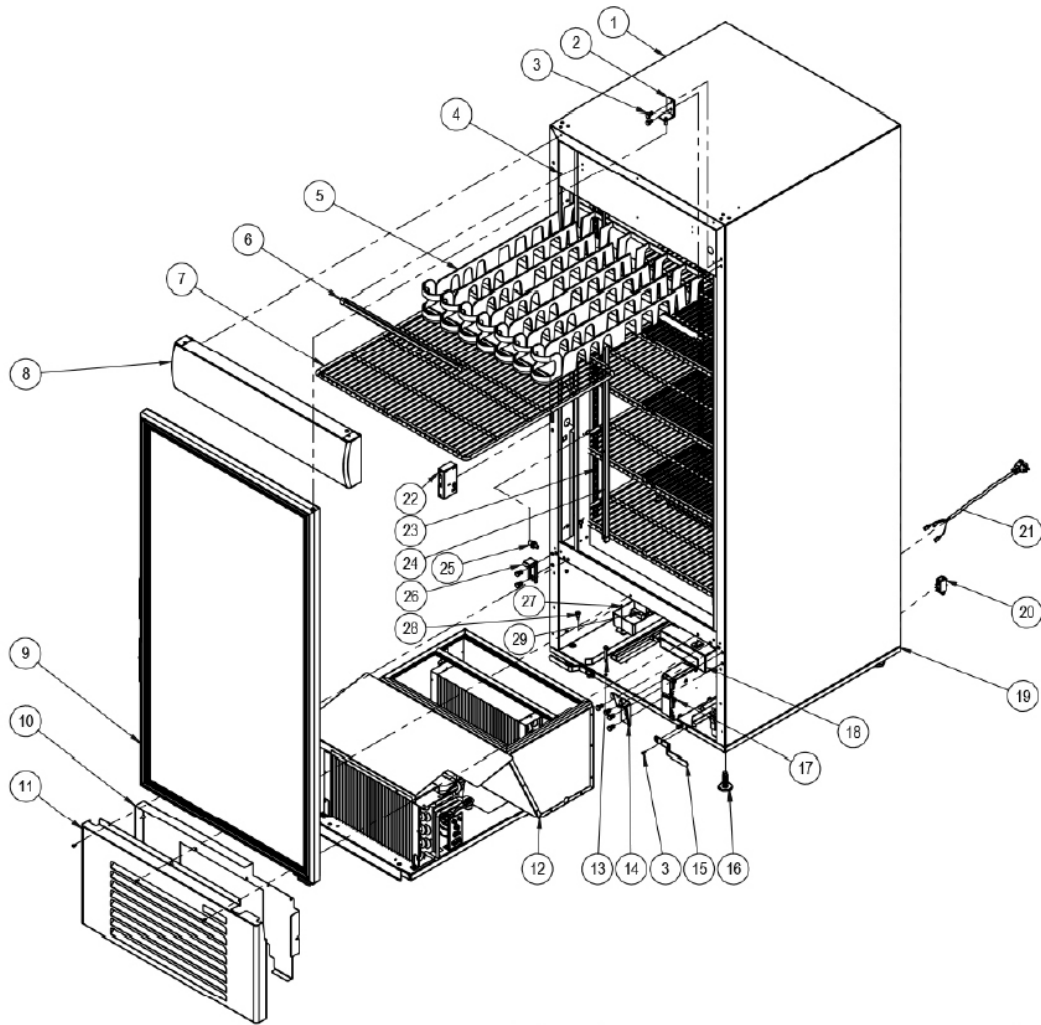

ITEM NO.	PART NO.	DESCRIPTION	QTY.
21	ELC348A	POWER CORD	1
22	ELI2402	SOLENOID, LOCK	1
23	STI642	PILASTER	4
24	ELC2344	LIGHT, LED	2
25	PLI2215	LOCK RELEASE BUTTON	1

ITEM NO.	PART NO.	DESCRIPTION	QTY.
26	STI34074	DOOR STAY	1
27	PLI612	CONDENSATE TRAY	1
28	PLI613	SCREW KNOB	4
29	REC355	WICK SPONGE	4

DOOR ACB305FDP/ ACB305FDBP

ITEM NO.	PART NO.	DESCRIPTION	QTY.
1	GLI968	GLASS DOOR	1
2	PLI2218	DOOR, PROFILE RH	1
3	PLI2218A	DOOR, PROFILE LH	1
4	PLI2212	DOOR, PROFILE TOP	1
5	PLI2212A	DOOR, PROFILE BOTTOM	1
6	PLI2214	GASKET	1
7	HAI2082	BUSHING	2
8	STI21047	BRACKET, DOOR CORNER	4
9	PLI2122	HANDLE	1
10	STI34068	DOOR SWITCH, BRACKET	1
11	STI34063	REINFORCEMENT, DOOR	1
12	FAI941	SCREW	2
13	FAI987	SCREW	4
14	FAI872	SCREW	18
15	STI595A	DOOR STOP	1
16	PLI2184A	CORNER, JOINT DOOR, BOTTOM	2
17	PLI2185A	CORNER, JOINT DOOR, TOP	2
18	PLI2240	PLUG, PICO	1
19	ELI2415	HARNESS PICO	1
20	ELI2419	HARNESS ANTENNA	1
21	SAI34013	LOCK ASSEMBLY	1

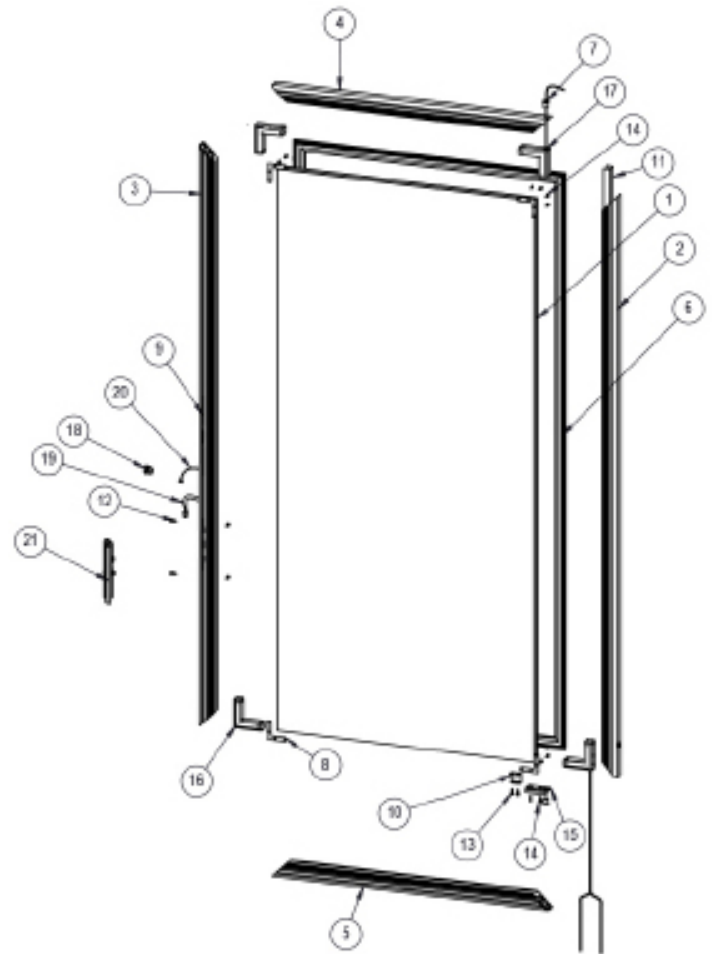

DOOR ASSEMBLY ACB305HDRP/ACB305HDRBP

ITEM NO.	PART NO.	DESCRIPTION	QTY.
1	GLI968	GLASS DOOR	1
2	PLI2219	DOOR, PROFILE RH	1
3	PLI2219A	DOOR, PROFILE LH	1
4	PLI2212A	DOOR, PROFILE BOTTOM	1
5	PLI2212	DOOR, PROFILE TOP	1
6	PLI2220	GASKET, DOOR	1
7	HAI2082	BUSHING, HINGE	2
8	STI595	STOP, DOOR	1
9	STI21047	BRACKET, DOOR CORNER SUPPORT	4
10	PLI2184A	CORNER JOINT, DOOR, BOTTOM	2
11	PLI2185A	CORNER JOINT, DOOR, TOP	2
12	PLI2122	HANDLE	1
13	STI34068	BRACKET, DOOR SWITCH	1
14	STI34064	REINFORCEMENT, DOOR	1
15	FAI941	SCREW	2
16	FAI987	SCREW	4
17	FAI872	SCREW	18
18	SAI34013	LOCK ASSEMBLY	1
19	PLI2240	PLUG, PICO	1
20	ELI2415	HARNESS PICO	1
21	ELI2419	HARNESS ANTENNA	1

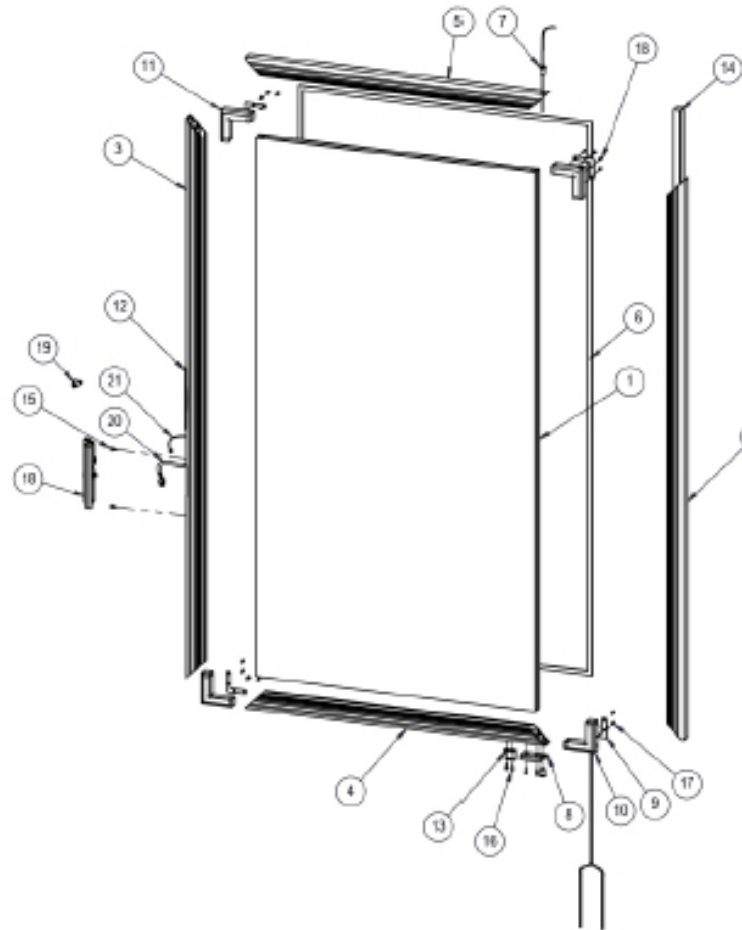

REFRIGERATION DECK ASSEMBLY GENERATION 1, 2, & 3 - REI832
 EZ LIFT REFRIGERATION DECK ASSEMBLY GENERATION 4 – RE937

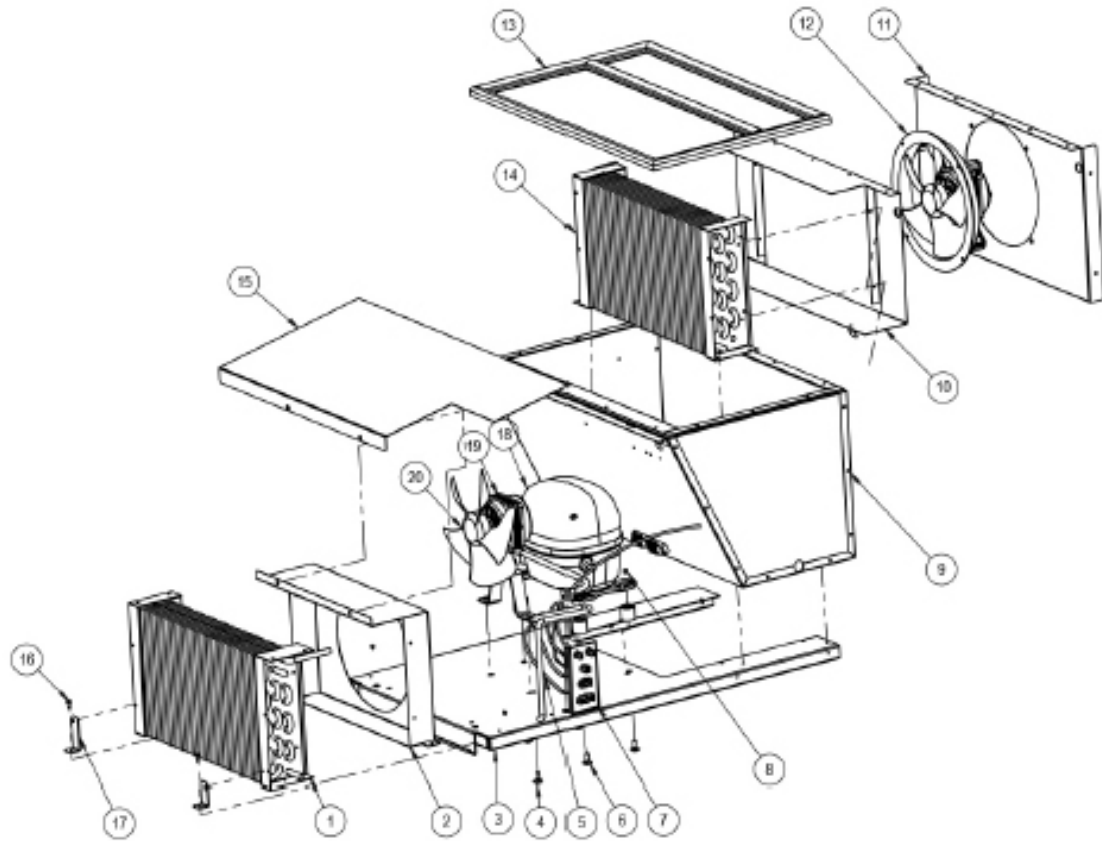

ITEM NO.	PART NO.	DESCRIPTION	QTY.
1	REC926	CONDENSER	1
2	STI34033	SHROUD, CONDESNER	1
3	STI34025	BASE, REFRIGERATION DECK	1
4	FAI972A	BOLT, CARRIAGE	2
5	ELI2389B	HARNESS	1
6	FAI854	BOLT, CARRIAGE	4
7	STI34086	BRACKET, CONNECTOR	1
8	FAI923	NUT, NYLOCK	6
9	SAI34D16	REFRIGERATION DECK, FOAMED	1
10	STI34035	BRACKET, EVAPORATOR	1

ITEM NO.	PART NO.	DESCRIPTION	QTY.
11	STI34034	SHROUD, EVAPORATOR	1
12	PLI955	BRACKET, MOTOR	1
13	PLI2217	GASKET, REFRIGERATION DECK	1
14	REC927	EVAPORATOR	1
15	STI34038	COVER, REFRIGERATION DECK	1
16	FAI513	SCREW	32
17	STI34041	BRACKET, CONDENSOR	2
18	REI925	COMPRESSOR	1
19	REC861	MOTOR	2
20	REI861	FAN, BLADE	2

WIRING DIAGRAMS – NON-PICO MODELS

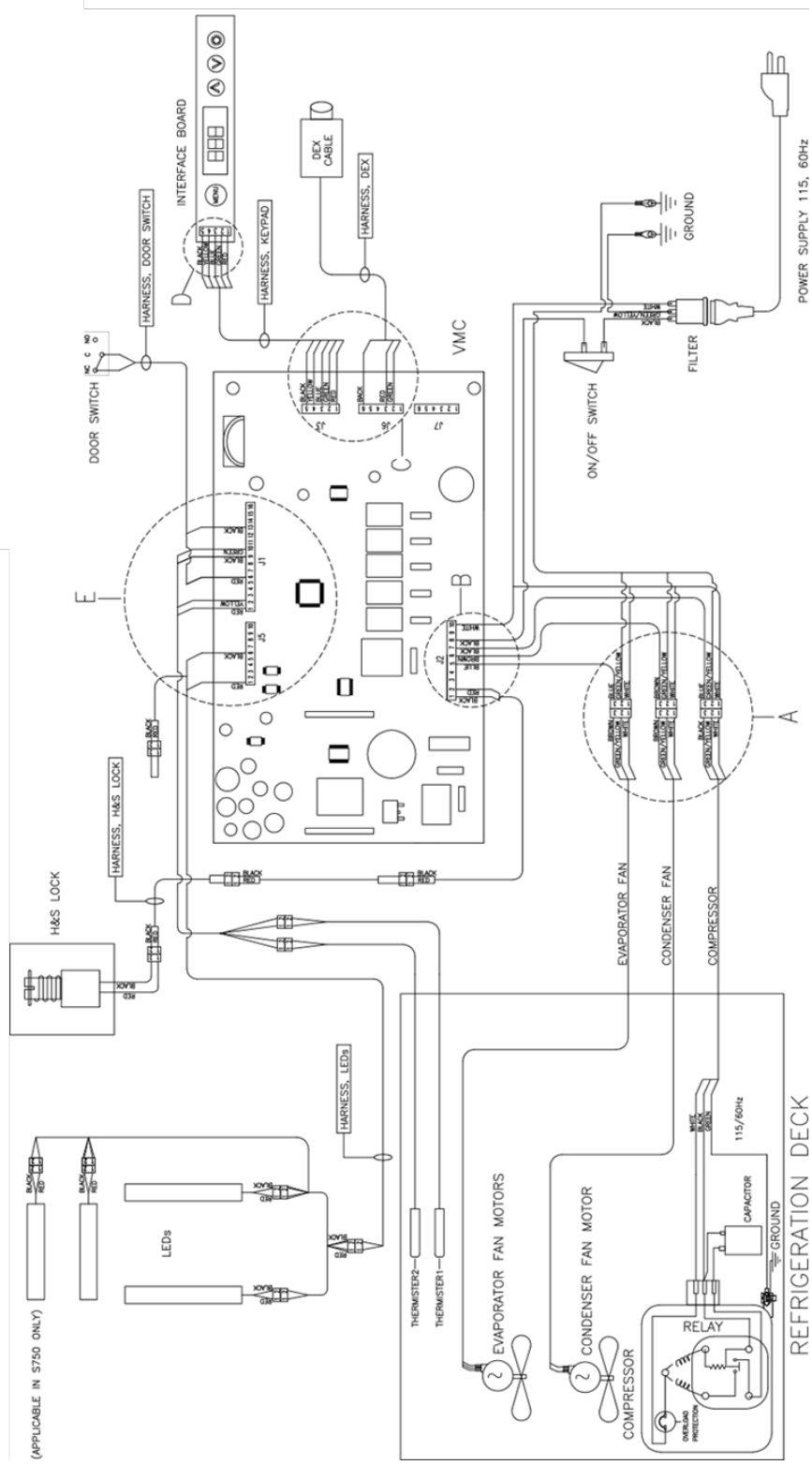

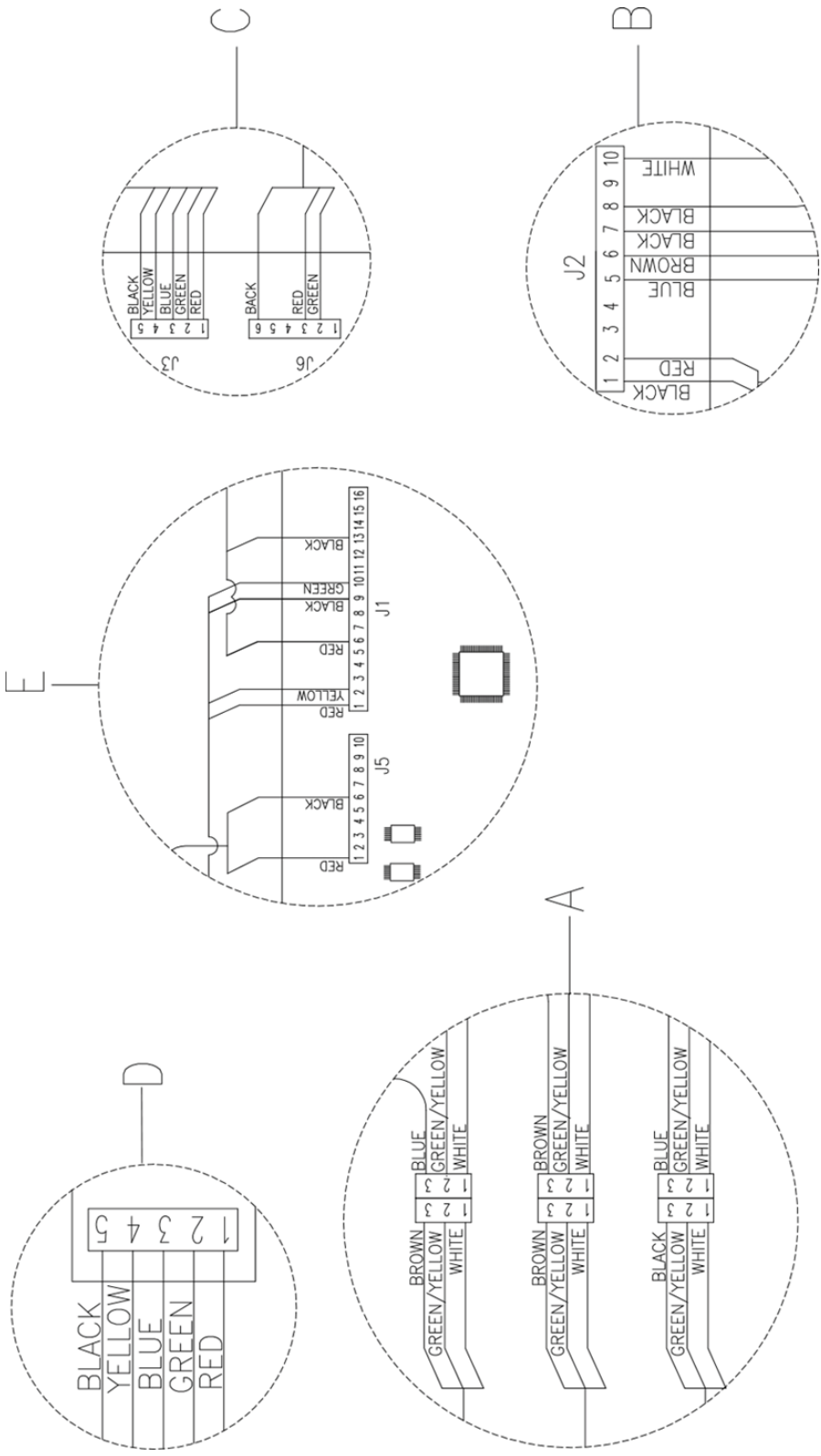

WIRING DIAGRAMS – PICO READY MODELS

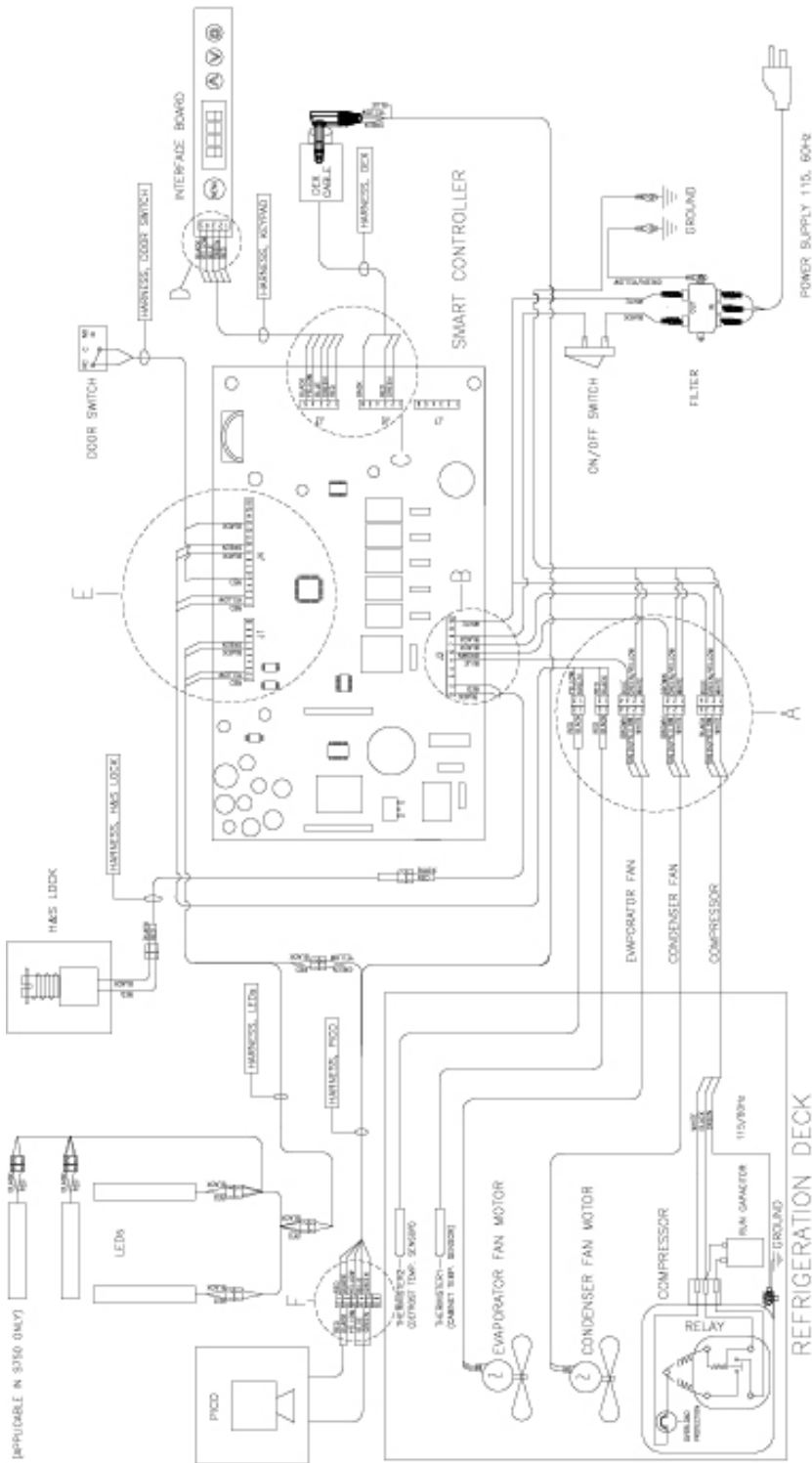

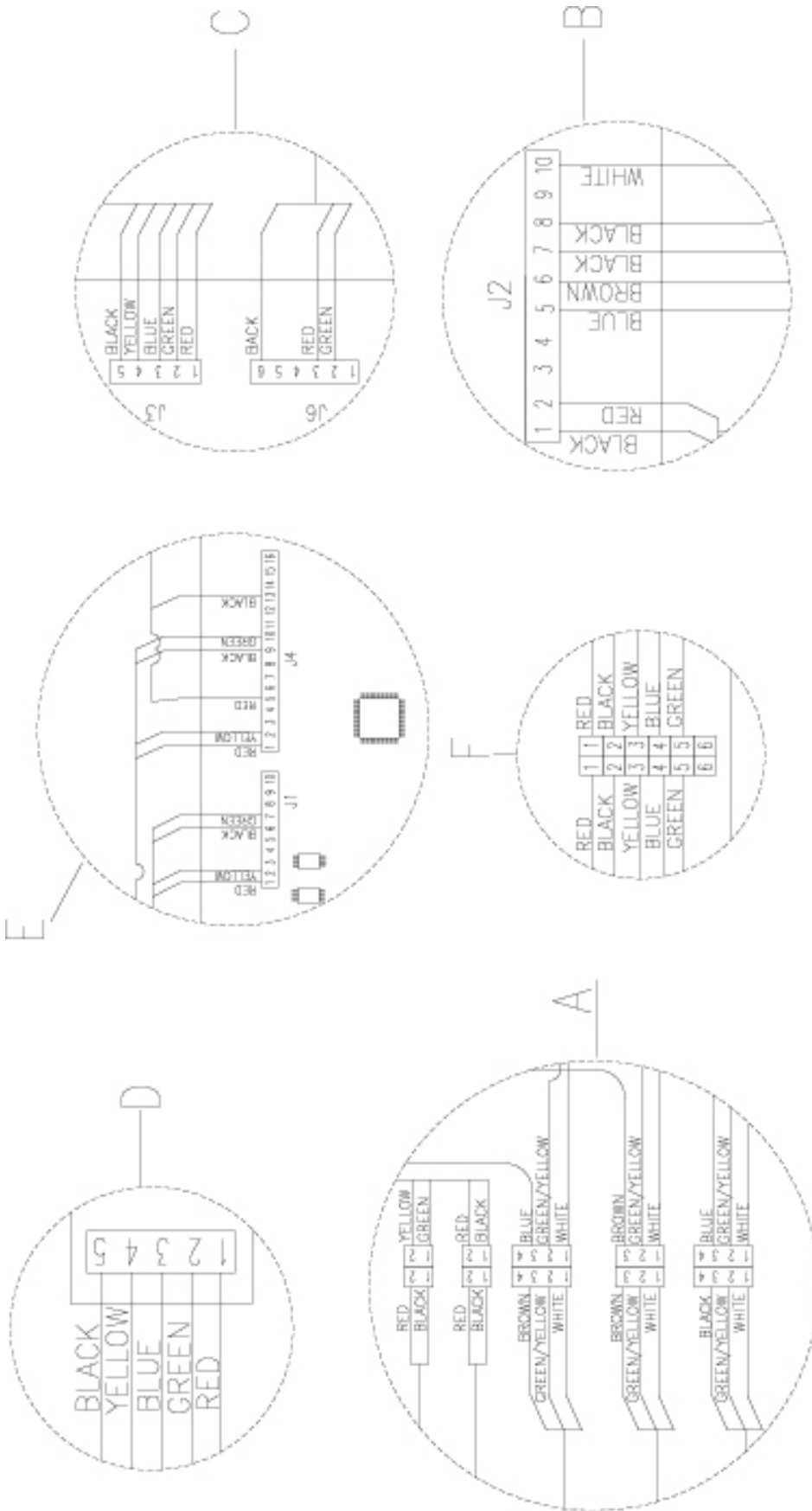

Limited Warranty Statement

Premium Product Group, LLC warrants each of its coolers to the original purchaser for indoor use under the following provisions:

Premium Product Group Limited Warranty

5 Years from date of manufacture - Compressor Dome

3 Years from date of manufacture - Refrigeration system consisting of the evaporator and condenser fan motors, evaporator, condenser and refrigerant tubing.

3 Years from date of manufacture - Control Board and LED Lighting

1 Year from date of manufacture – All other parts.

Any unauthorized tampering or cutting (tapping) will void the warranty. Accidental damage caused by fire, flood, transportation, civil disorder, or act of God is not covered under warranty.

This warranty applies only if the equipment has been serviced and maintained in material accordance with the instructions presented in the Operator's Manual and no unauthorized service, repair, alteration or disassembly has been performed. Abuse of the product, accident, alteration, vandalism, improper service and maintenance schedules, or damage incurred during return shipment will not be covered by this warranty. Further, equipment that has had the serial number removed, altered or otherwise defaced will not be covered by this warranty. The customer shall be responsible for all cost incurred in the removal, reinstallation and shipping of the product for repairs. Premium Product Group, LLC will assume no liability resulting from improper installation or use of this product. **When contacting Premium Product Group with warranty inquiries you MUST have the Serial Number & Model Number for all coolers.**

In no event, shall Premium Product Group, LLC be liable for any other damage or loss, including but not limited to, lost profits, lost sales, loss of use of equipment, claims of Buyer's customers, cost of capital, cost of down time, cost of substitute equipment, facilities or services, or any other special, incidental or consequential damages.

750 Morse Avenue Elk Grove Village, IL 60007, U.S.A.

Website: avscompanies.com

Phone: 847-709-6299

Email: info@avscompanies.com