

SHARP®

Medium Duty Commercial Microwave Oven

1000
WATTS

1.0
CU.FT.

R21LVF

- 1.0 cu. ft. Capacity, with High Quality Stainless Steel Interior, Exterior, and Door
- Touch Controls: Provides 10 Programmable Memories with One-Second Increment Timing; Built-In Safeguards Prevent Unauthorized Changes
- Express Defrost™: Automatically Divides Total Defrosting Time into 3 Stages with 3 Power Levels
- Double Quantity Pad: Automatically Provides Optimum Heating Times for Two Portions for Excellent Results



FEATURES

Finish	Stainless Steel
Grade	Medium Duty
Oven Control	Touch Pads with Braille
Capacity (cu. ft.)	1.0
Output Power (Watts)	1000
Power Levels	100%
Express Defrost™	Yes
Programmable	Yes, 10 Programmable Memories
Memory Check	Yes
Double Quantity	Yes
Display	Digital
Interior Light	Yes
Door Handle	Trigger Switch
Door, Cabinet, Interior	Stainless Steel
Door Window	See-Through

DIMENSIONS & WEIGHT (In. / lbs.)

Cavity Dimensions (w x h x d)	13-7/8" x 8-1/8" x 14-5/8"
Product Dimensions (w x h x d)	20-1/2" x 12-1/8" x 16"
Product Weight / Shipping Weight	37 lbs / 44 lbs

ADDITIONAL SPECIFICATIONS

AC Power Required	120V, 60Hz, 1.6KW, 14A
NEMA Receptacle	5-15R 
UPC	074000616486

FRONT VIEW

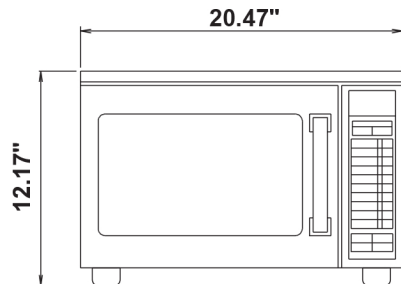

SIDE VIEW

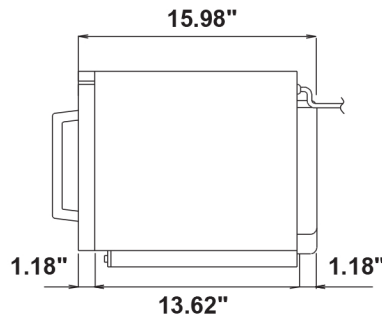

TOP VIEW

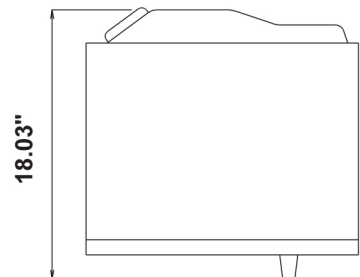

Design and specifications subject to change without notice. Sharp is a registered trademark of Sharp Corporation. SelectaPower, SelectaTime and Express Defrost are trademarks of Sharp Corporation. All other trademarks are the property of their respected owners.



www.avscorporations.com

(847)439-9400 | sales@avscorporations.com