

ESM28HCTD-BLK

Cold Space Merchandiser™

Project Name: _____

Item #: _____ Quantity: _____



Width*	Depth**	Height***	Shelves	Cold Space™	Ship Weight	Ship Cube	Cooling Capacity	Electrical
30 1/2" 775 mm	31" 788 mm	78" 1982 mm	6	28	362 lbs 164 kg	49 cu. ft 1.39 m ³	1/3 HP	115V/10 Amp/60 Hz - Single Phase - NEMA 5-15P, Dedicated Circuit

** Add 1 1/2" (39mm) for Handle. *** Add 3/8" (10mm) for Threaded-In Levelers. Millimeters rounded up.

Shipped less Graphics. Custom Graphics Optional.

Flat Shelf 20oz/600ml		Gravity GlideSet™ 20 oz /600ml		Trailerload Quantity (53')
Packout	Facings	Packout	Facings	
378	9	336	8	57

Premium Features

- 

Cassette® Refrigeration
- 

Finless Free&Clear™
Condenser Coil
- 

LED Lighting System
- 

Automatic Stainless Steel
Condensate Control System
- 

Front Breathing
Refrigeration
- 

Priority Air-Flow
- 

HABCO
Insulated Glass

ESM28HC TD: Designed to optimize merchandising experience to the highest standards of quality and performance.

Refrigeration:

- Self contained Cassette® forced-air refrigeration employs R290 hydrocarbon Natural Refrigerant within a sealed capillary tube system.
- Cassette® refrigeration is bottom-mounted and removable from the front for ease of maintenance. Refrigeration may be exchanged or upgraded without mechanic. Designed to hold 33°F to 38°F (0.5°C to 3.3°C).
- Priority, directed air flow provides optimum cooling and energy efficiency within cabinet and exclusively at front of unit for optimized heat exchange ventilation.
- Finless, Free&Clear™ Condenser Coil maximizes air-flow over the compressor, reduces energy consumption and is non-clogging.
- Automatic, stainless steel condensate control system.
- Quality, self-lubricating and sealed motors with streamlined air-flow provide quieter yet robust refrigeration.

Cabinet:

- Exterior – durable textured black.
- Interior – NSF approved black aluminum liner with stainless steel floor.
- Ergonomic raised interior floor.
- Space Saving Design – air ventilation exclusively from the front of unit.
- Insulation – cabinet is foamed-in-place with eco-conscious, polyurethane insulation.
- Heavy duty thread-in leveler legs.

Doors:

- Self-Closing Swing Door features hold-open position and spring-back protection, reversible on-location.
- Magnetic gaskets are single piece bead-mount construction easily removable for cleaning.
- Heat Reflecting full door HABCO Insulated Safety Glass with black extruded frame.
- Integrated, injection molded pocket handle(s).

Lighting:

- Energy Efficient Full LED Array Lighting System for crisp illuminated display of product.

Storage:

- Six (6) black coated shelves 26 1/4"W x 22"D (667mm x 559mm), are NSF approved.
- Heavy duty aluminum shelving pilasters will not peel or chip adjustment of 1/2" (13mm) increments.
- NSF-7 compliant for storage or display of pre-packaged aseptic product.

Electrical:

- Factory power cord installed for connection to a sole-use (dedicated) 115V/60Hz/1-Phase, 15 Amp circuit.

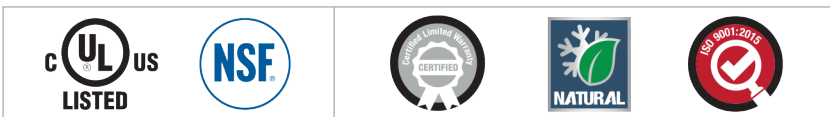
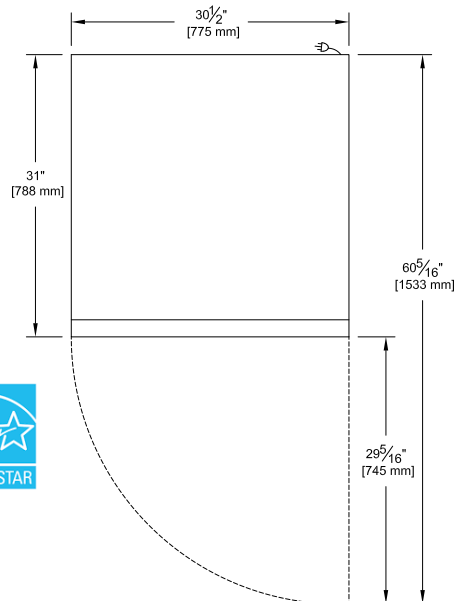
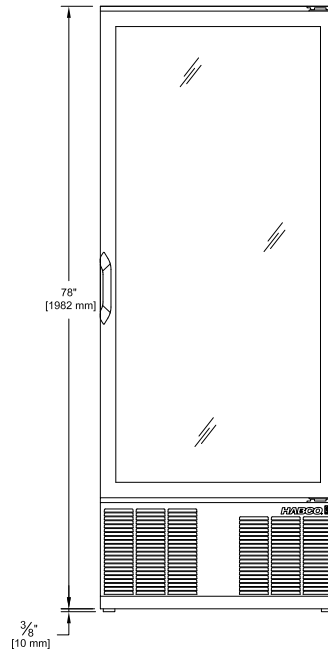

©2018 HABCO Manufacturing Inc. HABCO is a registered trade mark of HABCO Manufacturing Inc. in Canada, USA, U.K. and Germany. HABCO logo design, Built to Perform. Crafted to Last. and CASSETTE are registered trademarks of HABCO Manufacturing Inc. in Canada and U.S.A. Additional trade marks may be employed by HABCO and have been duly noted with respective registration mark or trade mark symbol. DOMESTIC AND INTERNATIONAL PATENTS.