



DCM-271BAK

CUBELET ICE MACHINE AND WATER DISPENSER



DCM-271BAK
08/13/25
Item # 13549K

W x D x H
16^{5/8}" x 24^{1/4}" x 31^{3/4}" *

*including 4" legs



Lower buttons for easy wheelchair access



Item #: _____

Project: _____

Qty: _____

AIA#: _____

Features

- ▶ LED touch buttons, upper and lower
- ▶ 10^{1/4}" cup clearance
- ▶ Environmentally friendly R290 hydrocarbon refrigerant
- ▶ Quieter operation
- ▶ ADA Compliant 

- Attractive modern design
- Easy to chew, Cubelet ice
- Up to 286 lbs. of ice production per 24 hours
- Built-in storage capacity of 0.3ft³/10 lbs.*
- Durable stainless steel drain pan grate
- Easy-cleaning removable spout
- 2-second flush cycle every hour
- Advanced CleanCycle24™ design 
- 6 ft. cord with a NEMA 5-15 plug

Warranty:

3 Year Parts & Labor on entire machine.
5 Year Parts on Compressor; air-cooled condenser coil.
Valid in United States, Canada, Puerto Rico and U.S. Territories. Contact factory for warranty in other countries.

*Rated in accordance with AHRI Standard 820(I-P). Capacity based on 100% of total volume x 30 lb/ft³ average density of ice.

Shipping: (LxWxH) 20.88" x 30.63" X 36.25" Volume: 13.42ft³

Condenser	Model	ICE PRODUCTION		WATER USAGE		ELECTRICAL				Heat Rejection BTU/hr.	Refrigerant Charge Amount	Net / Ship Weight (lbs.)
		Air / Water Temp Lbs. per 24 hours 70°/ 50°F	90°/ 70°F	Potable Gal. per 100 lbs. 90°/ 70°F	Condenser Gal. per 100 lbs. 90°/ 70°F	kWh Used per 100 lbs. 90°/ 70°F	Min. Circuit/Max. Fuse Size	Amperage	Voltage			
Air-Cooled	DCM-271BAK	286	211	12.0	N/A	5.3	15A	6.4A	115V/60/1	3,500	5.3 oz	136 / 154

Power cord included..

Cubelet Dimensions*

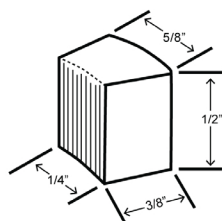

* approximate size in inches, image not to scale

Operating Limits

- Ambient Temp Range 45 - 100°F
- Water Temp Range 45 - 90°F
- Water Pressure 10 - 113 PSIG
- Voltage Range 108 - 127V
- If GFCI is required, a GFCI breaker MUST be used in lieu of GFCI receptacle

Service

- Allow 6" (15cm) clearance at rear and sides for proper air circulation and ease of maintenance and/or service should they be required. Allow 24" (61 cm) clearance at top to allow for removal of auger.

Not intended for outdoor use - avoid placement in direct sunlight.

Plumbing

- Icemaker Water Supply Line: Minimum 1/4" Nominal ID Copper Water Tubing or Equivalent
- Icemaker Drain Line: Minimum 3/4" Nominal ID Hard Pipe or Equivalent
- 3/4" MPT drain

Water Filter

Please refer to water filter specification sheet for recommendations.

Hoshizaki reserves the right to change specifications without notice.



DCM-271BAK

CUBELET ICE MACHINE AND WATER DISPENSER

DCM-271BAK
08/13/25
Item # 13549K

FRONT VIEW

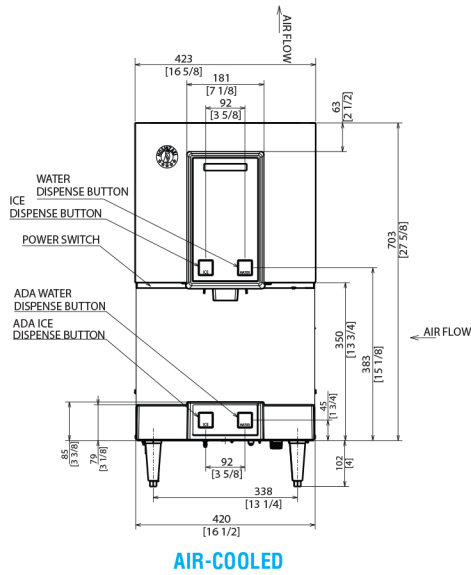

inch
[mm]

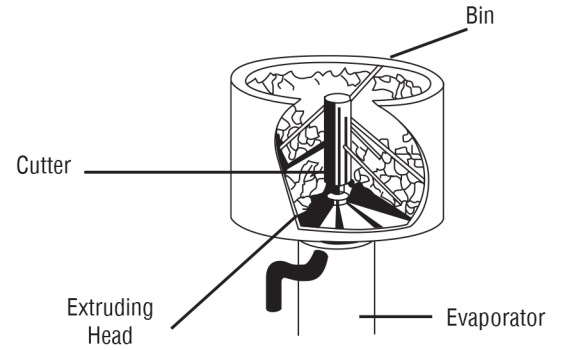

SIDE VIEW

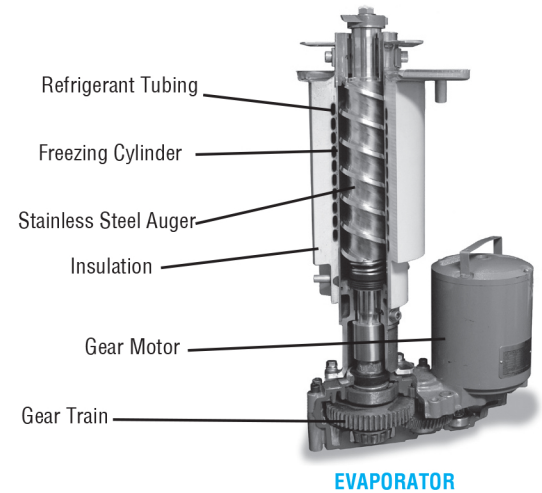
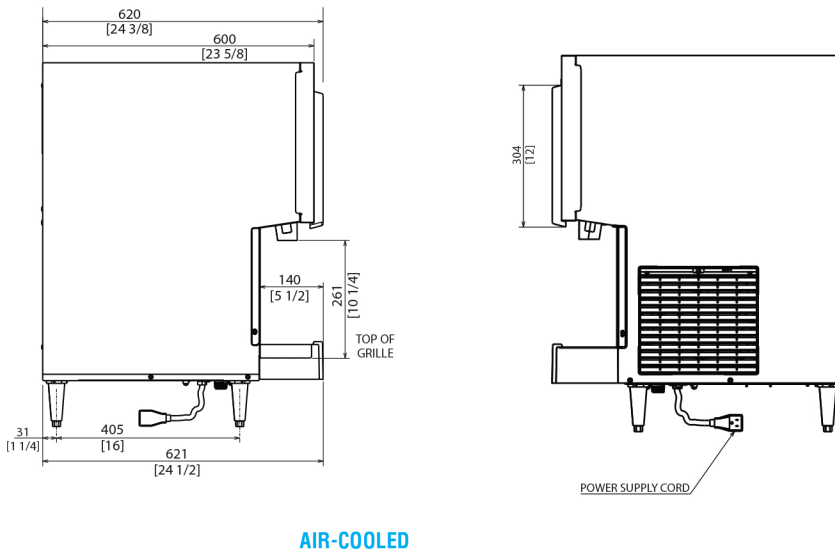

BOTTOM VIEW

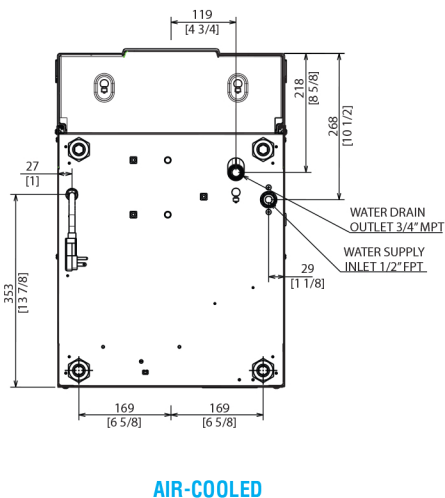

NOTE: DCM-271BAK is made to pair with SD-271 stand. Placing a DCM-271BAK on SD-270 stand will require a new drain hole to be cut.