



APEX REBELS MOTION

USER MANUAL

Ver. 1.04



! WARNING

- For safety reasons, please read the manual first before plugging in machine.
- Please keep this manual properly for convenient reference as needed.

About This Manual

Thank you for purchasing this product.

The manual describes how to install, set up, use and maintain the product. The main purpose of the manual is to instruct how to operate the product correctly and safely. Please follow all the safety and warning instructions in the manual to avoid personal injury and product damage.

'Site Maintenance Personnel' or Other Qualified Individuals

This product may only be maintained by a 'Site Maintenance Personnel' or Other Qualified Individuals.

Procedures not described in this manual or marked as 'to be carried out by site maintenance personnel or other qualified professionals' should not be carried out by personnel without the necessary skill or technological experience. Work carried out by unqualified persons may cause serious accidents, including electrocution.

When transferring the ownership of this product, be sure to provide this manual with the machine.

For further information about the game and repair (including consumables), please contact our company.

Sega Amusements International Limited All Rights Reserved.

Unauthorized reproduction of this document or any of its contents in any form is strictly forbidden.

Table of Contents

About This Manual

1. Safety Precautions	7
1.1 Placing Site	10
1.2 Precaution during Play	11
1.3 Transporting and Moving	12
1.4 Installing and Placing	13
2. Product Description	14
2.1 Product Specification	14
2.2 Cabinet Overview	15
2.3 Parts Name	16
2.3.1 Cabinet Component List	16
2.3.2 Cabinet LED List	17
2.4 Shipment List	18
2.5 Packing List	22
2.6 Install Direction	23
2.6.1 Installation of Cabinet	23
2.6.2 Installation of Transformer Wiring Switch	29
2.7 Air System Diagram	30
2.8 Compressor Maintenance Guide	31
3. Game Linking and Networking	35
4. Game Description and AO MENU	37
4.1 Game Description	37
4.1.1 Game Feature	37
4.1.2 Game Content	38
4.2 Game Flow	39
4.2.1 Front-End MENU	39
4.2.2 In-Game HUD	45
4.2.3 Back-End MENU	48

4.3	USB Drive Patching	51
4.3.1	USB Patching Steps	51
4.3.2	Cases of USB Patching	52
4.4	Operator MENU	54
4.4.1	Game Settings	56
4.4.2	Bookkeeping Settings	62
4.4.3	Credit Settings	64
4.4.4	Input Settings	68
4.4.5	Output Settings	83
4.4.6	Clock Settings	95
4.4.7	Network Settings	99
4.4.8	Language Settings	104
4.4.9	Reset All Settings	105
5.	Game Errors and Troubleshooting	106
5.1	I/O Connection Error	106
5.2	Motion Connection Error	107
5.3	Cabinet ID Error	108
6.	Maintenance and Service	109
6.1	Maintenance and Service	109
6.2	Parts Replacement	110
6.2.1	Replacement of Camera	110
6.2.2	Replacement of Coin Acceptor	111
6.2.3	Replacement of Air Compressor	112
6.2.4	Replacement of Boost Handle	113
6.2.5	Replacement of Boost Handle Switch	114
6.2.6	Replacement of Boost Handle Electromagnet	115
6.2.7	Replacement of Boost Handle Potentiometer	115
6.3	Air Compressor Maintenance Guide	116
6.3.1	Pre-use Preparation	116

6.3.2 Operation and Adjustment	117
6.4 Air Compressor Malfunction and Troubleshooting.....	118
6.4.1 Air Compressor Parts List	118
6.4.2 Air Compressor Troubleshooting	120
7. Assembly	122
7.1 Assembly Tree Diagram	122
7.2 General Assembly Diagram	123
7.3 Seat Assembly.....	124
7.3.1 Base Assembly.....	126
7.3.2 Motion Platform Assembly	127
7.3.3 Seat Assembly	128
7.3.4 Console Assembly	129
7.3.5 Steering Assembly	130
7.3.6 Pedal Assembly	131
7.3.7 Console Panel Assembly.....	132
7.3.8 Steering Wheel Assembly.....	133
7.3.9 Pneumatic Valve Assembly	134
7.3.10 Gearshift Assembly	135
7.3.11 Gas-Jet Assembly.....	137
7.3.12 Left Speaker Assembly	138
7.3.13 Right Speaker Assembly	139
7.3.14 Left Blower Assembly.....	140
7.3.15 Right Blower Assembly.....	141
7.3.16 Coin Door Assembly	142
7.3.17 Cash Box Assembly.....	143
7.3.18 Console Side Door Assembly.....	144
7.3.19 Service Panel Assembly	145
7.3.20 Rear End Assembly	146
7.4 65" Frame Assembly.....	148
7.4.1 Wooden Frame Assembly	150
7.4.2 Air Compressor Assembly	151
7.4.3 Main Unit Assembly	152



7.4.4 Power Switch Assembly	153
7.4.5 Transformer Assembly	154
7.4.6 Air Compressor Door Assembly	155
7.4.7 PC Door Assembly	156
7.4.8 Fan Assembly.....	157
7.4.9 Intake Fan Assembly	158
7.4.10 LCD Door Assembly	159
7.4.11 Camera Assembly.....	160
7.4.12 Filter Assembly	161
7.4.13 Sink Assembly.....	162
7.4.14 65" LCD Assembly	163
7.5 LCD Panel Assembly.....	164
8. Printing Pattern.....	165
8.1 Printing Pattern of Cabinet.....	165
9. Wiring Diagram	166
10. Spares and Service Contact Information	173

BEFORE USING THE PRODUCT, BE SURE TO READ THE FOLLOWING:



TO MAINTAIN SAFETY:

To ensure the safe operation of this product, be sure to read the following before usage: The following instructions are intended for the users, operators and the personnel in charge of the operation of the product. After carefully reading and sufficiently understanding the warning displays and cautions, handle the product appropriately. Be sure to keep this manual close to the product or in a convenient place for future reference.

Herein, explanations which require special attention are enclosed with dual lines. Depending on the potentially hazardous degrees, the terms of "DANGER", "WARNING", "CAUTION", etc. are used. Be sure to understand the contents of the displays before reading the text.

 DANGER	Indicates that mishandling the product by disregarding this pictograph will cause severe injury or death
 WARNING	Indicates that mishandling the product by disregarding this warning will cause a potentially hazardous situation which can result in death or serious injury
 CAUTION	Indicates that mishandling the product by disregarding this caution will cause a slight hazardous situation which can result in personal injury and/or material damage

For the safe usage of the product, the following pictographs are used:

	Indicates "HANDLE WITH CARE". In order to protect the human body and equipment, this display is attached to places where the instruction manual should be referred to
	Indicates a "protective earth terminal." Before operating the equipment, be sure to connect it to the ground (this step may be omitted for products in which a power cable with earth is used)

- **PERFORM WORK IN ACCORDANCE WITH THE INSTRUCTIONS HEREIN STATED**
Instructions for work are explained by paying attention to the aspect of accident prevention. Failing to perform work as per the instructions can cause accidents. In the case where only those who have technical expertise should perform the work to avoid hazardous situation, the instructions herein state that the site maintenance personnel should perform such work
- **BE SURE TO TURN OFF THE POWER BEFORE WORKING ON THE MACHINE**
To prevent an electric shock, be sure to turn off the power and unplug the power cable before carrying out any work that requires direct contact with the interior of the product. If the work is to be performed in the power-on status, the instruction manual herein always states to that effect
- **BE SURE TO GROUND THE EARTH TERMINAL (THIS IS NOT REQUIRED IN THE CASE WHERE A POWER CABLE WITH EARTH IS USED)**
This product is equipped with the earth terminal. When installing the product, connect the earth terminal to the "accurately grounded indoor earth terminal" by using an earth wire. Unless the product is grounded appropriately, the user can be subject to an electric shock. After performing repair, etc. for the control equipment, ensure that the earth wire is firmly connected to the control equipment
- **ENSURE THAT THE POWER SUPPLY USED IS EQUIPPED WITH AN EARTH LEAKAGE BREAKER**
Using a power supply which is not equipped with the earth leakage breaker can cause a fire when earth leakage occurs
- **BE SURE TO USE FUSES WHICH MEET THE SPECIFIED RATING (ONLY FOR THE MACHINES WHICH USE FUSES)**
Using fuses exceeding the specified rating can cause a fire and an electric shock

- **SPECIFICATION CHANGES (REMOVAL OF EQUIPMENT, CONVERSIONS AND ADDITIONS) NOT DESIGNATED BY SEGA ARE NOT ALLOWED**

The parts of the product include warning labels for safety, covers for personal protection, etc. It is very hazardous to operate the product by removing parts and/or modifying the circuits. Should doors, lids and protective parts be damaged or lost, refrain from operating the product, and contact where the product was purchased from or the office herein stated.

SEGA shall not be held responsible for any accidents or compensation for damage to a third party resulting from the specifications not designated by SEGA

- **ENSURE THAT THE PRODUCT MEETS THE REQUIREMENTS OF APPROPRIATE ELECTRICAL SPECIFICATIONS**

Before installing the product, check for electrical specifications. SEGA products have a nameplate on which the electrical specifications are described. Ensure that the product is compatible with the power supply voltage and frequency requirements of the location. Using any electrical specifications different from the designated specifications can cause a fire and an electric shock

- **INSTALL AND OPERATE THE PRODUCT IN PLACES WHERE APPROPRIATE LIGHTING IS AVAILABLE, ALLOWING WARNING LABELS TO BE CLEARLY READ**

To ensure safety for the customers, labels and printed instructions describing potentially hazardous situations are applied to places where accidents can be caused. Ensure that where the product is operated has sufficient lighting allowing the warnings to be read. If any label is peeled off, apply it again immediately. Please place an order with where the product was purchased from or the office herein stated

- **WHEN HANDLING THE MONITOR, BE VERY CAREFUL (APPLIES ONLY TO PRODUCTS WITH MONITORS)**

Some of the monitor parts are subject to high tension voltage. Even after turning off the power, some portions are still subject to high tension voltage. Monitor repair and replacement should be performed only by those technical personnel who have knowledge of electricity and technical expertise

- **BE SURE TO ADJUST THE MONITOR PROPERLY (APPLIES ONLY TO PRODUCTS WITH MONITORS)**

Do not operate the product leaving on-screen flickering or blurring as it is. Using the product with the monitor not properly adjusted may cause dizziness or a headache to an operator, a player, or customer

- **WHEN TRANSPORTING OR RESELLING THIS PRODUCT, BE SURE TO ATTACH THIS MANUAL TO THE PRODUCT**

* *In the case where commercially available monitors and printers are used in this product, only the contents relating to this product are explained herein. Some commercially available equipment has functions and reactions not stated in this manual. Read this manual together with the specific instruction manual of such equipment*

* *Descriptions herein contained may be subject to improvement changes without notice*

* *The contents described herein are fully prepared with due care. However, should any question arise or errors be found, please contact SEGA*

INSPECTIONS IMMEDIATELY AFTER TRANSPORTING THE PRODUCT TO THE LOCATION

Normally, at the time of shipment, SEGA products are in a state allowing for usage immediately after transporting to the location. Nevertheless, an irregular situation may occur during transportation. Before turning on the power, check the following points to ensure that the product has been transported in a satisfactory status:

- Are there any dented portions or defects (cuts, etc.) on the external surfaces of the cabinet?
- Are casters and/or adjusters damaged?
- Do the power supply voltage and frequency requirements meet with those of the location?
- Are all wiring connectors correctly and securely connected? Unless connected in the correct way, connector connections can not be made accurately. Do not insert connectors forcibly.
- Do power cables have cuts and/or dents?
- Are all accessories available?
- Can all doors and lids be opened with the accessory keys? Can doors and lids be firmly closed?

INTRODUCTION

This manual is intended to provide detailed descriptions together with all necessary information covering the general operation of electronic assemblies, electromechanical, servicing control, spare parts, etc. for the product:

"APEX REBELS"

This manual is intended for the owners, personnel managers in charge of operation of this product. Operate the product after carefully reading and sufficiently understanding the instructions.

In the unlikely event that the product does not function correctly, **DO NOT** allow anyone other than a technician to touch the internal system. Turn off the power to the machine, making sure to unplug the electrical cord from the outlet, and contact the office listed below or the point-of-purchase for this product.

Use of this product is unlikely to cause physical injuries or damage to property. However, points that require special attention are indicated by bold text, the words "STOP, IMPORTANT or CAUTION" and the symbols below.



Indicates important information that, if ignored, may result in the mishandling of the product and cause faulty operation or damage to the product.



Indicates a warning or caution that, if ignored, may result in the mishandling of the product and cause faulty operation or damage to the product.

1.1 Placing Site



- **Ensure the building has a proper earth ground before connecting the game to the supply.**
- **This machine is designed for indoor use only. Never install the machine outdoors. Meanwhile, please avoid the following locations indoor:**
 - **Direct sunlight, water leakage, damp and high temperature places.**
 - **Near Flammable, volatile, or/and dangerous substance.**
 - **Slope, unstable places or locations subject to frequent vibration.**
 - **Near emergency exit, fire extinguisher or similar equipment.**
- **The rear part has the vent for heat emission from PC or screen. Don't place anything nearby to avoid game failure**
- **Provide a space of minimum 30cm between the rear of the machine and the wall for good ventilation and heat emission.**

1.2 Precautions during Play



- **In order to avoid injury and accident during play, the following people shall not play the game:**
 - **People who are injured or less mobile.**
 - **Person with poor health condition, such as hypertension or heart disease.**
 - **Person wearing high-heeled or slippery shoes.**
 - **Person who's feet cannot touch the stepping base.**
 - **Pregnant woman, drunk people.**

- **When a player feels uncomfortable during play, remind the person to have a break, or stop playing.**

- **Make sure the player reads the Warning labels and other indications, and plays in accordance with the instructions to avoid accidents such as electric shock and short circuit.**

- **Bystander shall not operate any button when the player is playing the game to avoid unnecessary trouble.**

1.3 Transporting and Moving



Transporting

- **When transporting the machine on a vehicle, please fix the casters and fully wind down the adjusters. Failure to do this may cause damage to the machine.**
- **When carrying the machine with a forklift, be sure to insert the fork to fork position and lift stably or it may cause accident and damage to the machine.**
- **The glass and LCD screen are fragile. Avoid violent vibration or shock when transporting.**

Moving

- **Before moving the machine, unplug the power plug to prevent accident.**
- **Pay attention to the obstructions and uneven surface when moving the machine to prevent accidents and damage to the machine.**
- **Fully retract all leg adjusters before moving to prevent accidents.**
- **Make sure to use at least two people to conduct the above work to avoid accident and injury.**
- **Pay attention to the moving direction, see fig.**



1.4 Installing and Placing

Pay attention to the following when placing the machine.



- Place the machine on the flat and slip resistant area.
- Use the adjusters to fix the machine (See Diagram A).
 - (1) Loosen the nuts for the adjusters(clockwise), tighten the bolts with a wrench (clockwise).
 - (2) Tighten the nut firmly (counter-clockwise) and fix it well.

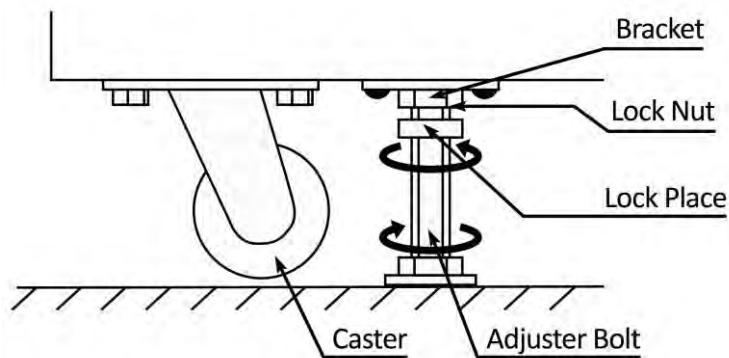

Diagram A

- Provide a space of minimum 30cm between the rear of the machine and the wall for good ventilation and heat emission (see Diagram B and C).

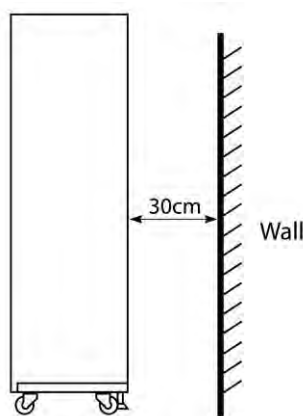

Diagram B

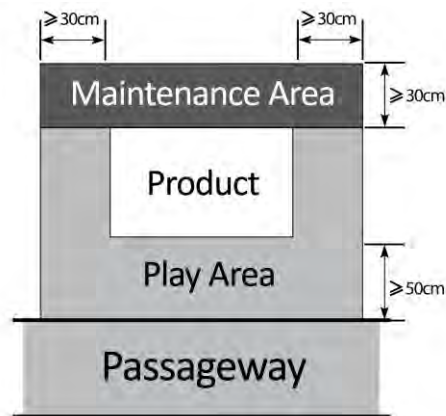

Diagram C

2. Product Description

2.1 Product Specification

▪ Location	Indoor Only
▪ Dimension	1540(W) x 2780(D) x 2430(H)mm
▪ Rated Voltage, Frequency	240VAC 50Hz
	110VAC 60Hz
▪ Power Consumption	Main Cabinet = 1200W (Max) Compressor = 1700W (Max)
▪ Weight	502kgs
▪ Temperature Range	5~40 °C

*110V voltage can be set through the transformer and fuse. Please contact the distributor for details.

NOTE: The contents herein described are subject to change without notice.

Transformer Wiring Configuration Details - Please refer to 2.6.2 for details.

► Front View

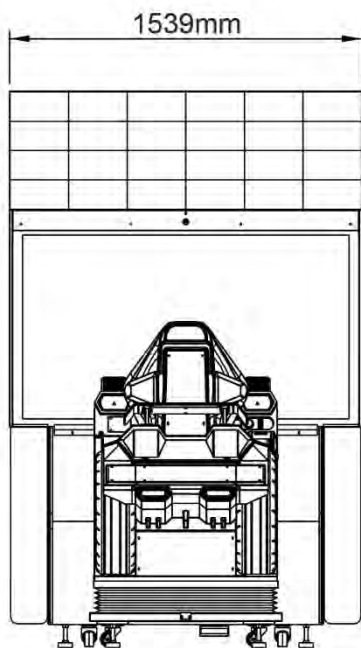

► Side View

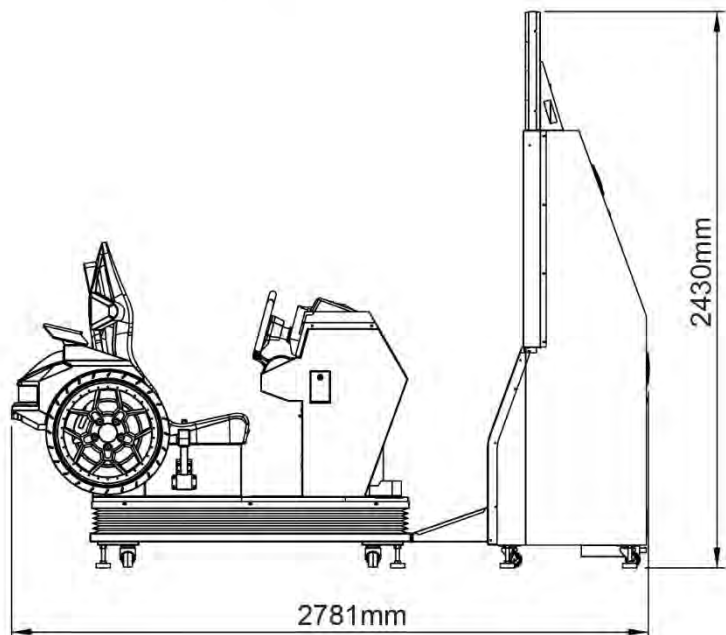

2.2 Cabinet Overview

► Side View

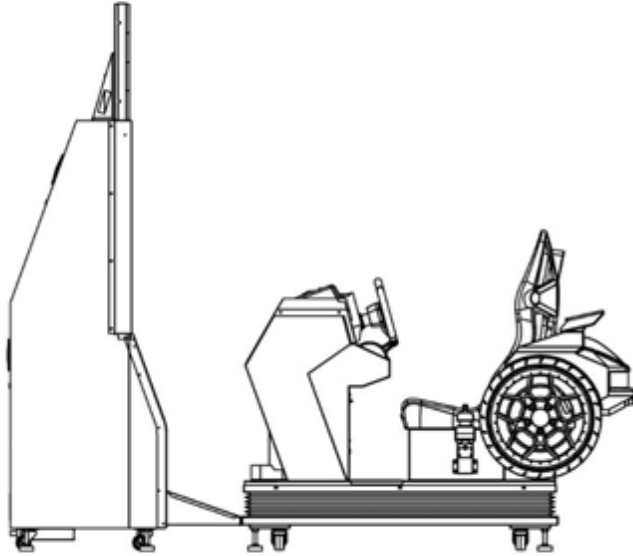

► Rear View

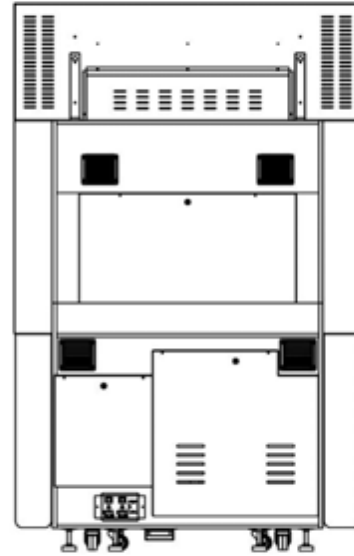

► Top View

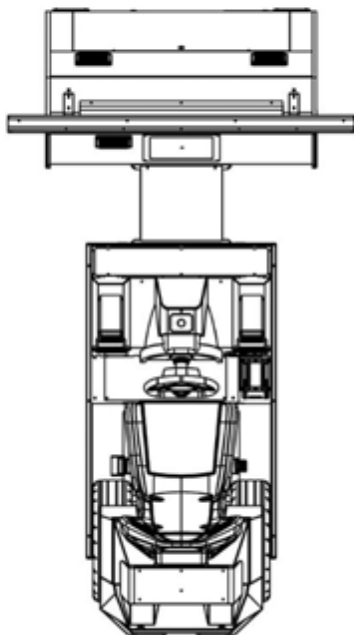

► Bottom View

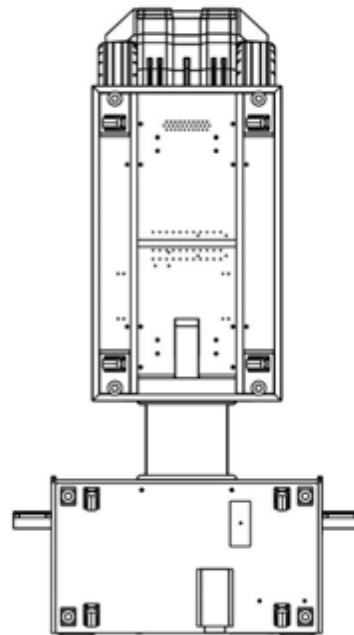

2.3 Parts Name

2.3.1 – Cabinet Component List

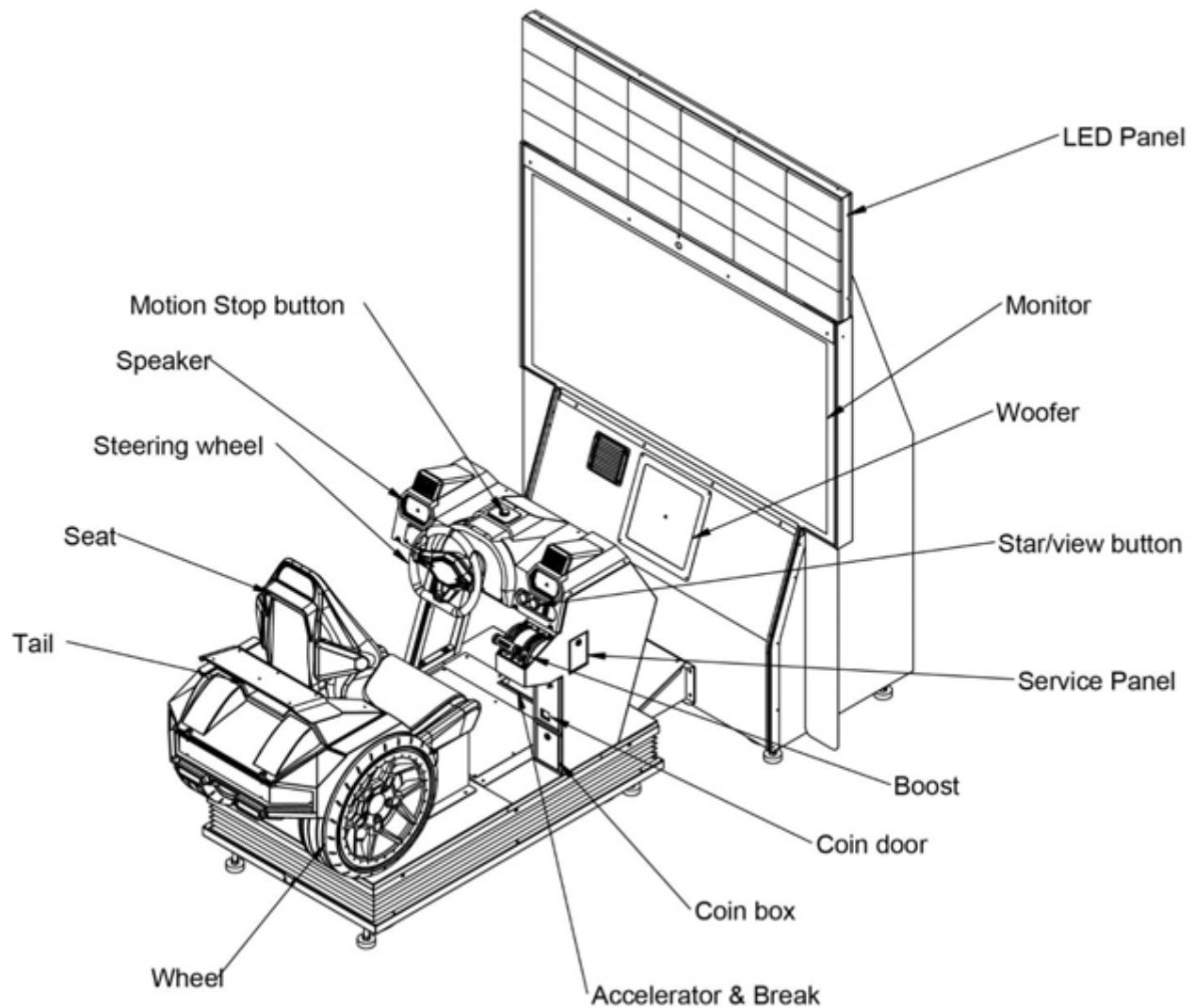

2.3.2 – Cabinet LED List

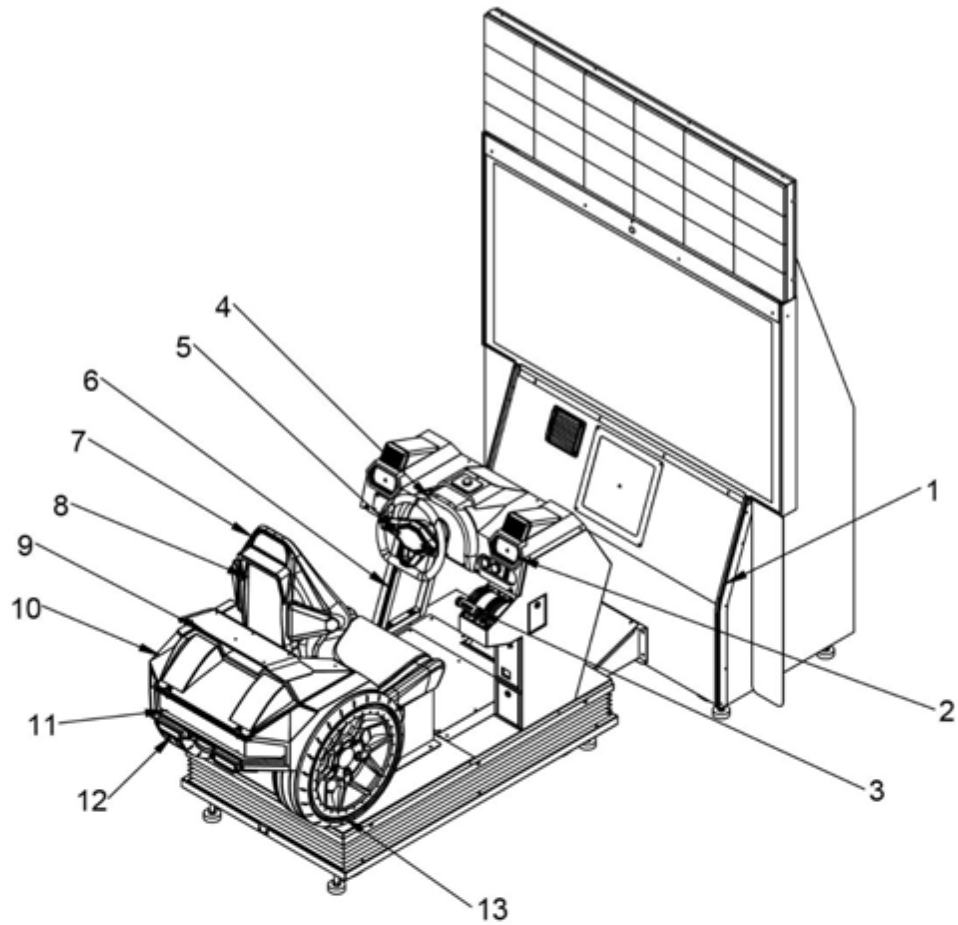

No.	illustrate	Part No.	Name	Specification	QTY
1	Monitor	ATC-8001H01	LED	SK6812 chip soft L=830mm	2
2	Speaker	ATC-8002H01	LED	DC12V RGB 5mm L=400mm	2
3	Boost	ATC-0110H01	LED	RGB-12V-4	2
4	Instrument panel	ATC-8002H02	LED	DC12V RGB L=100+150+100mm	1
5	Steering wheel	ATC-8002H12	LED	DC12V RGB 8mm L=150mm	1
6	Console	ATC-8001H04	LED	SK6812 chip soft L=500mm	1
7	Seat	ATC-8002H08	LED	DC12V RGB L=350mm	2
		ATC-8002H09	LED	DC12V RGB L=500mm	2
		ATC-8002H10	LED	DC12V RGB L=550mm	1
8	Seat Back	ATC-8002H11	LED	DC12V RGB L=250mm	2
9	Tail	ATC-8002H03	LED	DC12V RGB 8mm L=350mm	1
10	Rear	ATC-8002H05	LED	DC12V RGB L=1200mm	1
		ATC-8002H06	LED	DC12V RGB L=450mm	2
		ATC-8002H07	LED	DC12V RGB L=150mm	2
11	Break	ATC-0120H02	LED	SK6812 chip soft L=320mm	6
12	Exhaust	ATC-8002H04	LED	DC12V RGB L=100mm	2
13	Wheel	ATC-0120H01	LED	SK6812 silica gel L=1380mm	2

2.4 Shipment List

- Packing Carton 1/4 (Seat Assembly): 1490(W)*910(D)*1570(H)mm; 232.50KGS

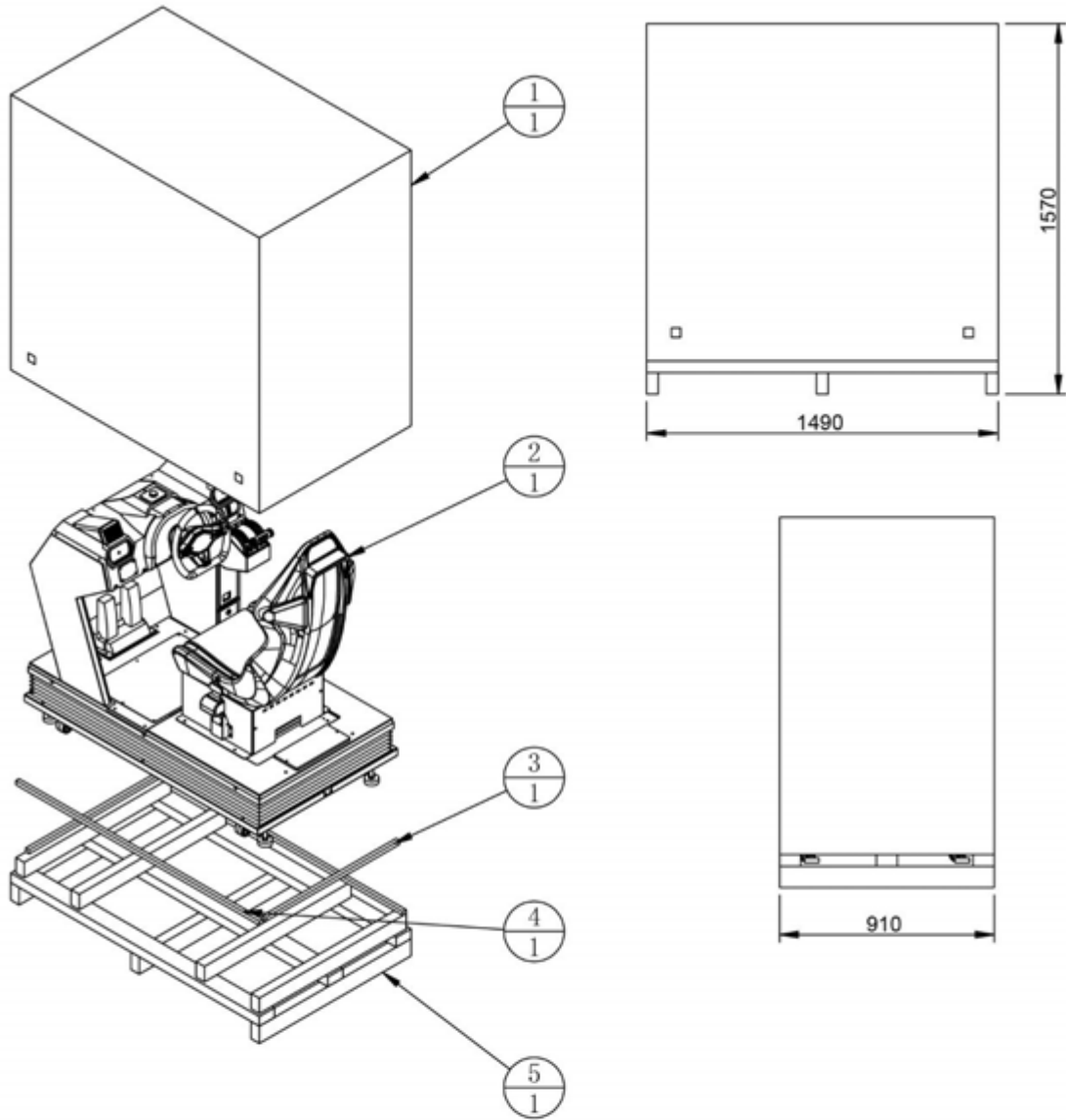

5	ATC-9901E01	Seat Floor Rack	Wood	1	
4	ATC-9901E03	Limit strip one	Wood	1	
3	ATC-9901E04	Limit strip two	Wood	1	
2	ATC-0100000	Seat assembly		1	
1	ATC-9901E02	Seat half-page box	2C 850g T-7	1	
No.	Drawing No.	Name	Specification	Qty	Other

▪ Packing Carton 2/4 (Monitor Assembly): 1580(W)*750(D)*2050(H)mm; 270KGS

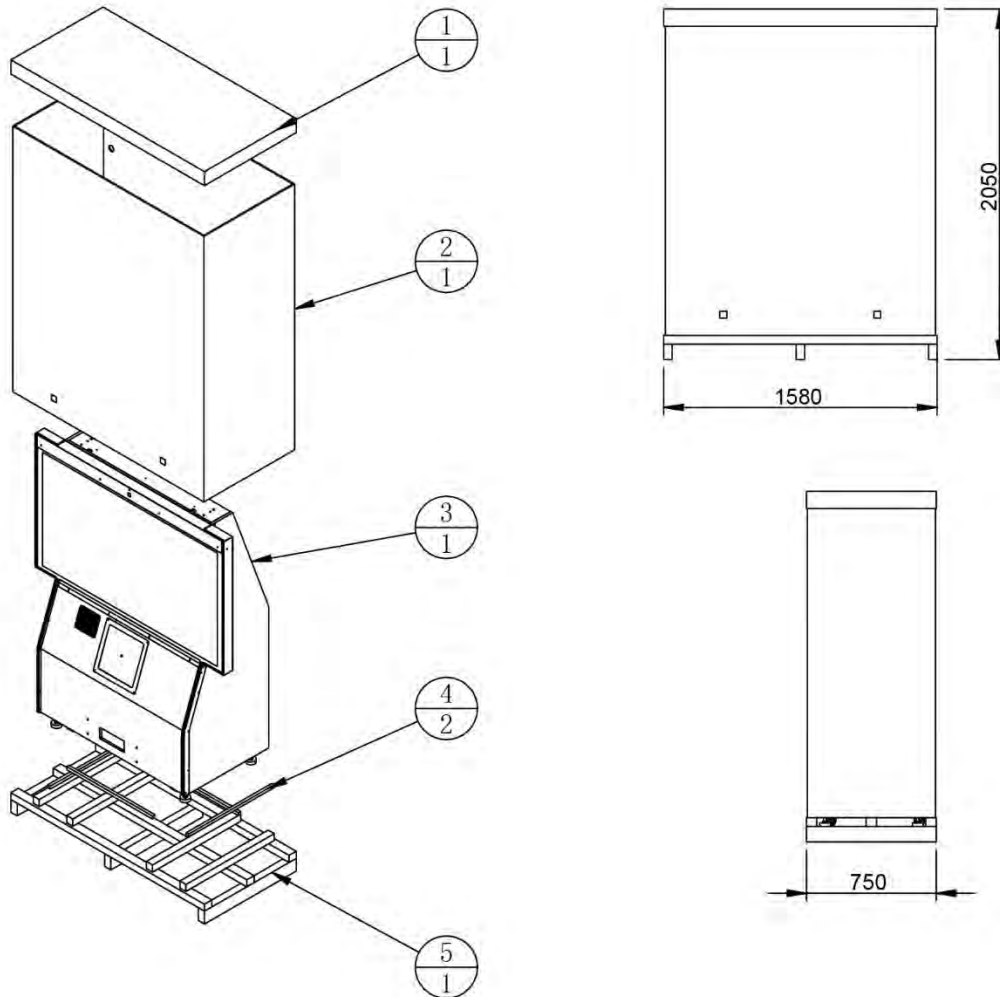

5	ATC-9902E01	LCD frame floor Rack	Wood	1	
4	ATC-9902E04	Limit strip three	Wood	2	
3	ATC-0200000	LCD assembly		1	
2	ATC-9902E02	Liquid crystal frame fence	2C 850g T-7	1	
1	ATC-9902E03	Liquid crystal frame canopy	2C 850g T-7	1	
No.	Drawing No.	Name	Specification	Qty	Other

- Packing Carton 3/4 (Rear Assembly): 860(W)*740(D)*800(H)mm; 32.50KGS

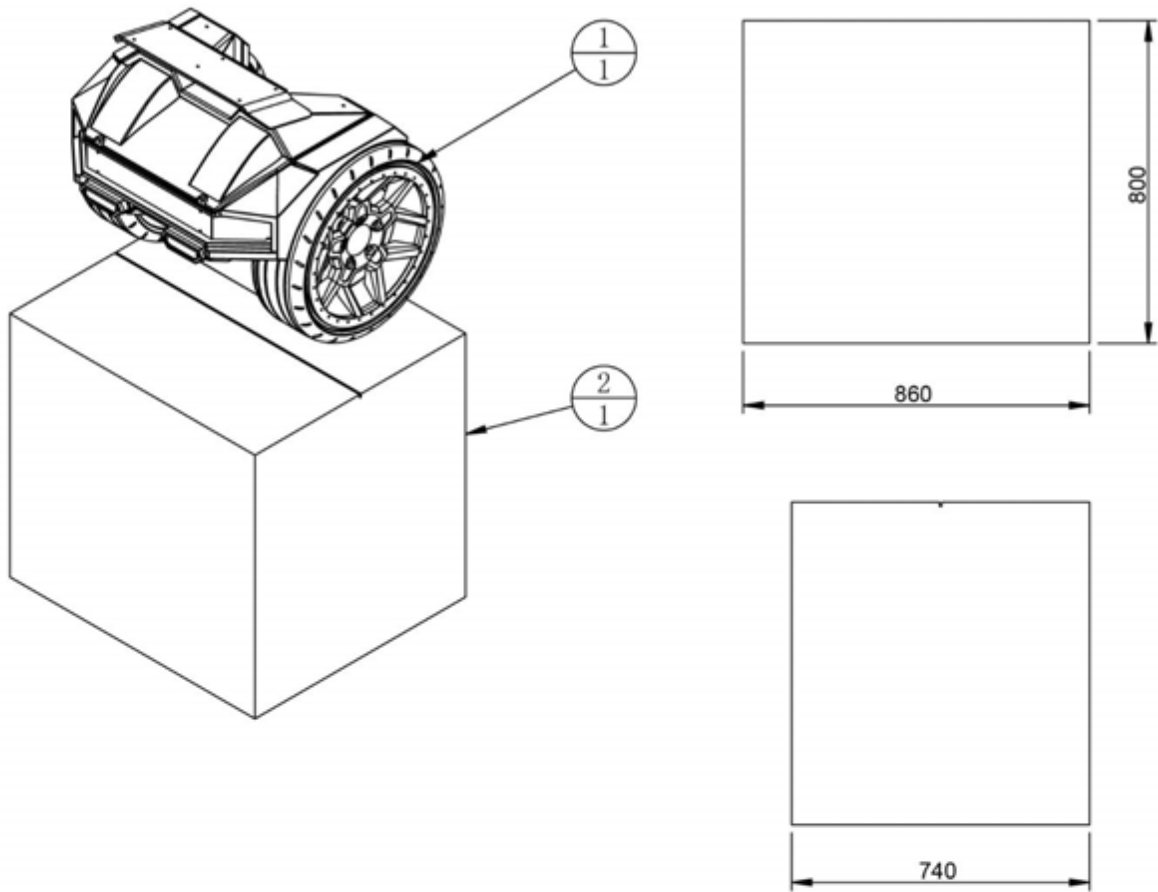

2	ATC-9903E01	Tail carton	2C 850g T-7	1	
1	ATC-0120000	Tail assembly		1	
No.	Drawing No.	Name	Specification	Qty	Other

- Packing Carton 4/4 (Light-Box Assembly): 1580(W)*570(D)*200(H)mm; 31KGS

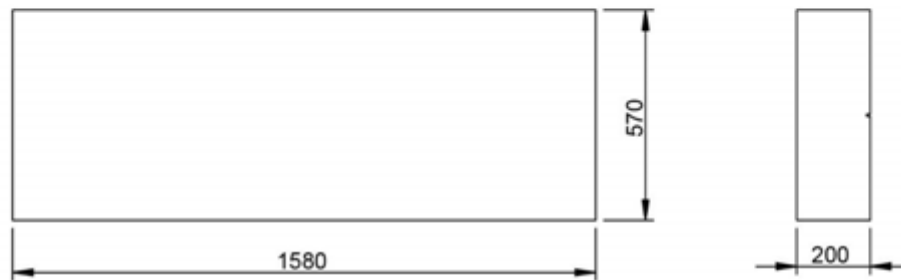
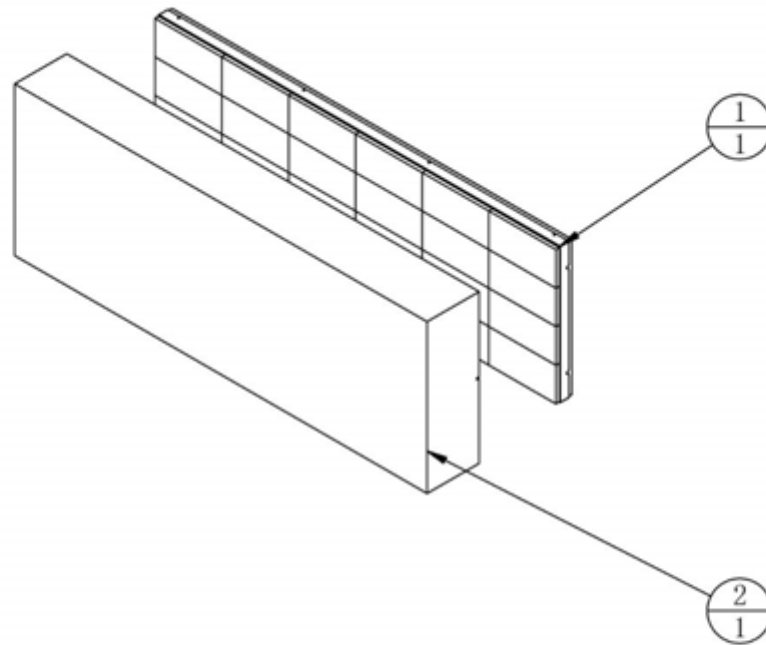

2	ATC-9904E01	Light box carton	2C 850g T-7	1	
1	ATC-0300000	LED Panel Assembly		1	
No.	Drawing No.	Name	Specification	Qty	Other

2.5 Packing List

Please check the following items after purchasing our product. If any part is missing or damaged, please contact our sales person.

No.	Description Name	Material / Specifications	Qtn.	Remarks
1	Network cables		1	
2	314 Fuse (spares)	F10A/6*30(220V)	2	TMW-0104H02
3	326 Fuse (spares)	F20A/6*30(110V)	2	TMW-0104H06
4	Key		6	
5	Sink		1	ATC-0215000
6	Side Flag Boards		2	ATC-0200A09
7	Power Cable		2	
8	Spacer Column		2	ATC-0000A03
9	Digital Sticker (back of the seat)		4	ATC-P0006
10	Lower Flag		2	
11	Outer Hexagon Screw	M8*35	6	
12	Outer Hexagon Screw	M8*20	4	
13	Outer Hexagon Screw	M6*35	4	
14	Hexagon Flat Head Screw	M4*12	8	
15	Owner's Manual		1	

2.6 Install Direction

2.6.1 – Installation of Cabinet

Step 1. Remove the compressor door/PC door & monitor door from the monitor cabinet.

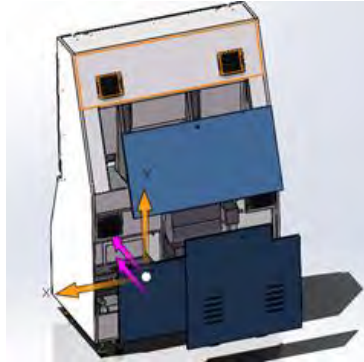

Step 2. Assemble the water storage box onto the monitor frame (4 nuts).

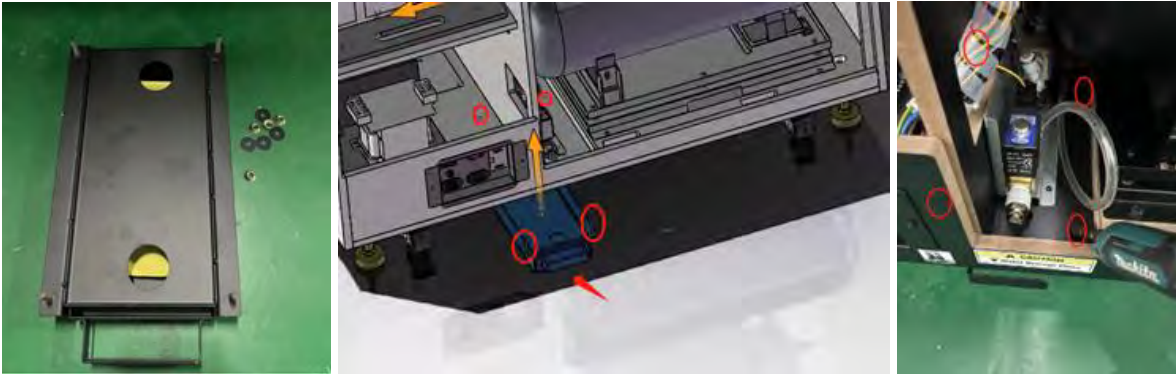

Step 3. Remove the LED PANEL ASSY back cover & bracket.

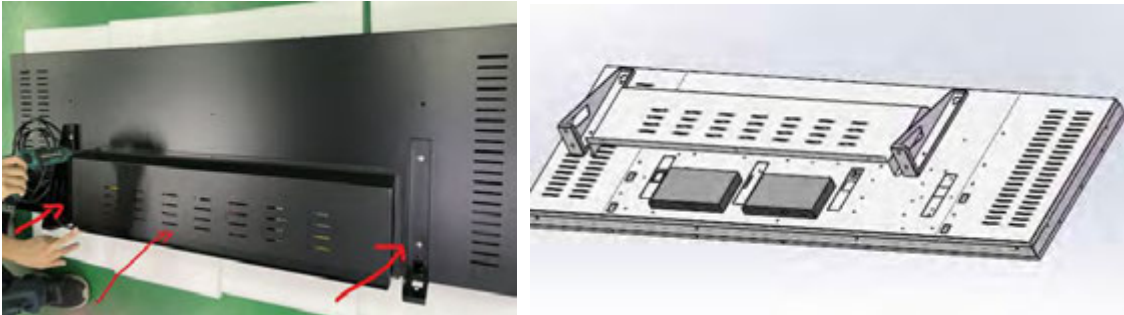

Step 4. Fix the bracket to the top of monitor frame (4 screws).

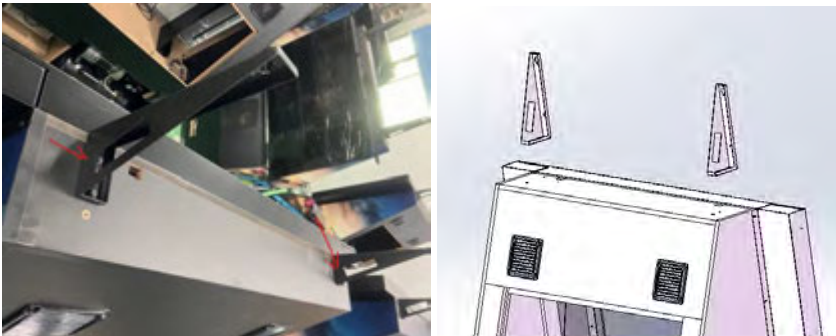

Step 5. Insert two screws into the top holes on the LCD panel (2-3 turns) and hang the LED PANEL onto the bracket. Insert and tighten the bottom two screws through the bracket and into the LED panel and tighten all 4 screws. **(NOTE: Minimum of 3 people to complete this step)**

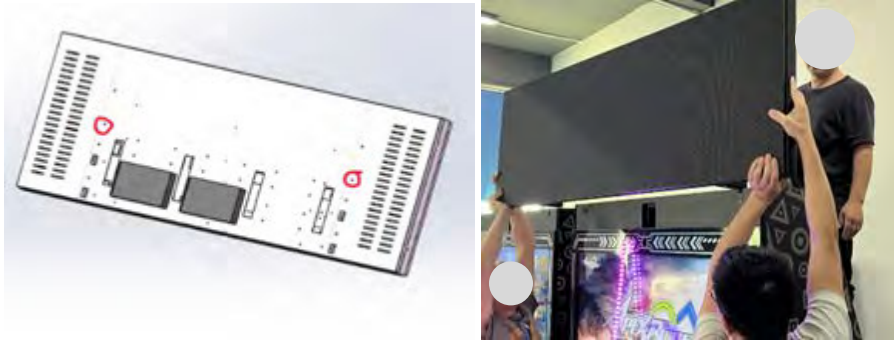

Step 6. Connect the power cable from the LED panel to the receptacle inside the back of the game.



Step 7. Connect the HDMI cable between the PC (Lower left rear door of the cabinet and the LED panel).

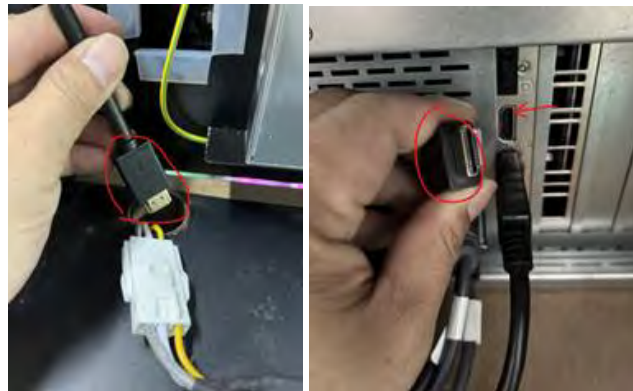

Step 8. Fix the back cover to the LED PANEL ASSY.



Step 9. Remove the back cover of the seat.



Step 10. Stick corresponding numbers on the back cover according to the machine number.



Step 11. Fix the back cover to the seat.

Step 12. Remove the cover of the rear ASSY.

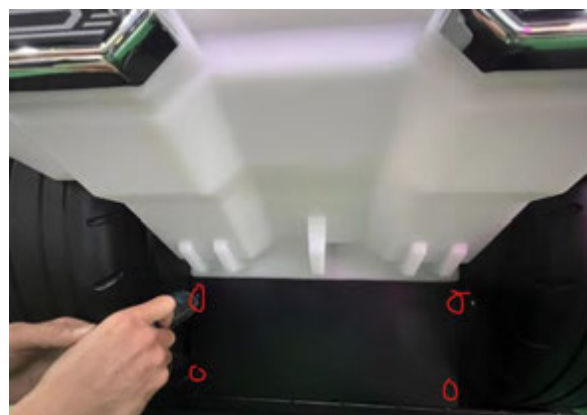

Step 13. Fix the rear ASSY to the seat ASSY and connect the wiring harnesses.



Step 14. Fix the cover to the rear ASSY.

Step 15. Fix the connection frame to the seat frame with spacing columns and screws.

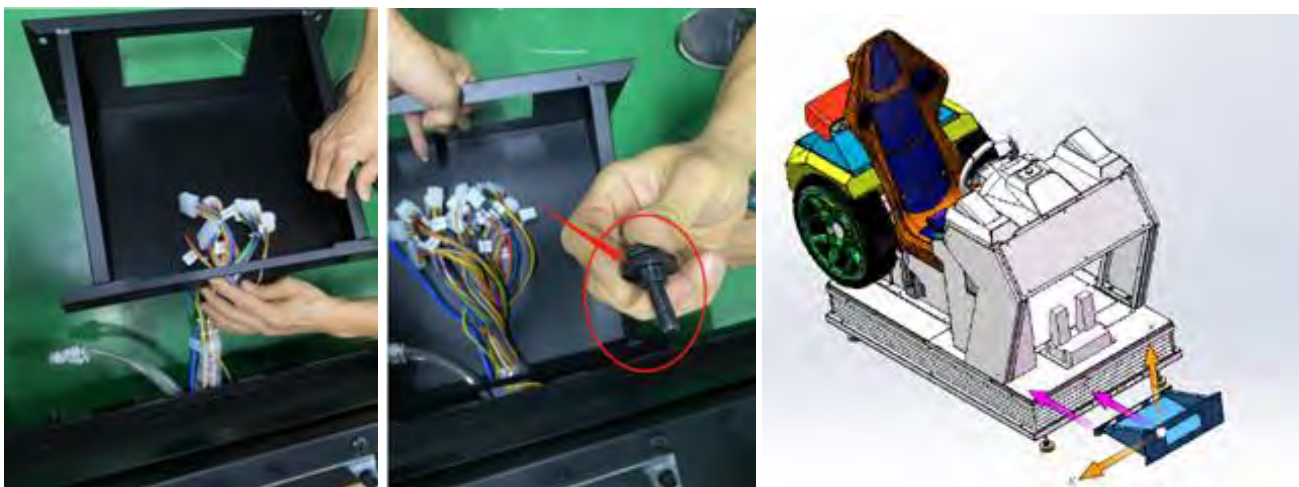

Step 16. Fix the connection frame to the monitor frame (4 screws).

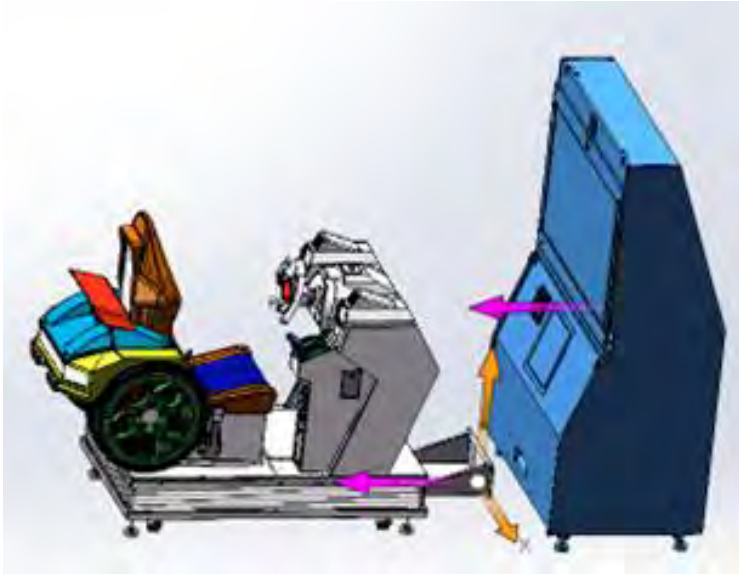
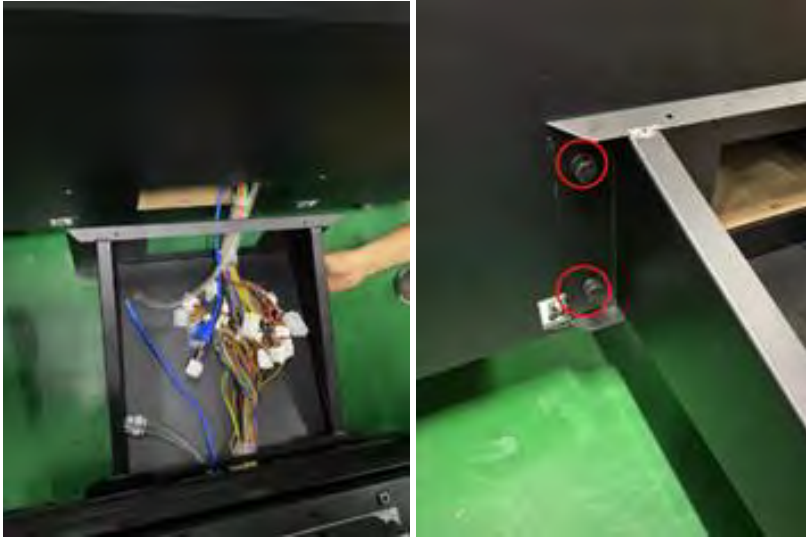

Step 17. Connect all wires and air pipes.

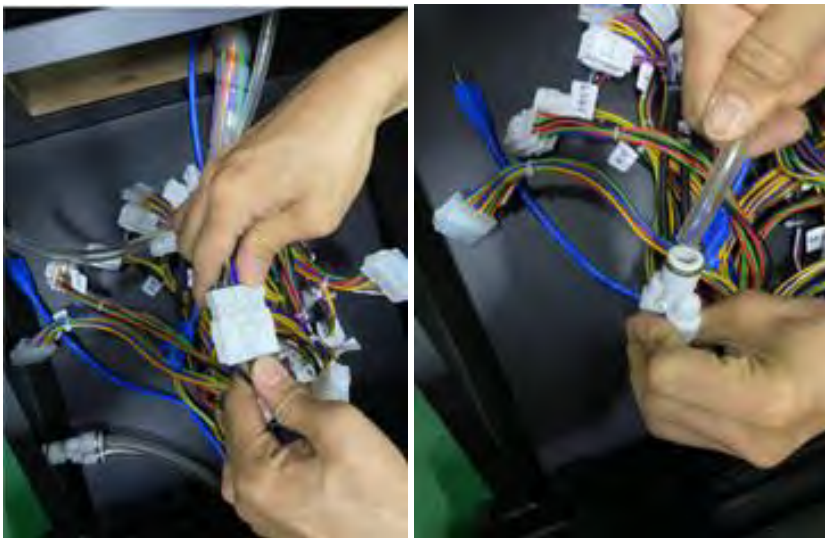

Step 18. Fix the cover plate on the connection frame.

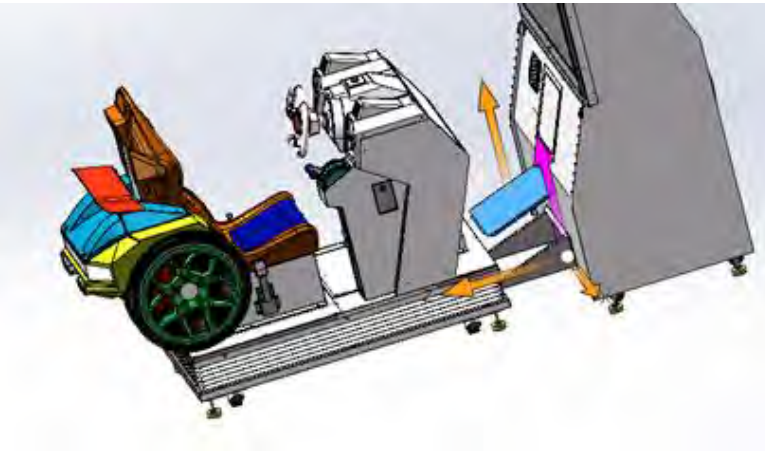

Step 19. Fix the flag to the monitor frame.



Step 20. Close all the doors.
The cabinet assembly is completed.

2.6.2 – Installation of Transformer Wiring Switch

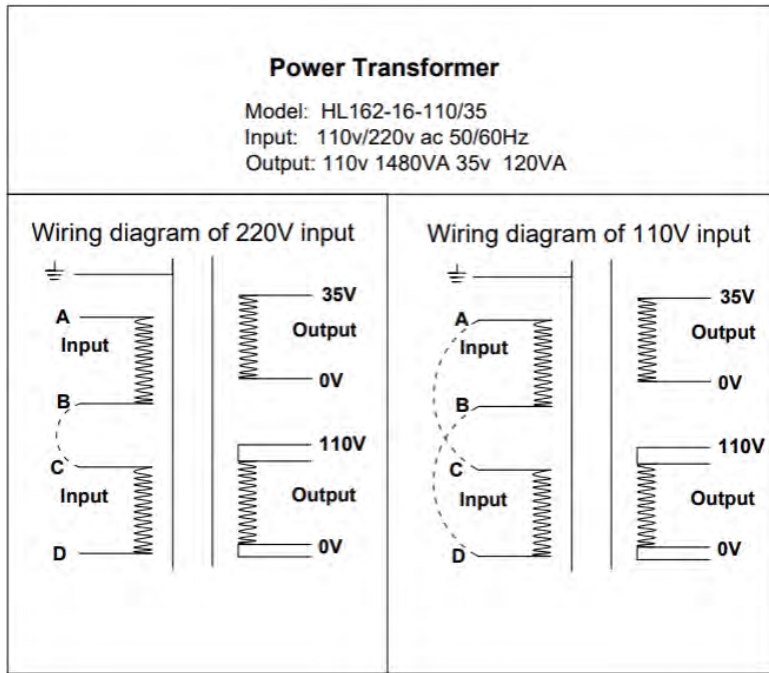

2.7 Air System Diagram

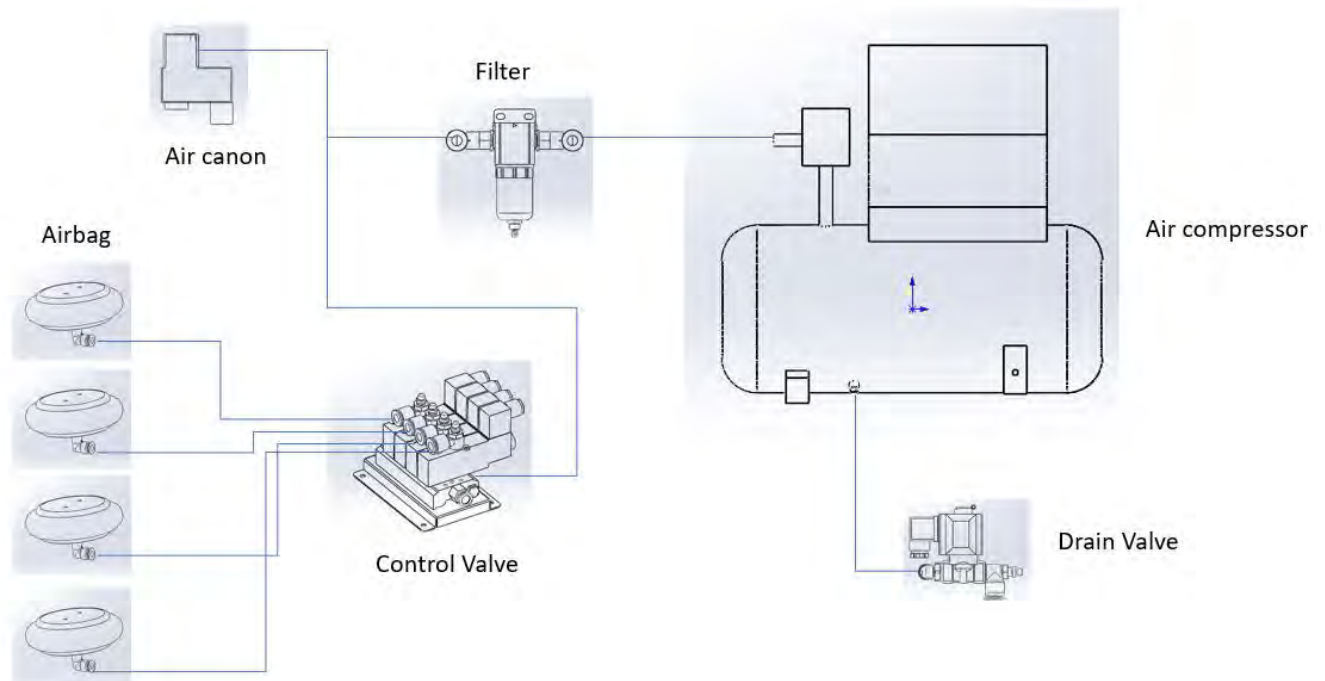

2.8 Compressor Maintenance Guide

As with all air-driven motion games, the compressor and general air circuit requires semi-regular maintenance. This guide is to be used to ensure your game stays in A1 condition:

Air Connections:

Check the inlet and outlet pipes to ensure they are all secure and show no signs of damage or wear.

Position	Name
1	Outlet valve
2	Gas Source unit (Input and output connections)
3	Drain valve input
4	Input and Output control valves

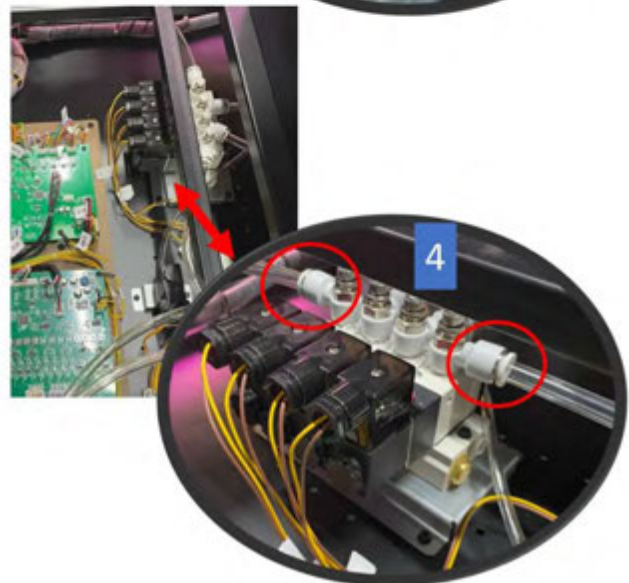

It is also prudent to check that there is no water in the output tubes between the compressor, gas source and control valves.

NOTE: Only the drain valve should contain water residue.

Drain Valve:

Drain Valve:

Check proper operation of the drain valve.

- Remove the 2x 13mm hex fixings from the compressor plate and pull the compressor out and turn it 90 degrees to access the back.
- Check the pipe is connected securely into the drain plug at the base of the compressor and at the drain valve to the left of the compressor.
- The drain valve should have a 12v supply and will be hot under normal operation.
- When the power is turned off to the game, the drain valve should open, and air should expel from the valve into the water tray below.
- When the game is turned ON, this valve will also open for Approx. 5 seconds to clear any residue from the tank.
- There is an adjustment to the valve that can attenuate the output pressure of the air from the compressor tank to the output tray.
- To increase the output pressure, loosen the locking nut, and turn the screw adjustment counter-clockwise until the desired pressure is set. Now close the locking nut so it is secure.

NOTE:

Only the drain valve should contain water residue.

If the compressor expels a lot of water into the tray, or the tube seems to have more corroded water than normal, you may have to remove the compressor and drain the tank manually by removing the plug in the base and tipping the compressor on its side.

Warning: Before removing the compressor, ALWAYS ensure the tank is empty of air by checking the regulated pressure gauge.

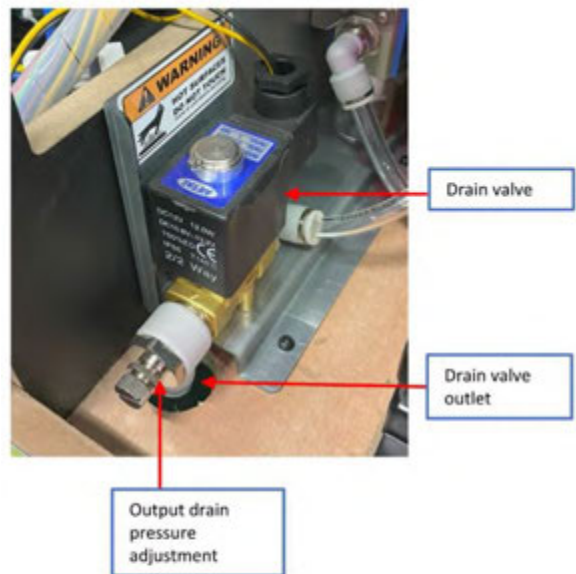
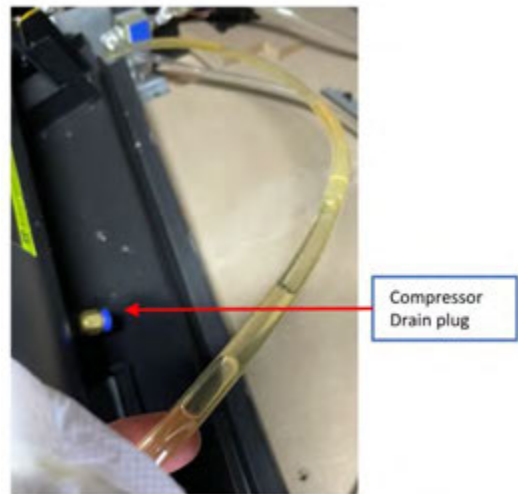

Compressor Pressure:

It is paramount to correct operation and safety that the regulated tank and output pressures are correct.

- Power on the game and the compressor tank should charge to the regulated pressure of Approx 700kPa (7 BAR)



WARNING: If it goes past this and into the red then turn game OFF immediately and seek advice from Sega.



Regulated pressure

- The output pressure can be attenuated but should be around 300kPa (3 BAR) and no more than 500kPa (5 BAR)
- Use the Red dial on top of the gauge to increase and decrease the pressure noting the +/- markings.



Output pressure dial

Output pressure

- Ensure the stop valve works correctly.
 - Perpendicular to the outlet and pipe = Closed
 - In line with outlet and pipe = Open (Normal operation).

To check this, turn the lever from the open position to closed and remove the outlet pipe from the coupling.

Now open the lever and check that air expels correctly from the compressor.



Output valve open/close lever.

Picture shows the valve in the open position.

Electrical Checks:

Compressors generate a lot of current which translates to heat, plus the motor will get hot, so regular checks of electrical connections and mechanical integrity is of utmost importance to safety and prolonged operation.

- Check that the ON/OFF pressure switch operates correctly.
Pull up for **ON** / Push down for **OFF**

Power OFF the compressor:

- Remove the screw in the top and lift off the lid to access the internal area of the pressure switch.
- Check that all terminals are tight using a crosshead screwdriver.

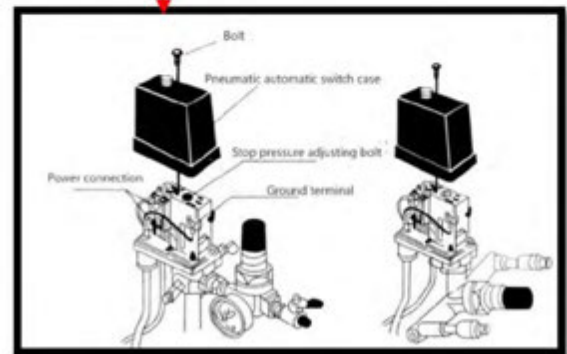
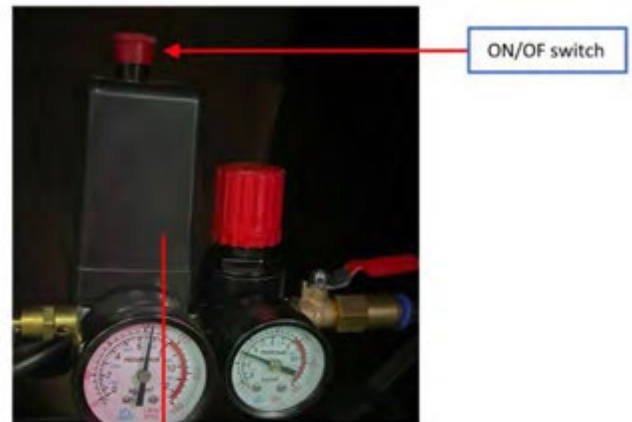

Final checks:

- Check the compressor motor casing for any cracks or wear
- Check there is no abnormal vibrations when the compressor is running
- Check that all connections between the motor and compressor housing are secure and not loose.
- Check all other bolts around the compressor.

If you have any concerns on the content of this guide, or have any other questions, please contact your local distributor for advice.

3. Linking and Networking

In the below figure, it shows how 4 cabinets should be linked up with the router by cables separately.

Note 1: Please make sure all games are in the same version in order to be linked with.

Note 2: 2-player configuration does not require a router and the PC's should be directly connected.



In the router, the LAN ports are where cable(s) to PCS should be inserted; the WAN port is where the Internet cable should be inserted.

NOTE: A Router is required to handle the IP addresses and a switch will not work if the game is set to Auto.

- In the router/switch, the **LAN ports** are where cable(s) to PCS should be inserted;
- the **WAN port** is where the internet cable should be inserted;
- If using switch, all the cabinets need to set static IP in networking settings.

Networking

How To Set Static IP:



Open the **AO Test Menu** ----> **Network Settings** ----> **IP Mode**

Select **Manual**

Configured by Range 1, 2 and 3, then select [**Confirm IP**] to apply changes.

All the cabinets should have the same IP by Range 1, 2 and 3.

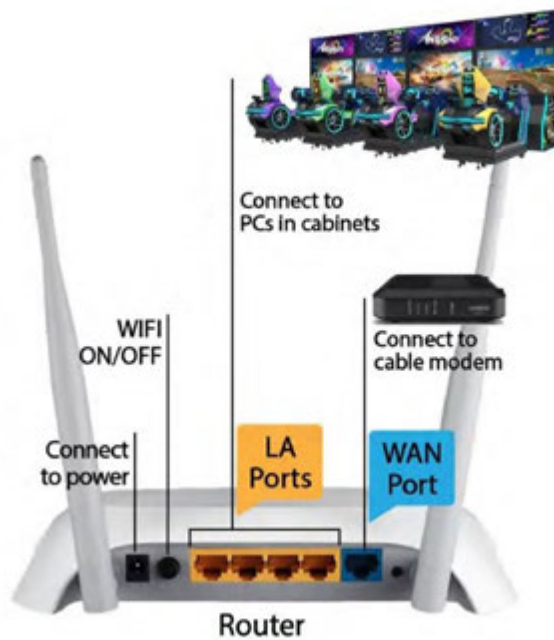

4. Game Description and AO MENU

4.1 Game Description

4.1.1 GAME FEATURE

- Up to 4 players linked play
- 5 vehicles to select from
- 2 Game Modes:
 - Campaign Race (Single-play)
 - Championship Mode (Multi-play)
- 3 Track Difficulties: Standard, Advanced and Expert
- Specially designed motion platform with air cannon system
- LED Matrix Display Billboard
- Full LED illuminated Cabinet
- Live Camera face detection of player (auto detected) during the game
- 65" monitor

4.1.2 GAME CONTENT

Tracks

There are total of 4 tracks in 3 difficulties: **Standard**, **Advanced** and **Expert**.

4 Tracks:



Vehicles

There are a total of 5 cars with different abilities.

5 Cars:





Game Modes

- **Campaign Race (Single-play)**
Player can have his own racing game without joining with other cabinets.
- **Championship Mode (Multi-play)**
Up to 4 players can be linked within the same location for the same race.

4.2 Game Flow

4.2.1 Front-End MENU

Scene 1: Insert Coin Page

Insert coin page will be appeared to ask player to insert coins and start the game.



Scene 2: Insert Coin Page

After insert coins, the game will start soon.



Scene 3: Warning Message

A warning screen will appear after game is started.

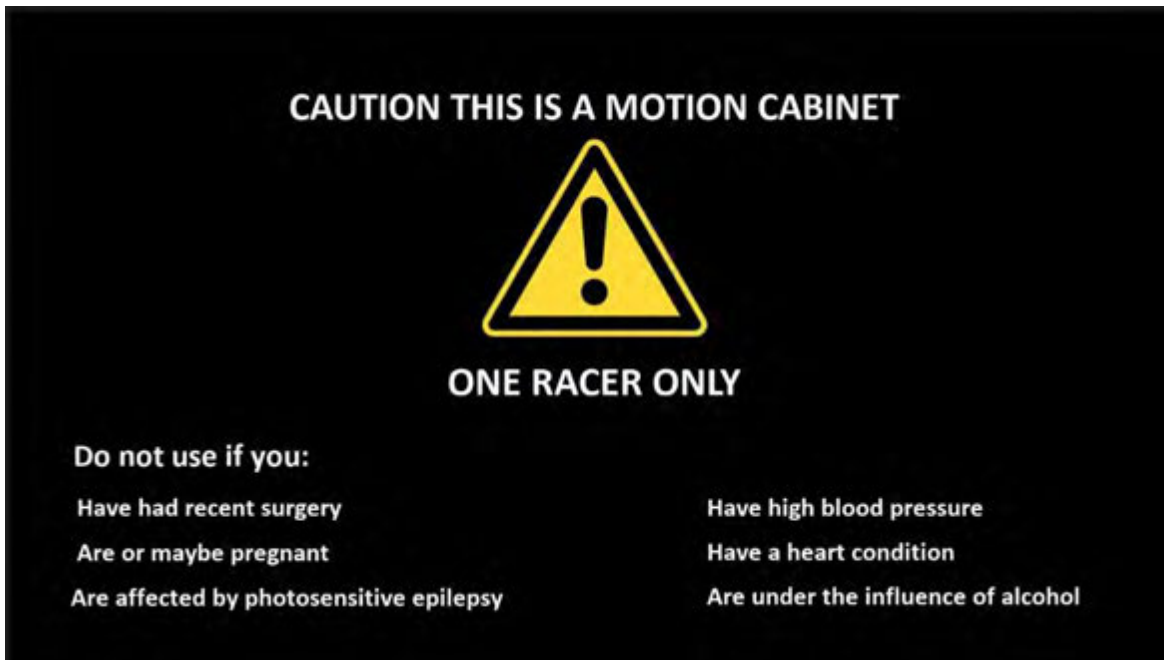



Please fasten your seat belt for
MOTION

Scene 4: Select Track

In the **Track Selection** screen, there are a total of **4** tracks.

Tracks are divided into three difficulty levels: **Standard**, **Advanced** and **Expert**, allowing players to challenge different difficulty levels.

4 Tracks:



Scene 5: Select Vehicle

In the **Vehicle Selection** screen, there are a total of **5** cars with different abilities.

5 Cars:

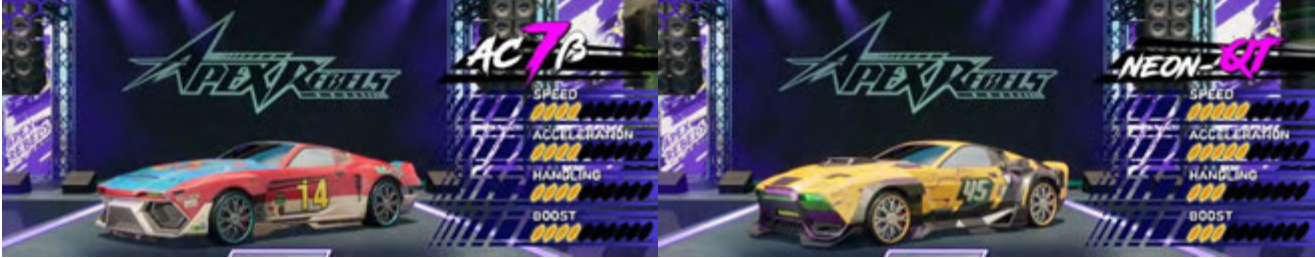

Abilities: **Speed**, **Accelerator**, **Handling** and **Boost**

1: Speed (The maximum speed in the general case)

2: Acceleration (speed of accelerate and overcome the rugged track)

3: Handling (there will be some advantage in inflated road)

4: Boost (that can influence the thunderous value, the value of thunderous acceleration forces)

Scene 6: Waiting Lobby

In a **multi-play race**, after selecting tracks and cars, it will enter the **Lobby Page** showing the **data** of each joined player.

It will show:

- Tracks & Cars selected
- Players' live camera display (if live camera is set to be ON)
- Tips of the game



In a **single-play race (Campaign mode)**, it will show 3 stages.

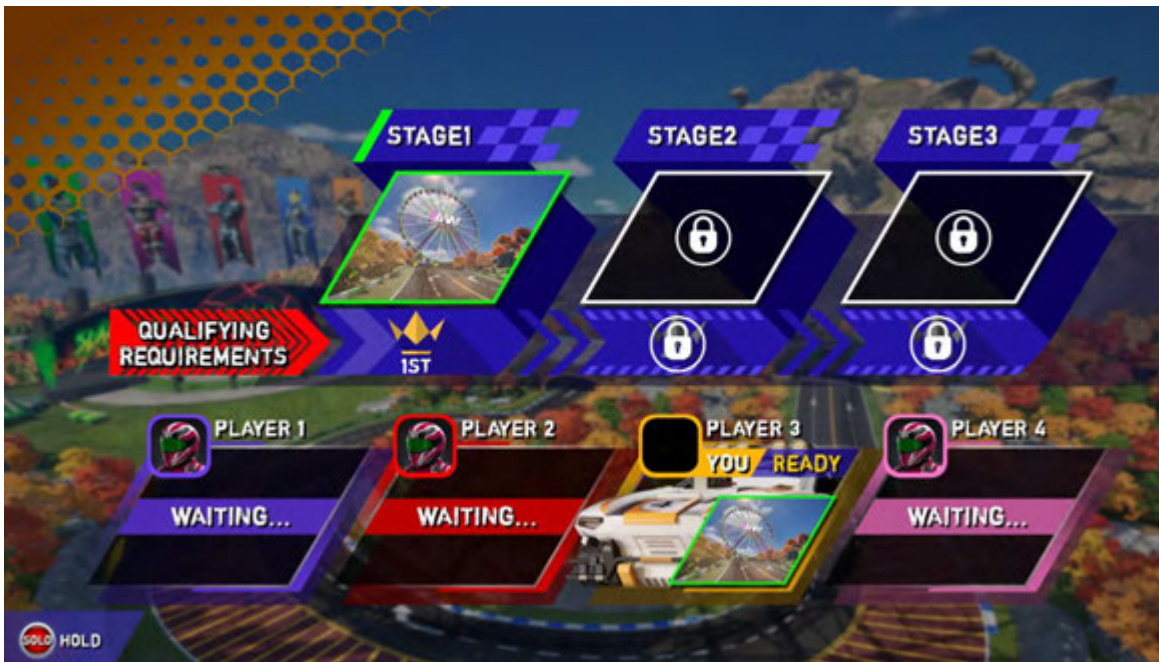

Scene 7: Loading Screen

Learning Tips will be shown in loading screen.



4.2.2 In-Game HUD

Scene 8: In-Game HUD

Game START

Race starts at once right after the loading is finished.



In the Race Start Count Down 3, 2, 1, point the needle of the center speedo to activate ROCKER START.



UI Screen

During the race, data of the race will be displayed around the screen.



1	TIME	Count Down (in seconds)
2	POSITION	Ranking of player
3	SPEEDO	Car Speed (Kilometers per hour/Miles per hour)
4	The 2 nearest players/enemies behind	(display of player's face with Live Camera)
5	BOOST BAR	Boost gained
6	MINI MAP	
7	The 2 nearest players/enemies in front	(display of player's face with Live Camera)
8a 8b	LAP TIME	Time count of current lap
9	TOTAL TIME	Total time of all laps
10	NO. OF LAPS	
11	POSITION LIST	Current position of all players/enemies (appears when finishing each lap)
12	Hints	Hints: Boost MAX/Use Your Boost/Gate Passed...
13	LAST XXXM	Last XXX meters (appears in last 1000meters)
14	TIME EXTENTION	

Scene 9: FINISH Game

Game is finished when player finishes all laps and crosses the finish line or when time is up.



4.2.3 Back-End MENU

Scene 10: Result & Continue Page

After the race is finished, **Ranking** of all players will be shown.

If player can get to the 1st place, a bonus race will be given in the next race.



If player does not come 1st, player will be invited to continue the game in order to challenge the champion again.

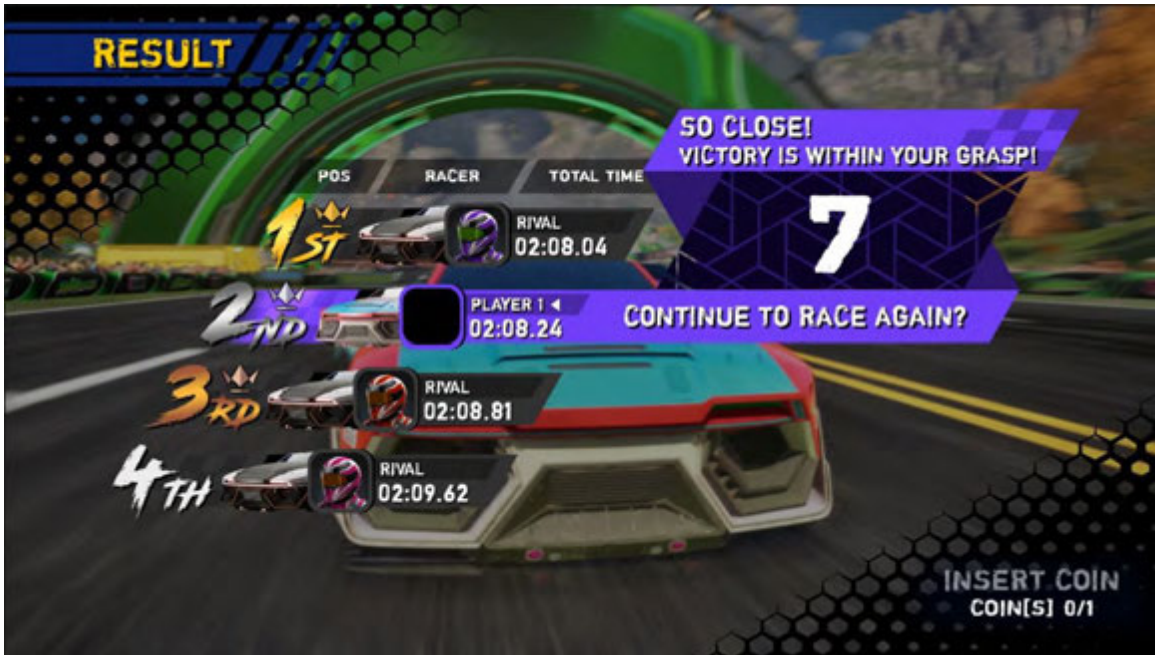

Scene 11: Name Entry

If player does not continue the game, player who is fast enough to enter the ranking board will be asked to enter the name (a maximum of three letters).

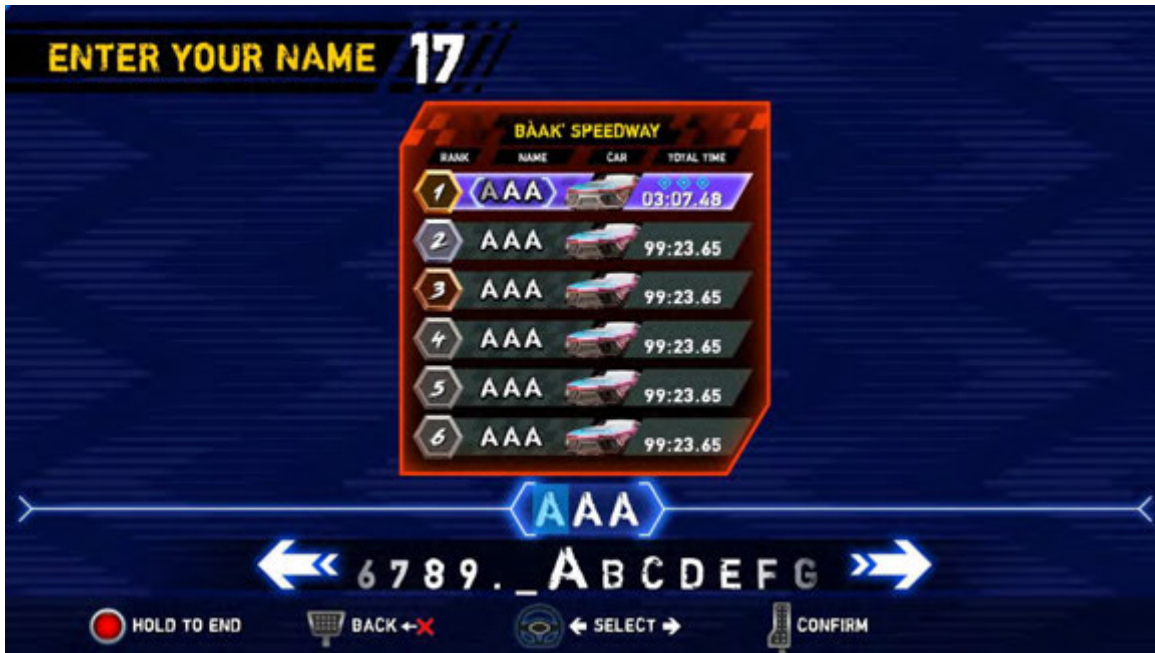

Scene 12: Global Ranking

In Global Racing, it will show the best records of the cabinet in the same race.



Scene 13: Game Over

If player does not continue the game within the time limit, game is over.

Game will be back to **Insert Coin Page**.



4.3 USB Drive Patching

4.3.1 USB Patching Steps:

1. Download the game build and unzip.
2. After unzip the game, you will get a folder which is named “Windows” in it, please renamed it to be [WindowsNoEditor].
3. Prepare a 16GB NTFS format USB drive.
4. Create a folder and named [**ATVCarUpdate**] under the USB drive root directory (e.g. U:\ATVCarUpdate\).
5. Copy the “WindowsNoEditor” under the “ATVCarUpdate”.
6. Boot/re-boot the APEX REBELS MOTION machine.
7. Please insert the USB Drive into the APEX REBELS MOTION machine.
8. The game launcher will start automatically and install the patch from USB drive.
9. After USB patching is completed, please remove the USB drive from APEX REBELS MOTION machine.

Case 3 – Start with Failed Update

Under the below screen, update is required. The loading bar will show the update progress status.

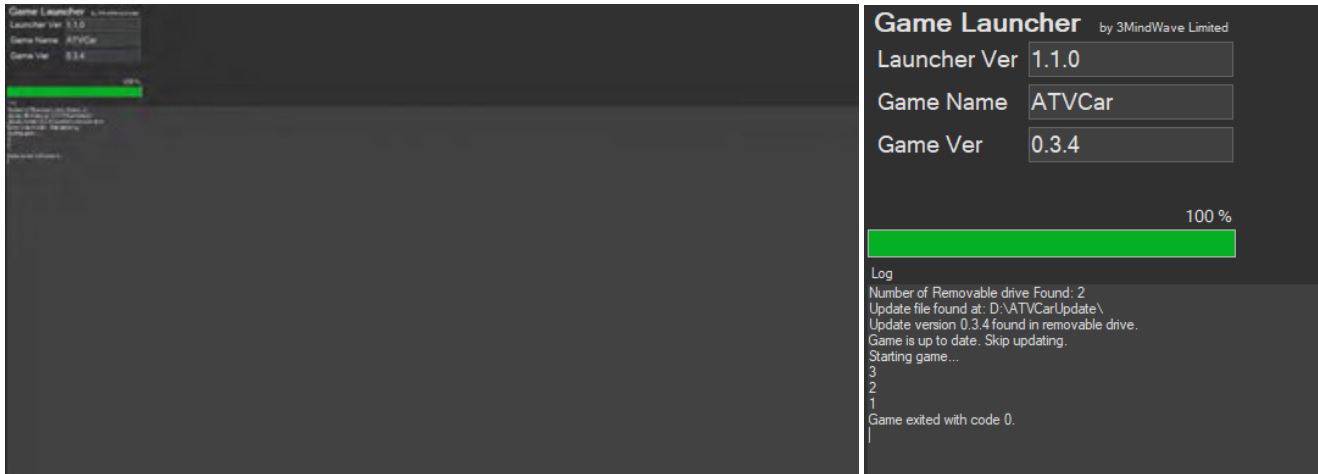

Failure of update will be shown in program code column. Game will start without update after countdown.

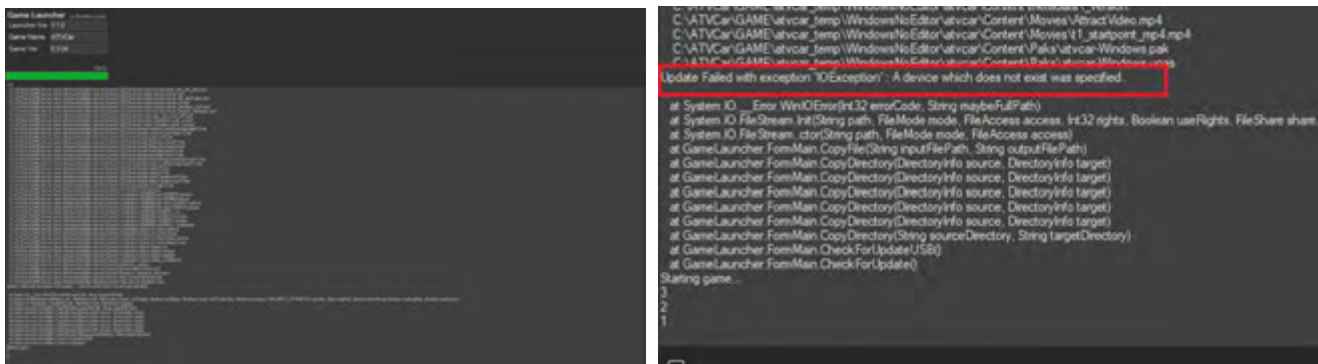

4.4 Operator MENU

AO Test Menu

Buttons	Function
TEST/EXIT	Toggle AO Menu (except in Input Settings)
CYCLE/SELECT	Change option value & Enter to Sub Menu
DOWN	Select next sub Menu / Option
SERVICE	Get a Service credit; Not used in AO Menu

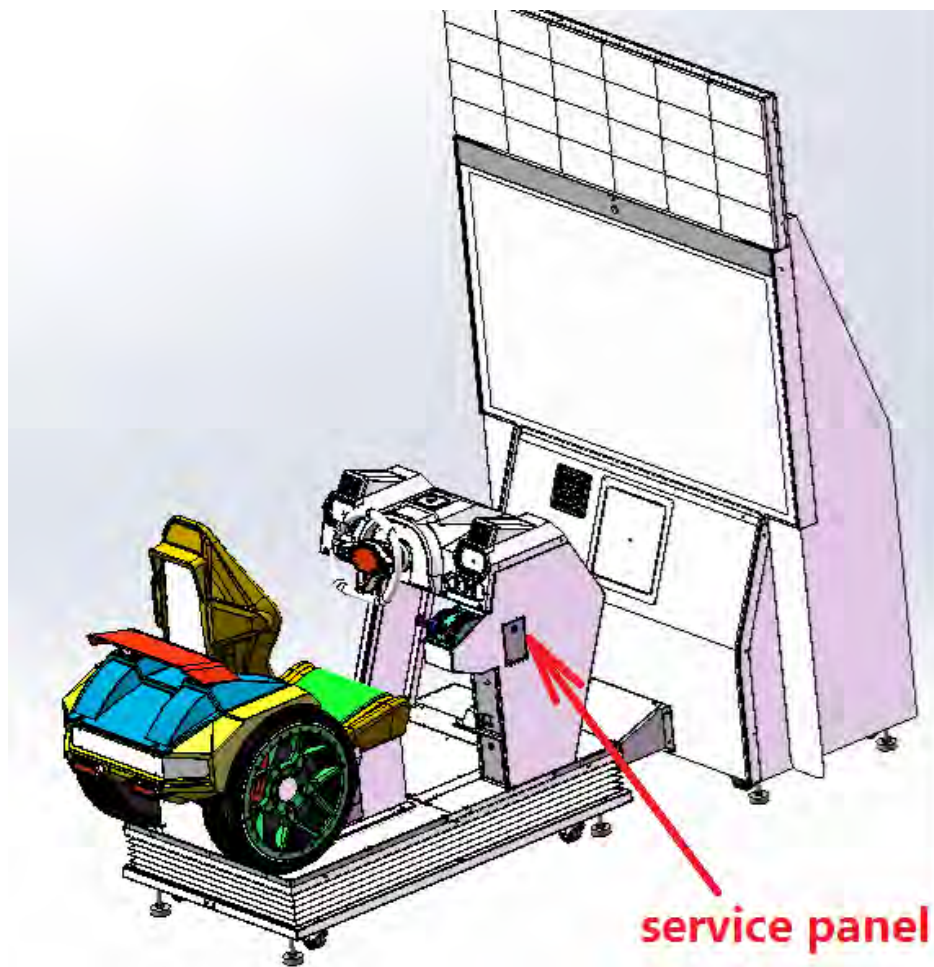

There are switches on the service panel, by using the service panel, it will allow operation of the AO Test Menu.

AO Test Menu



- Under the game **Title Screen**, press the [TEST/EXIT] key of the coin control box to enter the AO [Test Menu], the **main arcade operator** menu is shown as below.
- Setup is saved automatically.
- To exit the **arcade operator** user interface, press the [TEST/EXIT] button. It will go back to the game title screen with new settings.

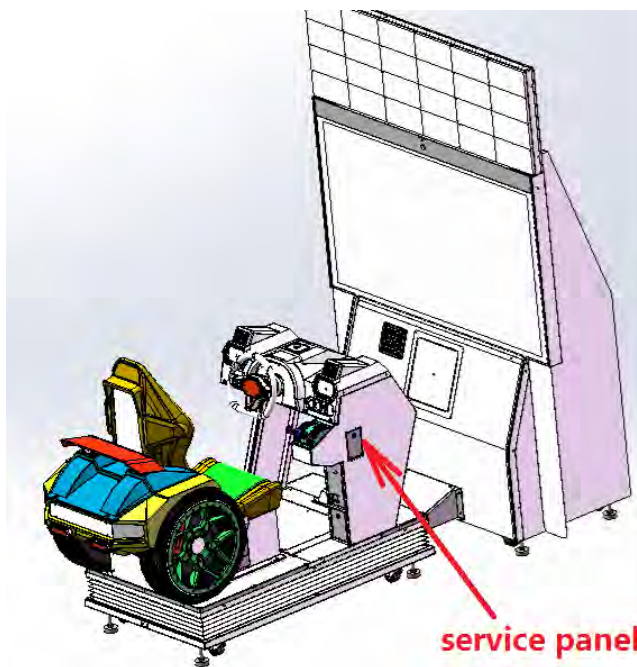

4.4.1 Game Settings

Under **Game Settings**, settings related to game-play can be adjusted here.

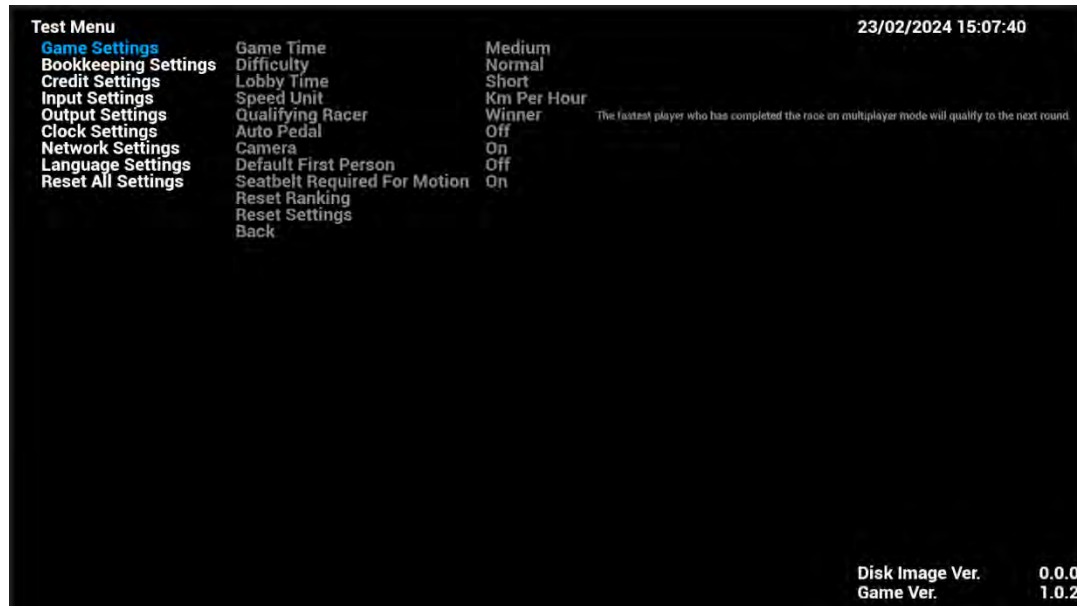

4.4.1-1 Game Time

Under **Game Time**, the length of each game can be adjusted.

Game Time	Description	Timings
Short	2-3 laps	80-120 seconds
Normal	3-5 laps	100-150 seconds
Long	4-7 laps	120-180 seconds

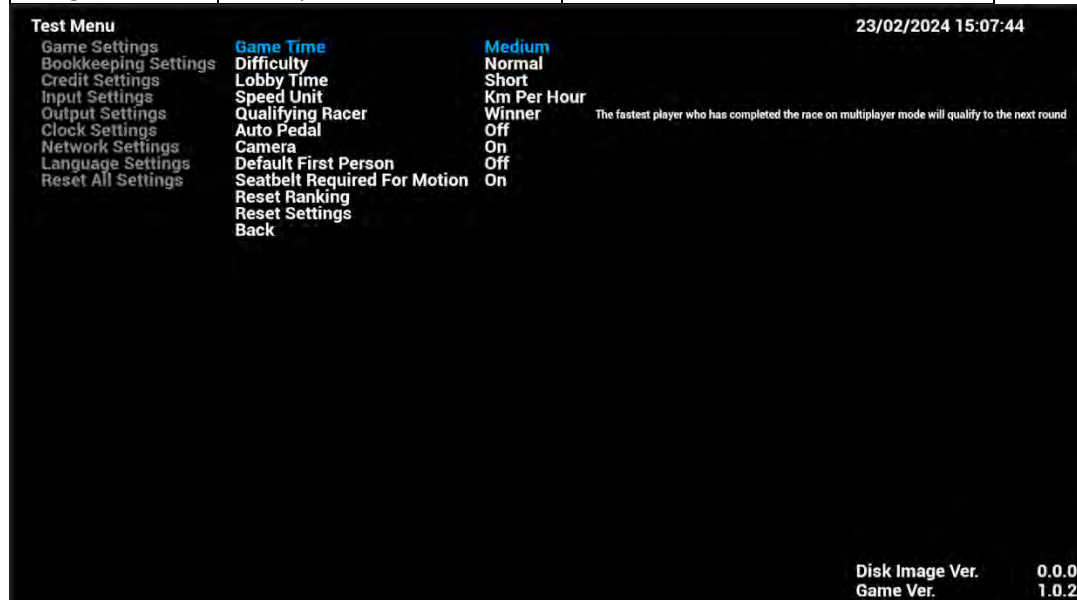

4.4.1-2 Difficulty

Under **Difficulty**, the game hardness can be set.

Difficulty	Description
Easy	Level of game is set to be easy
Normal	Level of game is set to be normal
Hard	Level of game is set to be hard

The screenshot shows the 'Test Menu' with the following settings:

- Game Settings
- Bookkeeping Settings
- Credit Settings
- Input Settings
- Output Settings
- Clock Settings
- Network Settings
- Language Settings
- Reset All Settings

Game Time: Medium
Difficulty: Normal
 Lobby Time: Short
 Speed Unit: Km Per Hour
 Qualifying Racer: Winner
 Auto Pedal: Off
 Camera: On
 Default First Person: Off
 Seatbelt Required For Motion: On
 Reset Ranking
 Reset Settings
 Back

23/02/2024 15:07:45

The fastest player who has completed the race on multiplayer mode will qualify to the next round

Disk Image Ver. 0.0.0
 Game Ver. 1.0.2

4.4.1-3 Lobby Time

Under **Lobby Time**, count down time in menu selection (e.g. select track & bike) can be adjusted.

Lobby Time	Timings
Short	10 seconds
Medium	15 seconds
Long	20 seconds

The screenshot shows the 'Test Menu' with the following settings:

- Game Settings
- Bookkeeping Settings
- Credit Settings
- Input Settings
- Output Settings
- Clock Settings
- Network Settings
- Language Settings
- Reset All Settings

Game Time: Medium
 Difficulty: Normal
Lobby Time: Short
 Speed Unit: Km Per Hour
 Qualifying Racer: Winner
 Auto Pedal: Off
 Camera: On
 Default First Person: Off
 Seatbelt Required For Motion: On
 Reset Ranking
 Reset Settings
 Back

23/02/2024 15:07:47

The fastest player who has completed the race on multiplayer mode will qualify to the next round

Disk Image Ver. 0.0.0
 Game Ver. 1.0.2

4.4.1-4 Speed Unit

Under **Speed Unit**, countdown time in menu selection (e.g. select track & bike) can be adjusted.

Speed Unit	Description
Km/h	Kilometers per hour
MHP	Miles per hour

4.4.1-5 Qualifying Racer

Under **Qualifying Racer**, countdown time in menu selection (e.g. select track & bike) can be adjusted.

Qualifying Racer	
Winner	The fastest player who has completed the race on multiplayer mode will be qualified to the next round
Second Place	
Third Place	
Off	

4.4.1-6 Auto Pedal

Under **Auto Pedal**, auto pedal during gameplay can be turned On/Off.

Auto Pedal	
ON	Auto Pedal is on
OFF	Auto Pedal is off

The screenshot shows the 'Test Menu' with the following settings:

- Game Settings: Medium
- Bookkeeping Settings: Normal
- Credit Settings: Short
- Input Settings: Km Per Hour
- Output Settings: Winner
- Clock Settings: Off
- Network Settings: On
- Language Settings: Off
- Reset All Settings: On
- Game Time: Medium
- Difficulty: Normal
- Lobby Time: Short
- Speed Unit: Km Per Hour
- Qualifying Racer: Winner
- Auto Pedal: Off
- Camera: On
- Default First Person: Off
- Seatbelt Required For Motion: On
- Reset Ranking: On
- Reset Settings: On
- Back: On

Additional information: 23/02/2024 15:07:52, Disk Image Ver. 0.0.0, Game Ver. 1.0.2

4.4.1-7 Camera

Under **Camera**, camera for player's live photo can be turned On/Off.

Camera	Description
On	Camera is on
Off	Camera is off

The screenshot shows the 'Test Menu' with the following settings:

- Game Settings: Medium
- Bookkeeping Settings: Normal
- Credit Settings: Short
- Input Settings: Km Per Hour
- Output Settings: Winner
- Clock Settings: Off
- Network Settings: On
- Language Settings: Off
- Reset All Settings: On
- Game Time: Medium
- Difficulty: Normal
- Lobby Time: Short
- Speed Unit: Km Per Hour
- Qualifying Racer: Winner
- Auto Pedal: Off
- Camera: On
- Default First Person: Off
- Seatbelt Required For Motion: On
- Reset Ranking: On
- Reset Settings: On
- Back: On

Additional information: 23/02/2024 15:07:53, Disk Image Ver. 0.0.0, Game Ver. 1.0.2

4.4.1-8 Default First Person

Under **Default First Person**, whether to set the default in-game view to First Person when game starts.

Default First Person	Description
On	Default First Person is set On
Off	Default First Person is set Off (game default view will be 3 rd -person view)



4.4.1-9 Seatbelt Required For Motion

Under **Seatbelt Required For Motion**, whether it is required to have seatbelt for motion can be adjusted.

Note: *There is a warning message to ensure operators that turning this safety feature off is done at the operators own risk.*

Seatbelt Required For Motion	Description
On	Seatbelt is required For Motion
Off	Seatbelt is not required For Motion



4.4.1-10 Reset Ranking

By complying **Reset Ranking**, all original ranking records on the machine will be cleared. New ranking records will be recorded.

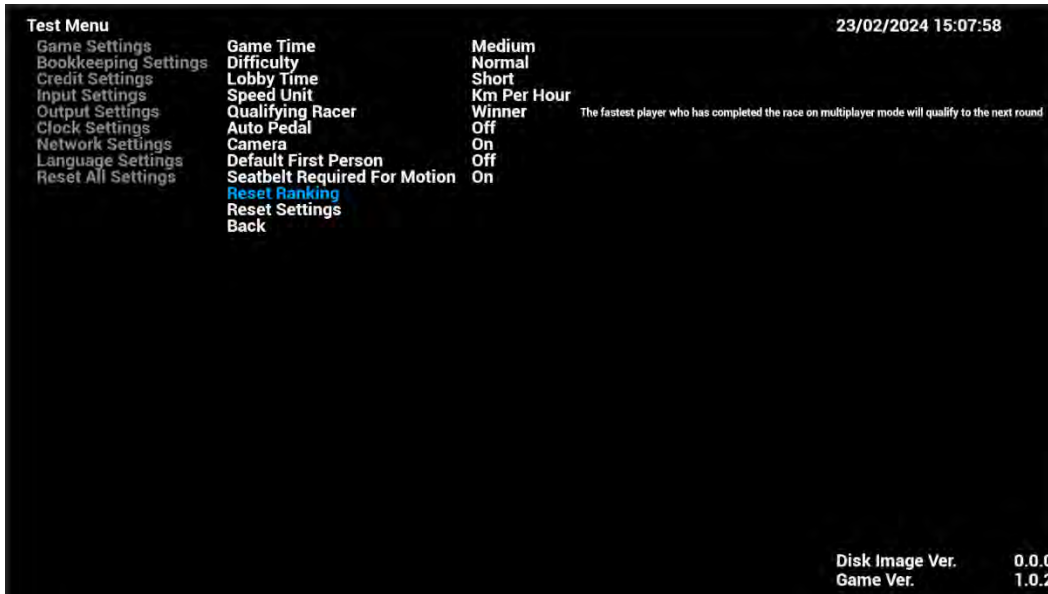

4.4.1-11 Reset Settings

By complying **Reset Settings**, all sub-menu items of **Game Settings** will be reset to default settings.

4.4.2 Bookkeeping Settings

Under **Bookkeeping Settings**, game bookkeeping records of the cabinet can be viewed here.

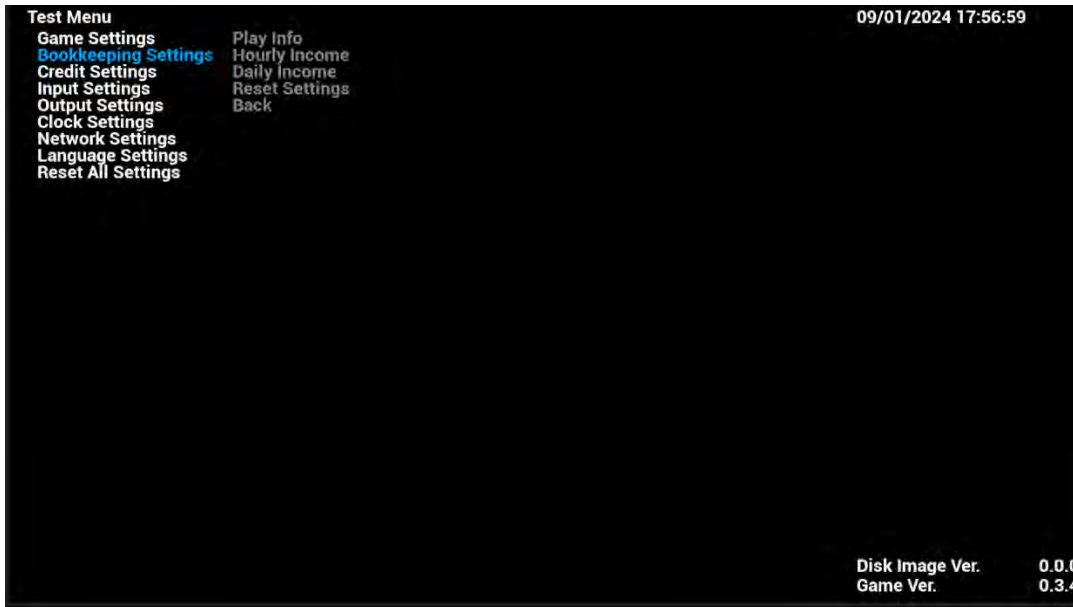

4.4.2-1 Play Info

Under **Play Info**, below game-play data of the cabinet can be viewed.

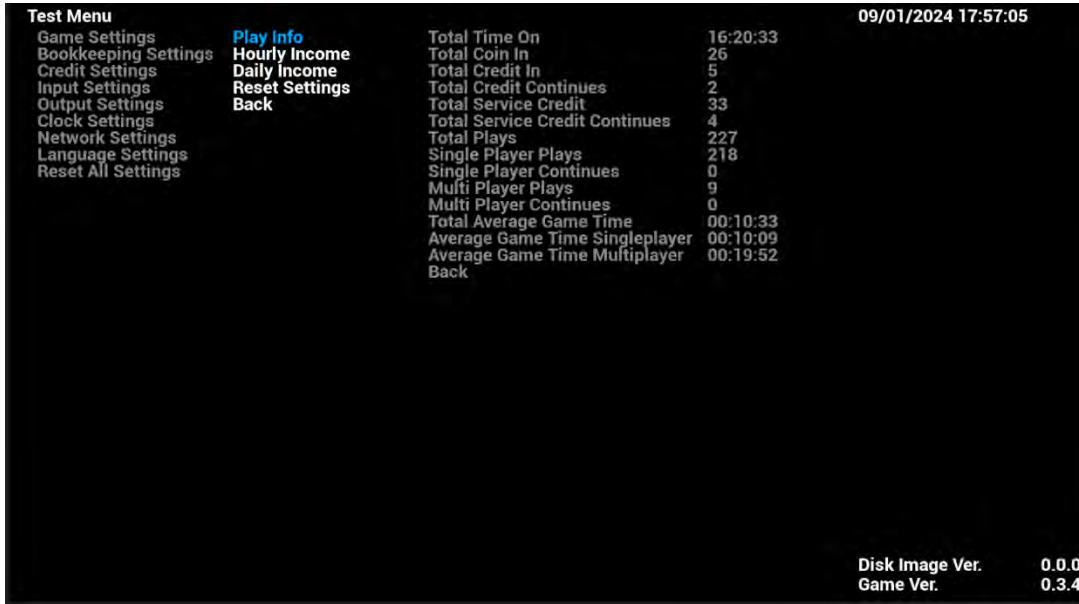

4.4.2-2 Hourly Income

Under **Hourly Income**, income data of the cabinet can be viewed by every hour of the day.

Test Menu	Play Info	09/01/2024 17:57:15
Game Settings	00:00 - 01:00	0
Bookkeeping Settings	01:00 - 02:00	0
Credit Settings	02:00 - 03:00	0
Input Settings	03:00 - 04:00	0
Output Settings	04:00 - 05:00	0
Clock Settings	05:00 - 06:00	0
Network Settings	06:00 - 07:00	0
Language Settings	07:00 - 08:00	0
Reset All Settings	08:00 - 09:00	0
	09:00 - 10:00	0
	10:00 - 11:00	0
	11:00 - 12:00	0
	12:00 - 13:00	0
	13:00 - 14:00	0
	14:00 - 15:00	0
	15:00 - 16:00	5
	16:00 - 17:00	16
	17:00 - 18:00	0
	18:00 - 19:00	5
	19:00 - 20:00	0
	20:00 - 21:00	0
	21:00 - 22:00	0
	22:00 - 23:00	0
	23:00 - 00:00	0
	Back	

Disk Image Ver. 0.0.0
Game Ver. 0.3.4

4.4.2-3 Day Income

Under **Day Income**, income data of the cabinet can be viewed by days of the week.

Test Menu	Play Info	09/01/2024 17:57:23
Game Settings	Monday	21
Bookkeeping Settings	Tuesday	5
Credit Settings	Daily Income	0
Input Settings	Reset Settings	0
Output Settings	Back	0
Clock Settings		0
Network Settings		0
Language Settings		0
Reset All Settings		0

Disk Image Ver. 0.0.0
Game Ver. 0.3.4

4.4.2-4 Reset Settings

By complying **Reset Settings**, all sub-menu items of **Bookkeeping Settings** will be reset to default settings.

4.4.3 Credit Settings

Under **Credit Settings**, settings related to credits can be adjusted here.



4.4.3-1 Credit Count

Under **Credit Count**, total number(s) of credit received by this cabinet will be shown.

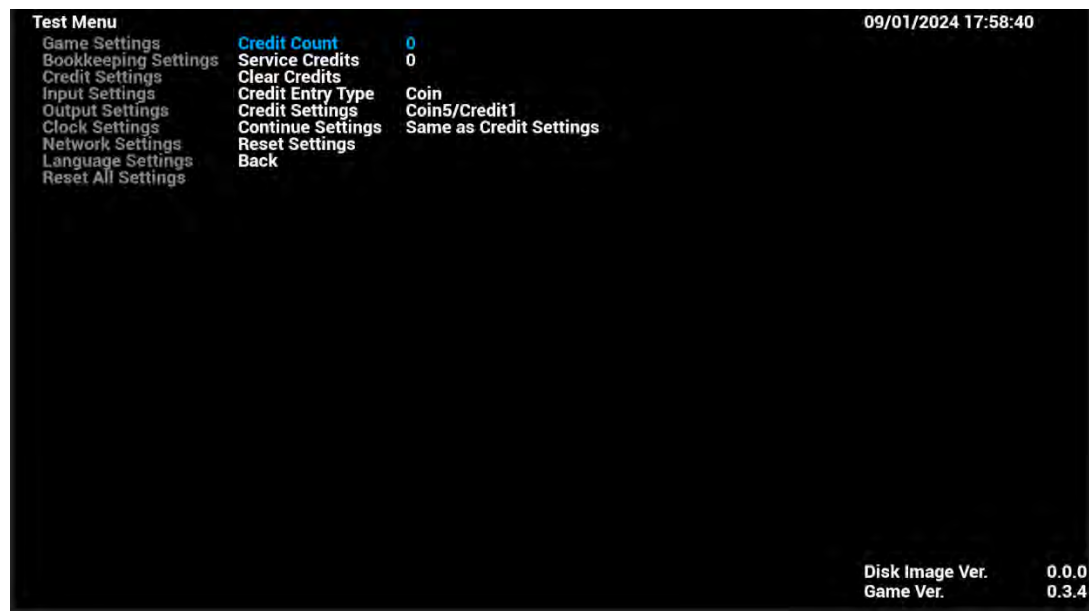

4.4.3-2 Service Credits

Under **Service Credit**, total number(s) of service credit received by this cabinet will be shown.

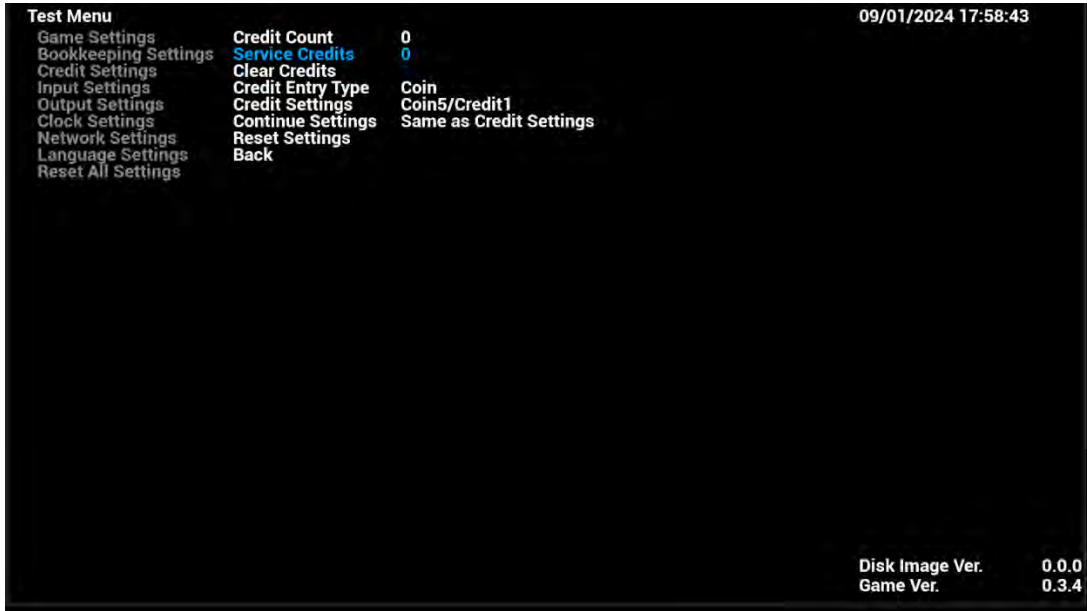

4.4.3-3 Clear Credits

By complying **Clear Credits**, records of **Credit Count** and **Service Credits** will be cleared.



4.4.3-4 Credit Entry Type

Under **Credit Entry Type**, types of credit entry can be adjusted.

Credit Entry Type	Description
Coin	Token of game center
Card Swipe	IC card of game center

The screenshot shows a 'Test Menu' screen with a list of settings on the left and their current values on the right. The 'Credit Entry Type' is set to 'Coin'. The date and time are 09/01/2024 17:58:46. At the bottom right, the 'Disk Image Ver.' is 0.0.0 and the 'Game Ver.' is 0.3.4.

Test Menu	Value
Credit Count	0
Service Credits	0
Clear Credits	
Credit Entry Type	Coin
Credit Settings	Coin5/Credit1
Continue Settings	Same as Credit Settings
Reset Settings	
Back	

4.4.3-5 Credit Settings

Under **Credit Settings**, types of credit entry can be adjusted.

Credit Settings	Description
Free Play	Game is free to play (no credit is needed)
X Coins X Credit	No. of Coins for No. of Credit per game can be set (a max. 20conins per play)

The screenshot shows a 'Test Menu' screen with a list of settings on the left and their current values on the right. The 'Credit Settings' is set to 'Coin5/Credit1'. The date and time are 09/01/2024 17:58:48. At the bottom right, the 'Disk Image Ver.' is 0.0.0 and the 'Game Ver.' is 0.3.4.

Test Menu	Value
Credit Count	0
Service Credits	0
Clear Credits	
Credit Entry Type	Coin
Credit Settings	Coin5/Credit1
Continue Settings	Same as Credit Settings
Reset Settings	
Back	

4.4.3-6 Continue Settings

Under **Continue Settings**, types of credit entry can be adjusted.

Continue Settings	Description
Same as Credit Settings	Same setting as Credit Settings
X Coins X Credit	No. of Coins for No. of Credit per game can be set



4.4.3-7 Reset Settings

By complying **Reset Settings**, all sub-menu items of **Credit Settings** will be reset to default settings.

4.4.4 Input Settings

Under **Input Settings**, settings related to game input can be adjusted here.

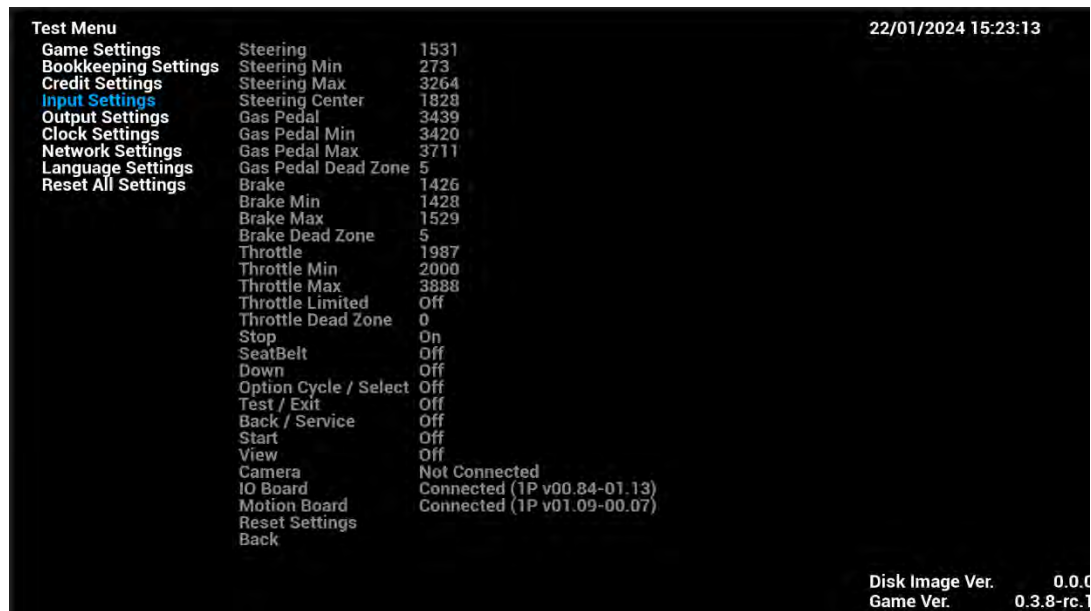

4.4.4-1 Steering

Under **Steering**, handle steering range will be detected automatically and shown here.

Steering	Description
Steering Min	Turn the steering wheel counterclockwise to the far left, then press the Select key. Steering Min will record the minimum value of the steering wheel.
Steering Max	Turn the steering wheel clockwise to the far right and then press the Select button. Steering Max will record the maximum value of the steering wheel.
Steering Center	Turn the steering wheel so that the steering wheel is in the middle position, and then press the Select key. The Steering Center will record the value of the steering wheel's middle position.

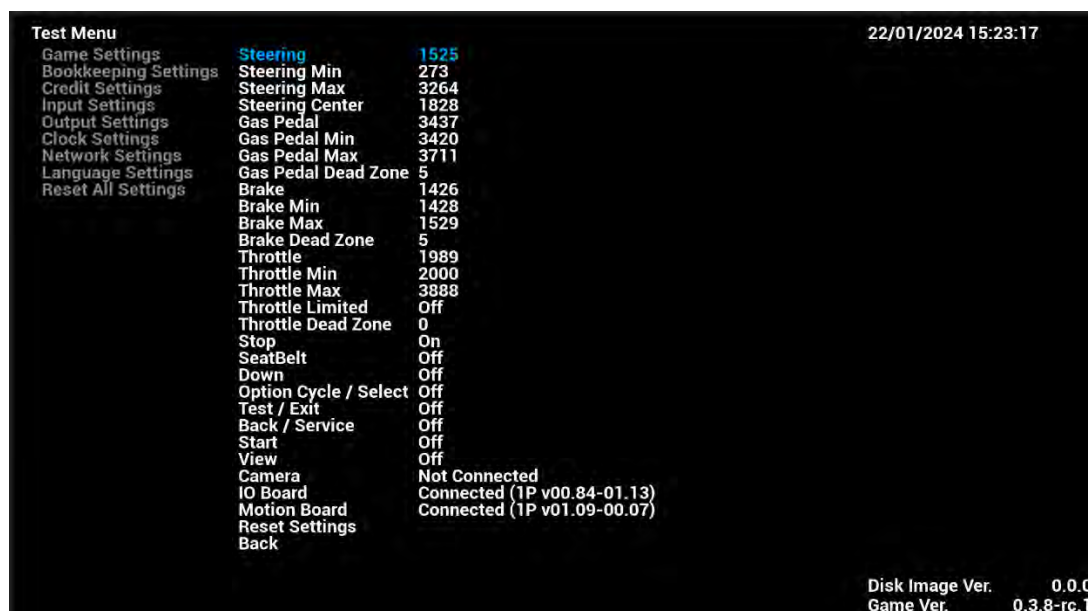

4.4.4-2 Steering Min

Under **Steering Min**, minimum value (i.e. Left-turn torque of the steering handle) of handle steering range will be detected automatically and shown here.

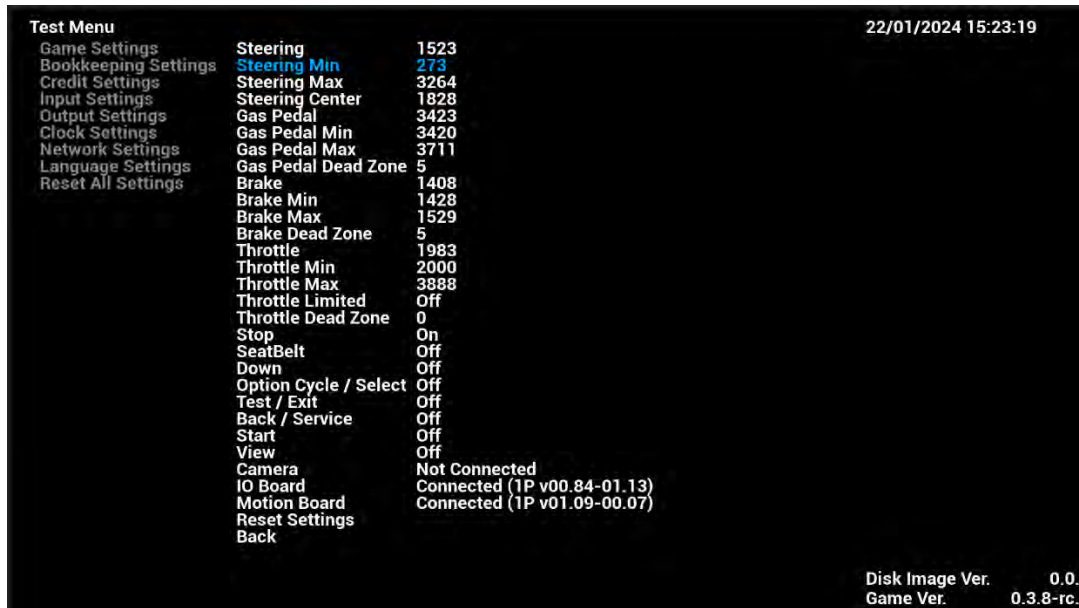

4.4.4-3 Steering Max

Under **Steering Max**, maximum value (i.e. Right-turn torque of the steering handle) of handle steering range will be detected automatically and shown here.

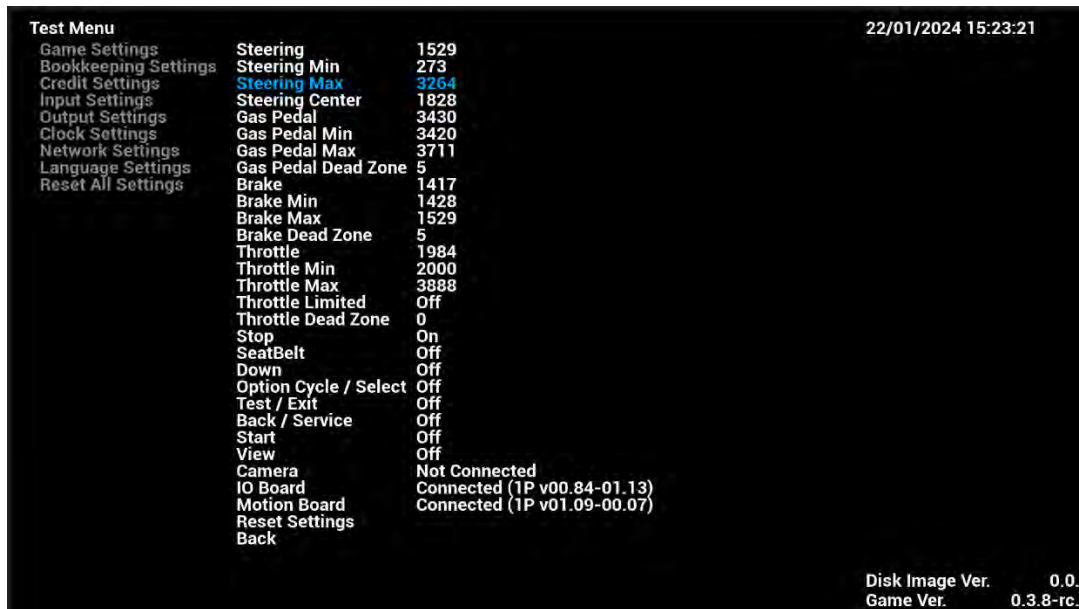

4.4.4-4 Steering Center

Under **Steering Center**, center position value of handle steering range will be detected automatically and shown here.

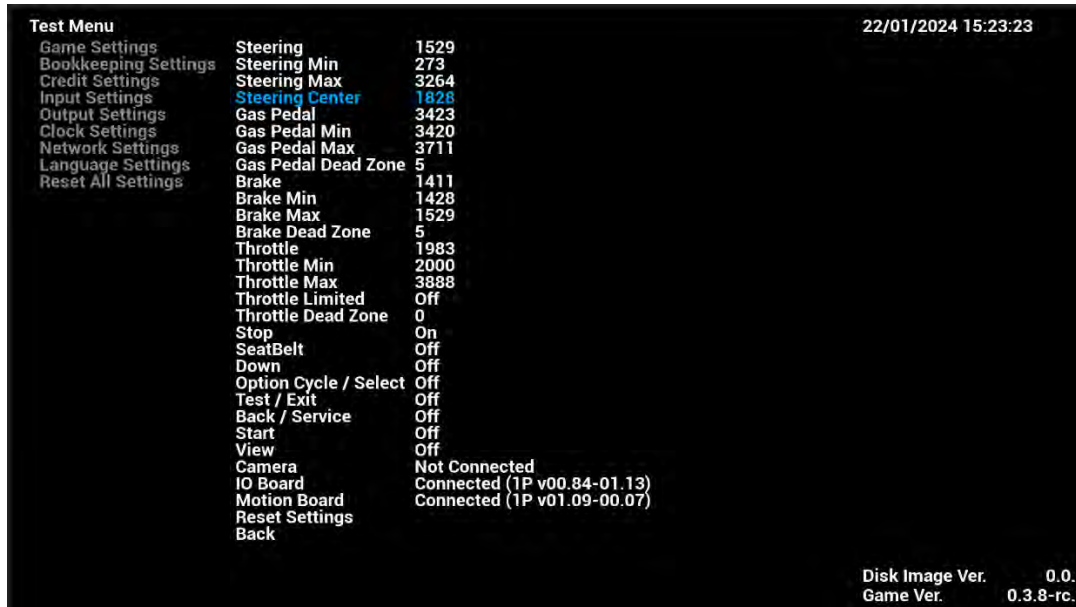

4.4.4-5 Gas Pedal

Under **Gas Pedal**, gas pedal range will be detected automatically and shown here.

Gas Pedal	Description
Gas Pedal Min	Release the accelerator pedal and press the SELECT button. Gas Pedal Min will record the minimum value of the accelerator pedal.
Gas Pedal Max	Step onto the accelerator pedal and then press the SELECT button. Gas Pedal Max will record the maximum value of the accelerator.

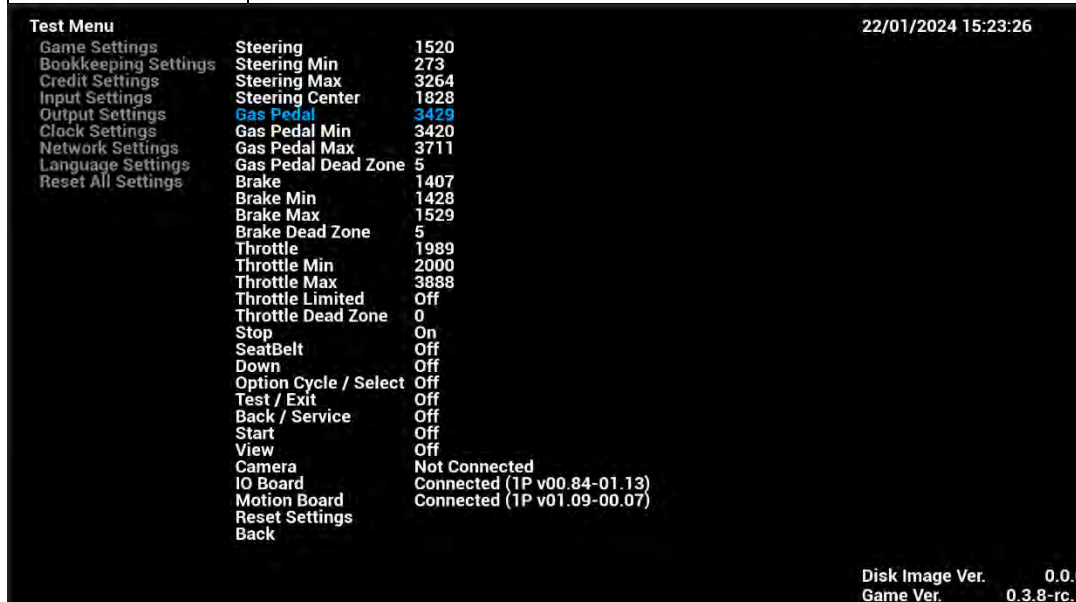

4.4.4-6 Gas Pedal Min

Under **Gas Pedal Min**, minimum value of gas pedal range will be detected automatically and shown here.

The screenshot shows a 'Test Menu' interface with a list of settings and their values. The 'Gas Pedal Min' value is highlighted in blue and is 3420. The interface also shows a date and time of 22/01/2024 15:23:28 and version information at the bottom right.

Setting	Value
Steering	1522
Steering Min	273
Steering Max	3264
Steering Center	1828
Gas Pedal	3436
Gas Pedal Min	3420
Gas Pedal Max	3711
Gas Pedal Dead Zone	5
Brake	1426
Brake Min	1428
Brake Max	1529
Brake Dead Zone	5
Throttle	1987
Throttle Min	2000
Throttle Max	3888
Throttle Limited	Off
Throttle Dead Zone	0
Stop	On
SeatBelt	Off
Down	Off
Option Cycle / Select	Off
Test / Exit	Off
Back / Service	Off
Start	Off
View	Off
Camera	Not Connected
IO Board	Connected (1P v00.84-01.13)
Motion Board	Connected (1P v01.09-00.07)
Reset Settings	
Back	

Disk Image Ver. 0.0.0
Game Ver. 0.3.8-rc.1

4.4.4-7 Gas Pedal Max

Under **Gas Pedal Max**, maximum value of gas pedal range will be detected automatically and shown here.

The screenshot shows a 'Test Menu' interface with a list of settings and their values. The 'Gas Pedal Max' value is highlighted in blue and is 3711. The interface also shows a date and time of 22/01/2024 15:23:30 and version information at the bottom right.

Setting	Value
Steering	1533
Steering Min	273
Steering Max	3264
Steering Center	1828
Gas Pedal	3439
Gas Pedal Min	3420
Gas Pedal Max	3711
Gas Pedal Dead Zone	5
Brake	1429
Brake Min	1428
Brake Max	1529
Brake Dead Zone	5
Throttle	1986
Throttle Min	2000
Throttle Max	3888
Throttle Limited	Off
Throttle Dead Zone	0
Stop	On
SeatBelt	Off
Down	Off
Option Cycle / Select	Off
Test / Exit	Off
Back / Service	Off
Start	Off
View	Off
Camera	Not Connected
IO Board	Connected (1P v00.84-01.13)
Motion Board	Connected (1P v01.09-00.07)
Reset Settings	
Back	

Disk Image Ver. 0.0.0
Game Ver. 0.3.8-rc.1

4.4.4-8 Gas Pedal Dead Zone

Under **Gas Pedal Dead Zone**, deadzone of gas pedal can be calibrated only when Gas Pedal value is detected.

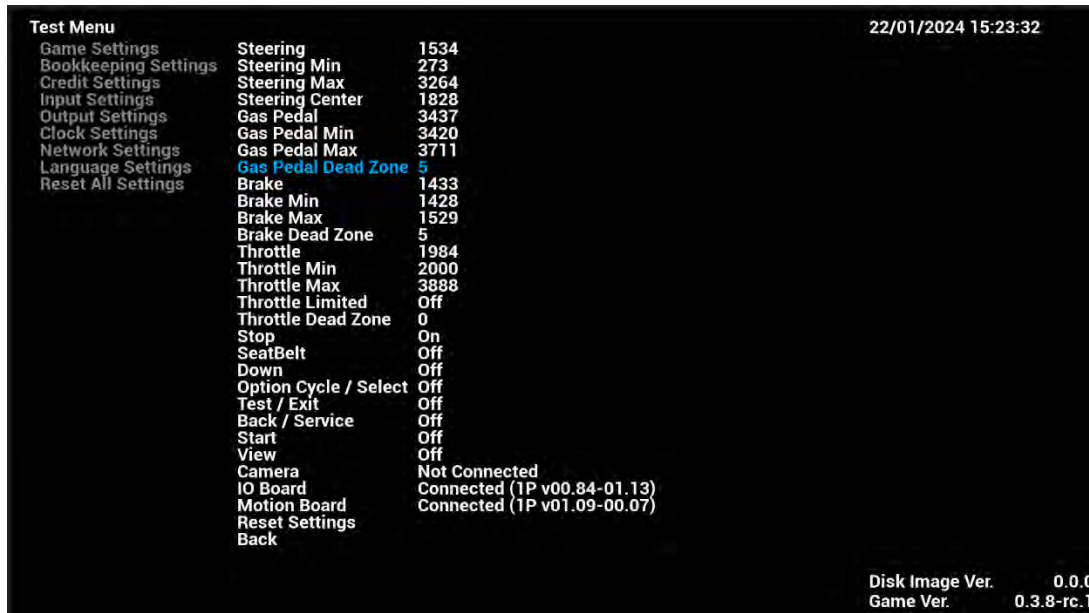

4.4.4-9 Brake

Under **Brake**, brake pedal range will be detected automatically and shown here.

Brake	Description
Brake Min	Release the brake pedal and press the SELECT button. Brake Min will record the minimum braking value.
Brake Max	Step onto the brake pedal and then press the SELECT button. Brake Max will record the maximum braking value.

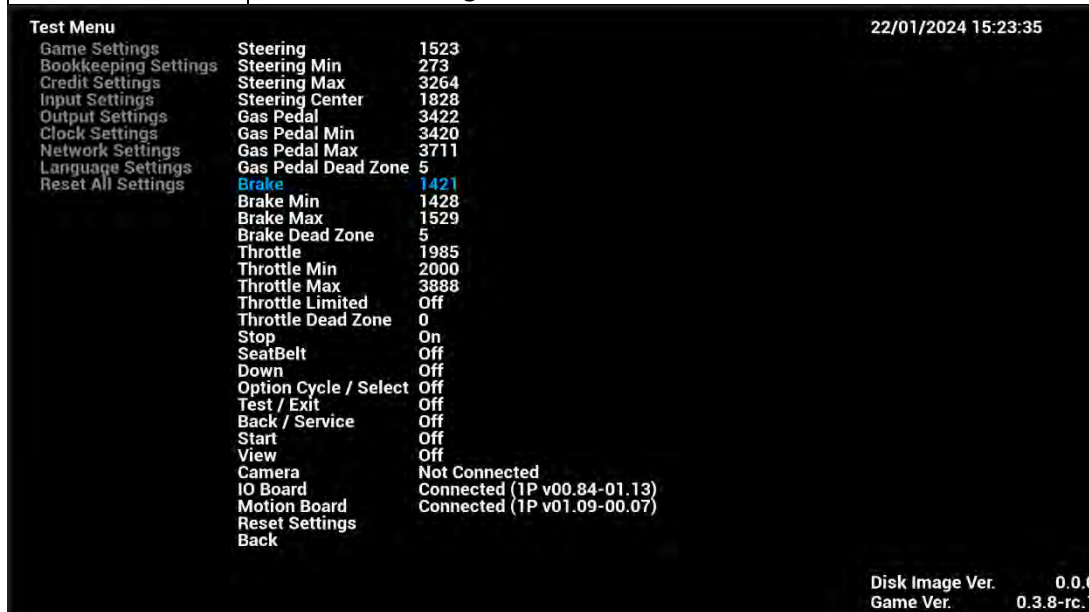

4.4.4-10 Brake Min

Under **Brake Min**, minimum value of brake pedal range will be detected automatically and shown here.

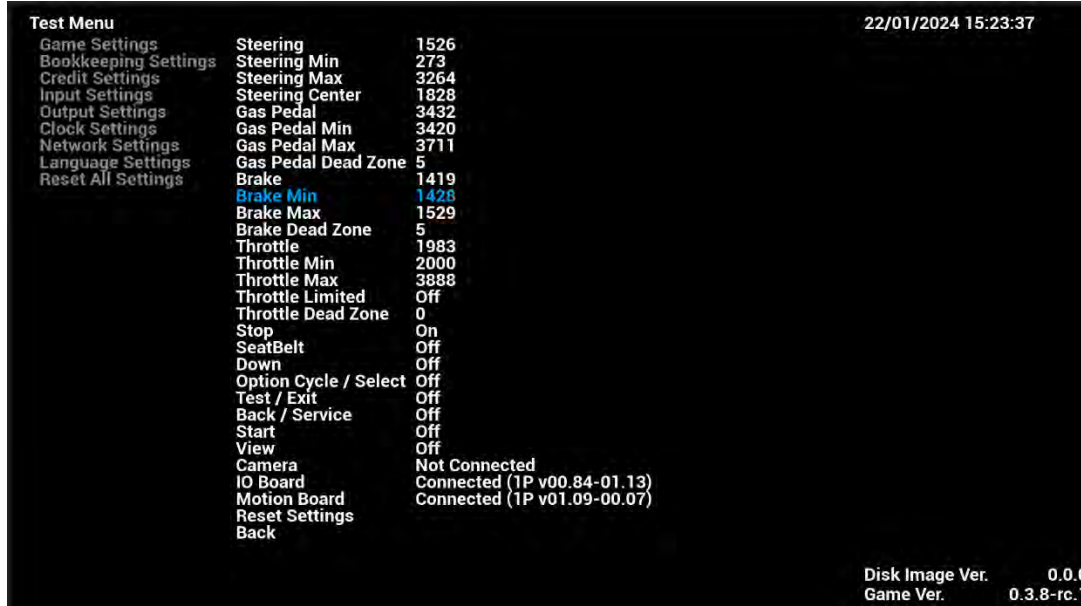

4.4.4-11 Brake Max

Under **Brake Max**, maximum value of brake pedal range will be detected automatically and shown here.

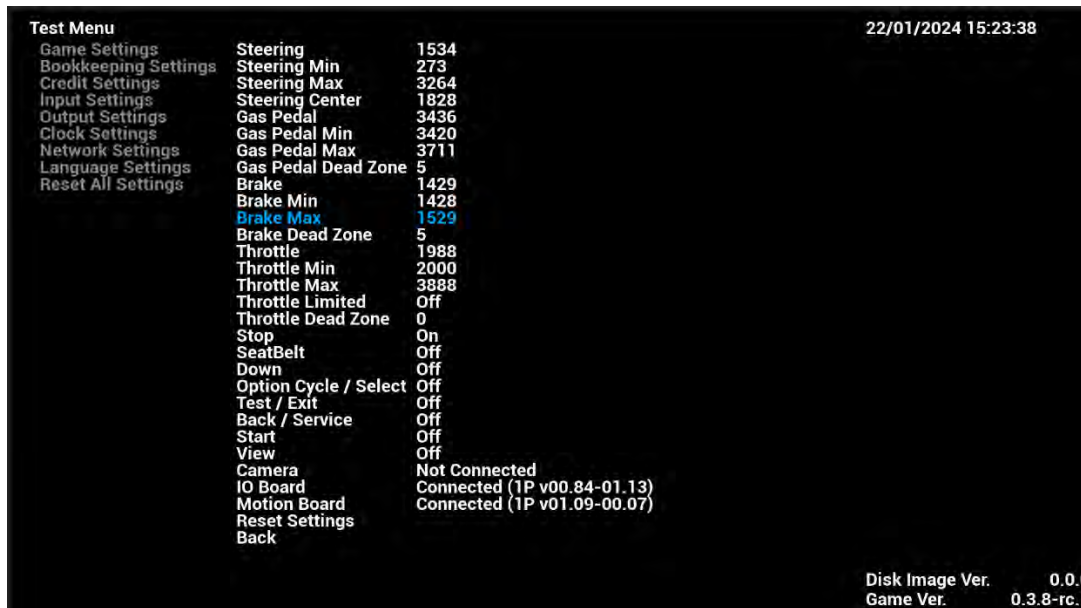

4.4.4-12 Brake Dead Zone

Under **Brake Pedal Dead Zone**, deadzone of brake can be calibrated only when Brake Pedal value is detected.

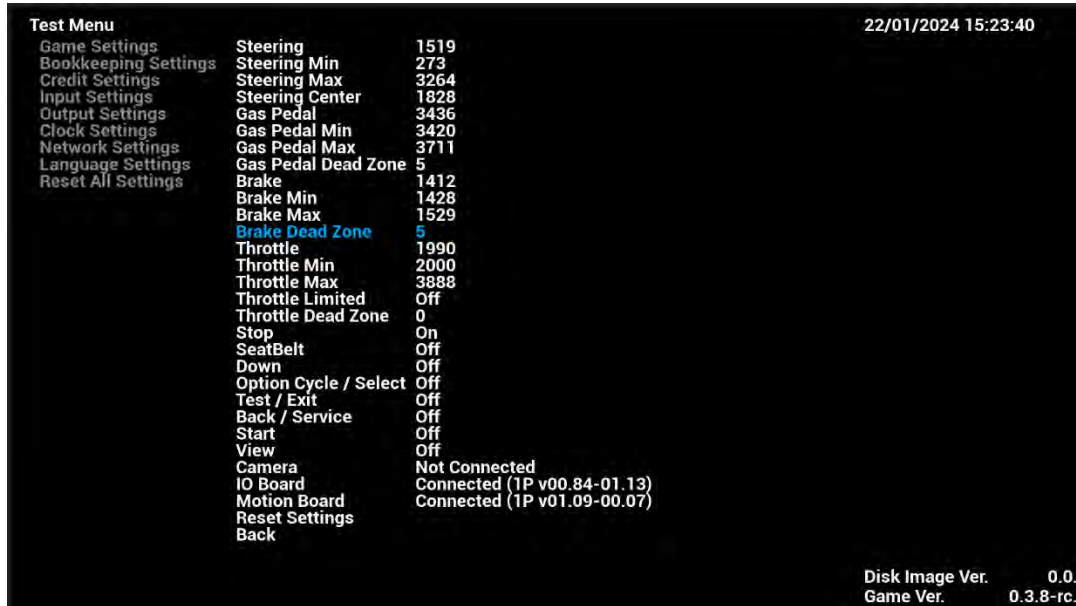

4.4.4-13 Throttle

Under **Throttle**, throttle range will be detected automatically and shown here.

Throttle	Description
Throttle Min	Pull down the gear and press the SELECT button. Throttle Min will record the minimum value of the gear.
Throttle Max	Push up the gear and then press the SELECT button. Throttle Max will record the maximum value of the gear.

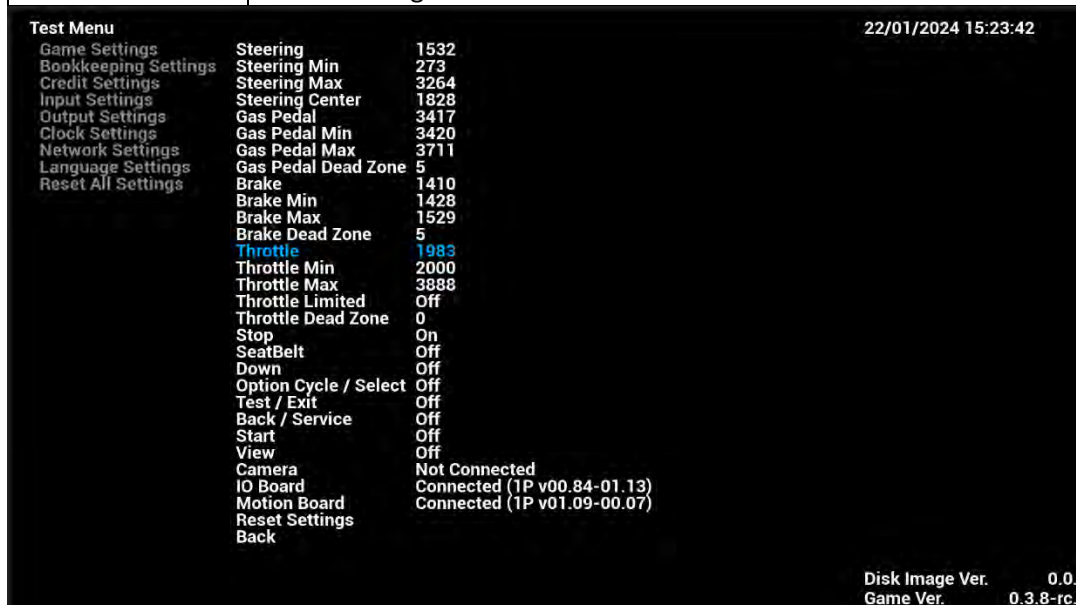

4.4.4-14 Throttle Min

Under **Throttle Min**, minimum value of throttle range will be detected automatically and shown here.

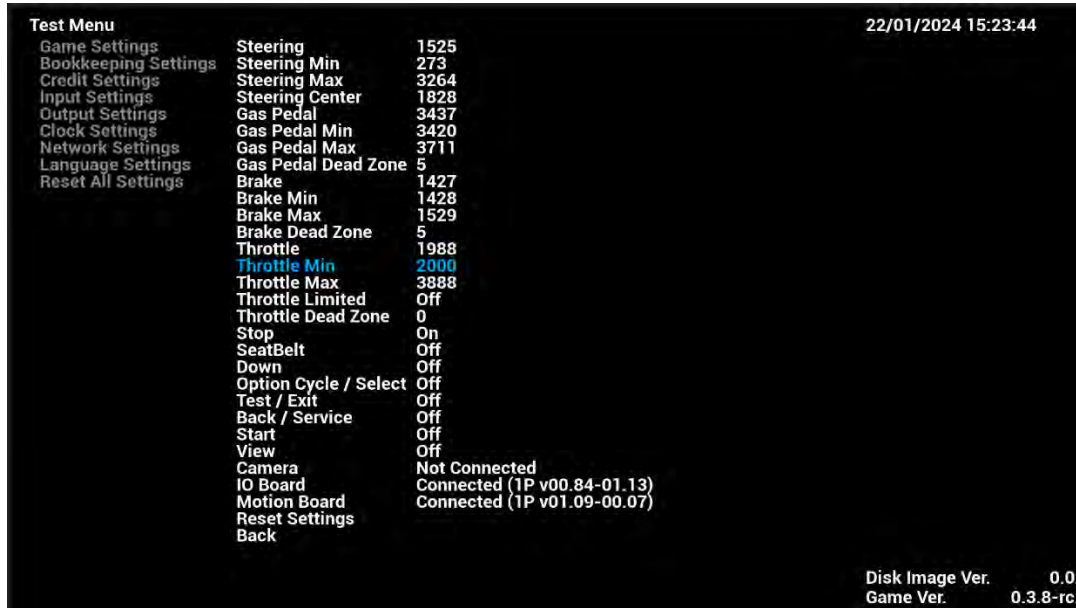

4.4.4-15 Throttle Max

Under **Throttle Max**, maximum value of throttle range will be detected automatically and shown here.

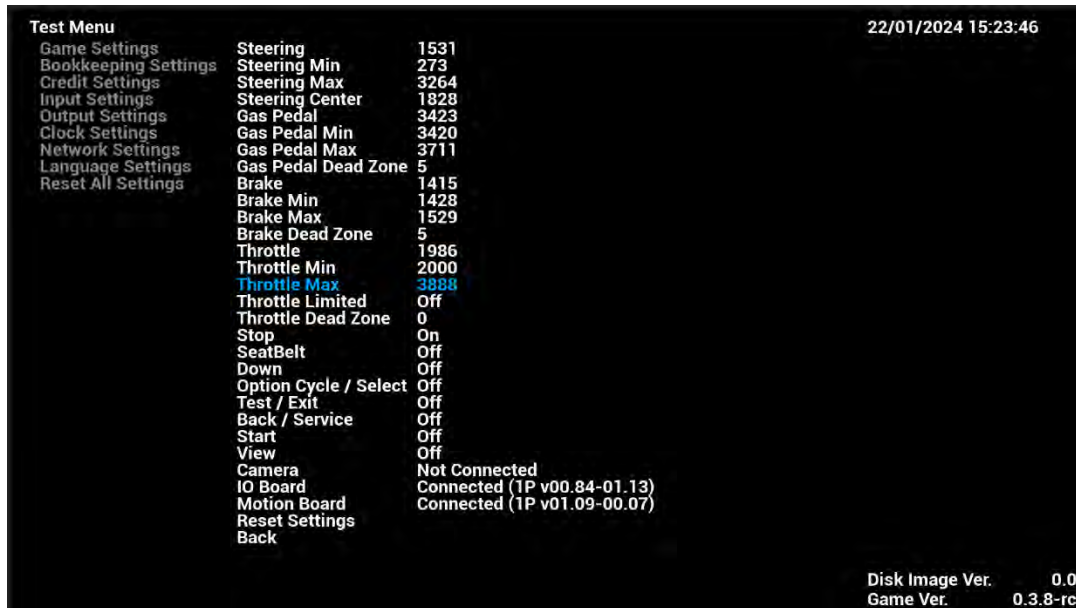

4.4.4-16 Throttle Limited

Under **Throttle Limited**, whether Throttle Limited (i.e. Max Switch) is set ON/OFF will be detected.

Throttle Limited (Max Switch)	Description
On	Throttle Limited is ON
Off	Throttle Limited is OFF

22/01/2024 15:23:48

Game Settings	Steering	1532
Bookkeeping Settings	Steering Min	273
Credit Settings	Steering Max	3264
Input Settings	Steering Center	1828
Output Settings	Gas Pedal	3432
Clock Settings	Gas Pedal Min	3420
Network Settings	Gas Pedal Max	3711
Language Settings	Gas Pedal Dead Zone	5
Reset All Settings	Brake	1411
	Brake Min	1428
	Brake Max	1529
	Brake Dead Zone	5
	Throttle	1983
	Throttle Min	2000
	Throttle Max	3888
	Throttle Limited	Off
	Throttle Dead Zone	0
	Stop	On
	SeatBelt	Off
	Down	Off
	Option Cycle / Select	Off
	Test / Exit	Off
	Back / Service	Off
	Start	Off
	View	Off
	Camera	Not Connected
	IO Board	Connected (1P v00.84-01.13)
	Motion Board	Connected (1P v01.09-00.07)
	Reset Settings	
	Back	

Disk Image Ver. 0.0.0
Game Ver. 0.3.8-rc.1

4.4.4-17 Throttle Dead Zone

Under **Throttle Dead Zone**, deadzone of throttle can be calibrated only when Throttle value is detected.

22/01/2024 15:23:50

Game Settings	Steering	1519
Bookkeeping Settings	Steering Min	273
Credit Settings	Steering Max	3264
Input Settings	Steering Center	1828
Output Settings	Gas Pedal	3438
Clock Settings	Gas Pedal Min	3420
Network Settings	Gas Pedal Max	3711
Language Settings	Gas Pedal Dead Zone	5
Reset All Settings	Brake	1413
	Brake Min	1428
	Brake Max	1529
	Brake Dead Zone	5
	Throttle	1986
	Throttle Min	2000
	Throttle Max	3888
	Throttle Limited	Off
	Throttle Dead Zone	0
	Stop	On
	SeatBelt	Off
	Down	Off
	Option Cycle / Select	Off
	Test / Exit	Off
	Back / Service	Off
	Start	Off
	View	Off
	Camera	Not Connected
	IO Board	Connected (1P v00.84-01.13)
	Motion Board	Connected (1P v01.09-00.07)
	Reset Settings	
	Back	

Disk Image Ver. 0.0.0
Game Ver. 0.3.8-rc.1

4.4.4-18 Stop

Under **Stop**, whether (Motion) STOP button is set ON/OFF will be detected.

Stop	Description
On	Motion Stop Button is detected ON
Off	Motion Stop Button is detected OFF

```

Test Menu
Game Settings      Steering      1519
Bookkeeping Settings Steering Min   273
Credit Settings   Steering Max  3264
Input Settings    Steering Center 1828
Output Settings   Gas Pedal     3436
Clock Settings    Gas Pedal Min  3420
Network Settings  Gas Pedal Max  3711
Language Settings Gas Pedal Dead Zone 5
Reset All Settings Brake         1421
                  Brake Min     1428
                  Brake Max     1529
                  Brake Dead Zone 5
                  Throttle      1987
                  Throttle Min   2000
                  Throttle Max   3888
                  Throttle Limited Off
                  Throttle Dead Zone 0
Stop              On
SeatBelt          Off
Down              Off
Option Cycle / Select Off
Test / Exit       Off
Back / Service    Off
Start             Off
View              Off
Camera            Not Connected
IO Board          Connected (1P v00.84-01.13)
Motion Board      Connected (1P v01.09-00.07)
Reset Settings
Back

Disk Image Ver. 0.0.0
Game Ver. 0.3.8-rc.1
    
```

4.4.4-19 SeatBelt

Under **SeatBelt**, whether SeatBelt Requirement is set ON/OFF will be detected.

Seatbelt	Description
On	Seatbelt Required is detected ON
Off	Seatbelt Required is detected OFF

```

Test Menu
Game Settings      Steering      1520
Bookkeeping Settings Steering Min   273
Credit Settings   Steering Max  3264
Input Settings    Steering Center 1828
Output Settings   Gas Pedal     3422
Clock Settings    Gas Pedal Min  3420
Network Settings  Gas Pedal Max  3711
Language Settings Gas Pedal Dead Zone 5
Reset All Settings Brake         1417
                  Brake Min     1428
                  Brake Max     1529
                  Brake Dead Zone 5
                  Throttle      1983
                  Throttle Min   2000
                  Throttle Max   3888
                  Throttle Limited Off
                  Throttle Dead Zone 0
Stop              On
SeatBelt          Off
Down              Off
Option Cycle / Select Off
Test / Exit       Off
Back / Service    Off
Start             Off
View              Off
Camera            Not Connected
IO Board          Connected (1P v00.84-01.13)
Motion Board      Connected (1P v01.09-00.07)
Reset Settings
Back

Disk Image Ver. 0.0.0
Game Ver. 0.3.8-rc.1
    
```

4.4.4-20 Down

Under **Down**, whether DOWN AO Button is set ON/OFF will be detected.

Down	Description
On	Down AO button is detected ON
Off	Down AO button is detected OFF

Test Menu 22/01/2024 15:23:55

Game Settings	Steering	1528
Bookkeeping Settings	Steering Min	273
Credit Settings	Steering Max	3264
Input Settings	Steering Center	1828
Output Settings	Gas Pedal	3415
Clock Settings	Gas Pedal Min	3420
Network Settings	Gas Pedal Max	3711
Language Settings	Gas Pedal Dead Zone	5
Reset All Settings	Brake	1411
	Brake Min	1428
	Brake Max	1529
	Brake Dead Zone	5
	Throttle	1983
	Throttle Min	2000
	Throttle Max	3888
	Throttle Limited	Off
	Throttle Dead Zone	0
	Stop	On
	SeatBelt	Off
	Down	Off
	Option Cycle / Select	Off
	Test / Exit	Off
	Back / Service	Off
	Start	Off
	View	Off
	Camera	Not Connected
	IO Board	Connected (1P v00.84-01.13)
	Motion Board	Connected (1P v01.09-00.07)
	Reset Settings	
	Back	

Disk Image Ver. 0.0.0
Game Ver. 0.3.8-rc.1

4.4.4-21 Option Cycle / Select

Under **Option Cycle / Select**, whether **Option Cycle / Select** AO Button is set ON/OFF will be detected.

Option Cycle / Select	Description
On	Option Cycle / Select AO button is detected ON
Off	Option Cycle / Select AO button is detected OFF

Test Menu 22/01/2024 15:23:57

Game Settings	Steering	1515
Bookkeeping Settings	Steering Min	273
Credit Settings	Steering Max	3264
Input Settings	Steering Center	1828
Output Settings	Gas Pedal	3415
Clock Settings	Gas Pedal Min	3420
Network Settings	Gas Pedal Max	3711
Language Settings	Gas Pedal Dead Zone	5
Reset All Settings	Brake	1415
	Brake Min	1428
	Brake Max	1529
	Brake Dead Zone	5
	Throttle	1983
	Throttle Min	2000
	Throttle Max	3888
	Throttle Limited	Off
	Throttle Dead Zone	0
	Stop	On
	SeatBelt	Off
	Down	Off
	Option Cycle / Select	Off
	Test / Exit	Off
	Back / Service	Off
	Start	Off
	View	Off
	Camera	Not Connected
	IO Board	Connected (1P v00.84-01.13)
	Motion Board	Connected (1P v01.09-00.07)
	Reset Settings	
	Back	

Disk Image Ver. 0.0.0
Game Ver. 0.3.8-rc.1

4.4.4-22 Test / Exit

Under **Test / Exit**, whether **Test / Exit** AO Button is set ON/OFF will be detected.

Test / Exit	Description
On	Test / Exit AO button is detected ON
Off	Test / Exit AO button is detected OFF

Test Menu 22/01/2024 15:23:59

Game Settings	Steering	1528
Bookkeeping Settings	Steering Min	273
Credit Settings	Steering Max	3264
Input Settings	Steering Center	1828
Output Settings	Gas Pedal	3437
Clock Settings	Gas Pedal Min	3420
Network Settings	Gas Pedal Max	3711
Language Settings	Gas Pedal Dead Zone	5
Reset All Settings	Brake	1428
	Brake Min	1428
	Brake Max	1529
	Brake Dead Zone	5
	Throttle	1984
	Throttle Min	2000
	Throttle Max	3888
	Throttle Limited	Off
	Throttle Dead Zone	0
	Stop	On
	SeatBelt	Off
	Down	Off
	Option Cycle / Select	Off
	Test / Exit	Off
	Back / Service	Off
	Start	Off
	View	Off
	Camera	Not Connected
	IO Board	Connected (1P v00.84-01.13)
	Motion Board	Connected (1P v01.09-00.07)
	Reset Settings	
	Back	

Disk Image Ver. 0.0.0
Game Ver. 0.3.8-rc.1

4.4.4-23 Back / Service

Under **Back / Service**, whether **Back / Service** AO Button is set ON/OFF will be detected.

Back / Service	Description
On	Back/ Service AO button is detected ON
Off	Back/ Service AO button is detected OFF

Test Menu 22/01/2024 15:24:00

Game Settings	Steering	1520
Bookkeeping Settings	Steering Min	273
Credit Settings	Steering Max	3264
Input Settings	Steering Center	1828
Output Settings	Gas Pedal	3415
Clock Settings	Gas Pedal Min	3420
Network Settings	Gas Pedal Max	3711
Language Settings	Gas Pedal Dead Zone	5
Reset All Settings	Brake	1409
	Brake Min	1428
	Brake Max	1529
	Brake Dead Zone	5
	Throttle	1987
	Throttle Min	2000
	Throttle Max	3888
	Throttle Limited	Off
	Throttle Dead Zone	0
	Stop	On
	SeatBelt	Off
	Down	Off
	Option Cycle / Select	Off
	Test / Exit	Off
	Back / Service	Off
	Start	Off
	View	Off
	Camera	Not Connected
	IO Board	Connected (1P v00.84-01.13)
	Motion Board	Connected (1P v01.09-00.07)
	Reset Settings	
	Back	

Disk Image Ver. 0.0.0
Game Ver. 0.3.8-rc.1

4.4.4-24 Start

Under **Start**, whether **Start** AO Button is set ON/OFF will be detected.

Start	Description
On	Start AO button is detected ON
Off	Start AO button is detected OFF

Test Menu 22/01/2024 15:24:02

Game Settings	Steering	1536
Bookkeeping Settings	Steering Min	273
Credit Settings	Steering Max	3264
Input Settings	Steering Center	1828
Output Settings	Gas Pedal	3437
Clock Settings	Gas Pedal Min	3420
Network Settings	Gas Pedal Max	3711
Language Settings	Gas Pedal Dead Zone	5
Reset All Settings	Brake	1434
	Brake Min	1428
	Brake Max	1529
	Brake Dead Zone	5
	Throttle	1984
	Throttle Min	2000
	Throttle Max	3888
	Throttle Limited	Off
	Throttle Dead Zone	0
	Stop	On
	SeatBelt	Off
	Down	Off
	Option Cycle / Select	Off
	Test / Exit	Off
	Back / Service	Off
	Start	Off
	View	Off
	Camera	Not Connected
	IO Board	Connected (1P v00.84-01.13)
	Motion Board	Connected (1P v01.09-00.07)
	Reset Settings	
	Back	

Disk Image Ver. 0.0.0
Game Ver. 0.3.8-rc.1

4.4.4-25 View

Under **View**, whether **View** AO Button is set ON/OFF will be detected.

View	Description
On	View AO button is detected ON
Off	View AO button is detected OFF

Test Menu 22/01/2024 15:24:04

Game Settings	Steering	1522
Bookkeeping Settings	Steering Min	273
Credit Settings	Steering Max	3264
Input Settings	Steering Center	1828
Output Settings	Gas Pedal	3438
Clock Settings	Gas Pedal Min	3420
Network Settings	Gas Pedal Max	3711
Language Settings	Gas Pedal Dead Zone	5
Reset All Settings	Brake	1427
	Brake Min	1428
	Brake Max	1529
	Brake Dead Zone	5
	Throttle	1983
	Throttle Min	2000
	Throttle Max	3888
	Throttle Limited	Off
	Throttle Dead Zone	0
	Stop	On
	SeatBelt	Off
	Down	Off
	Option Cycle / Select	Off
	Test / Exit	Off
	Back / Service	Off
	Start	Off
	View	Off
	Camera	Not Connected
	IO Board	Connected (1P v00.84-01.13)
	Motion Board	Connected (1P v01.09-00.07)
	Reset Settings	
	Back	

Disk Image Ver. 0.0.0
Game Ver. 0.3.8-rc.1

4.4.4-26 Camera

Under **Camera**, Camera status will be detected automatically and shown here.

Camera	Description
Detected	Camera is detected
Not Connected	Camera is not detected

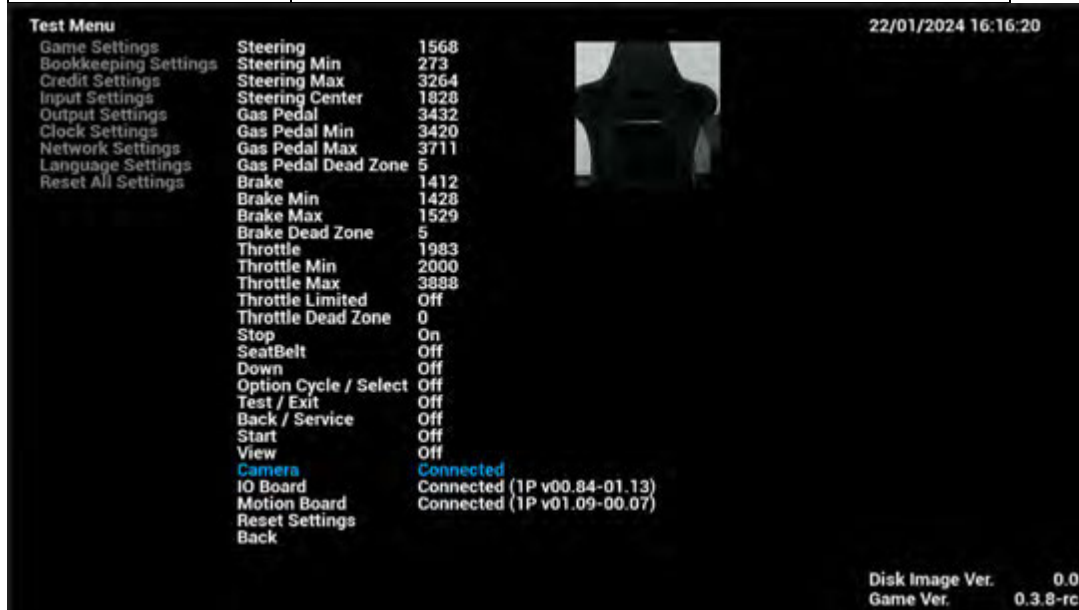

4.4.4-27 IO Board

Under **IO Board**, IO Board status will be detected automatically and shown here.

IO Board	Description
Connected	IO Board is detected and connected
Not Connected	IO Board is not connected

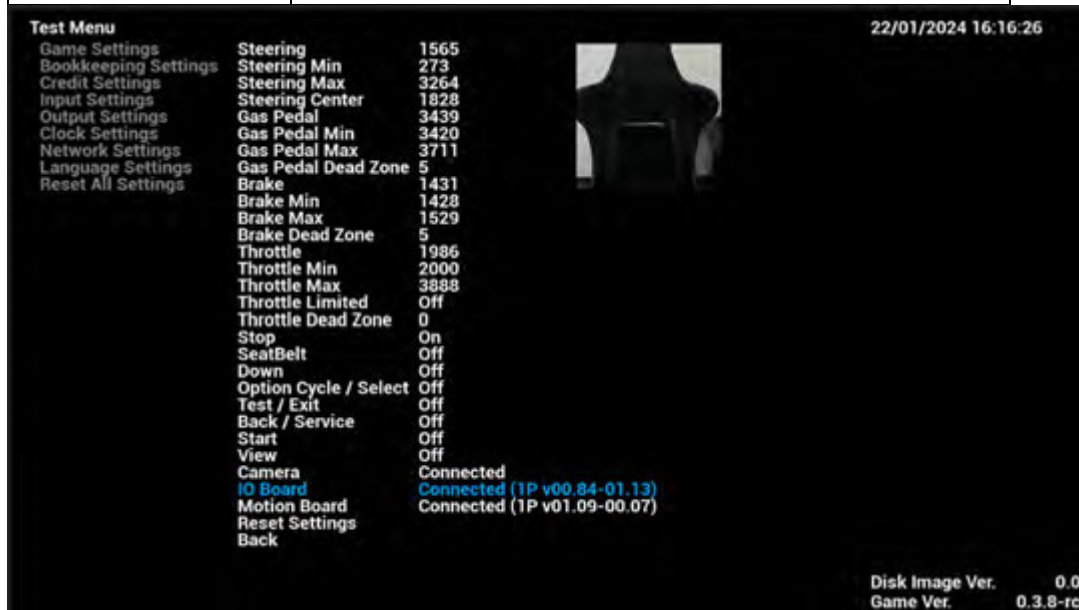

4.4.4-28 Motion Board

Under **Motion Board**, Motion Board status will be detected automatically and shown here.

Motion Board	Description
Connected	Motion Board is detected and connected
Not Connected	Motion Board is not connected

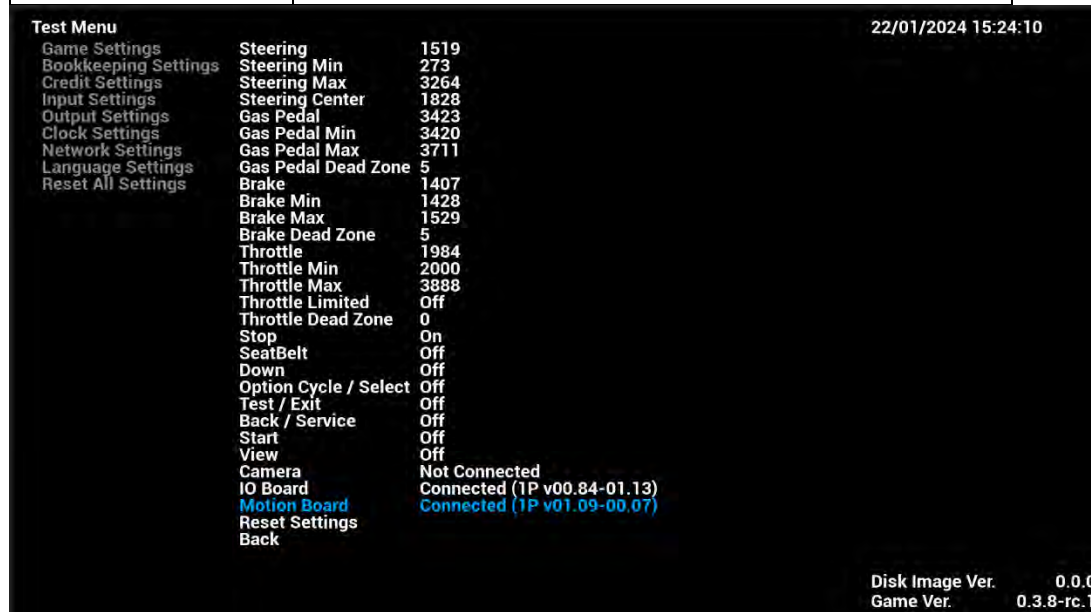

The screenshot displays a 'Test Menu' interface with a dark background and white text. The menu is organized into two columns. The left column lists various settings, and the right column shows their corresponding values. At the top right, the date and time '22/01/2024 15:24:10' are displayed. At the bottom right, the 'Disk Image Ver.' is '0.0.0' and the 'Game Ver.' is '0.3.8-rc.1'. The 'Motion Board' status is highlighted in blue text and is shown as 'Connected (IP v01.09-00.07)'.

Test Menu		22/01/2024 15:24:10
Game Settings	Steering	1519
Bookkeeping Settings	Steering Min	273
Credit Settings	Steering Max	3264
Input Settings	Steering Center	1828
Output Settings	Gas Pedal	3423
Clock Settings	Gas Pedal Min	3420
Network Settings	Gas Pedal Max	3711
Language Settings	Gas Pedal Dead Zone	5
Reset All Settings	Brake	1407
	Brake Min	1428
	Brake Max	1529
	Brake Dead Zone	5
	Throttle	1984
	Throttle Min	2000
	Throttle Max	3888
	Throttle Limited	Off
	Throttle Dead Zone	0
	Stop	On
	SeatBelt	Off
	Down	Off
	Option Cycle / Select	Off
	Test / Exit	Off
	Back / Service	Off
	Start	Off
	View	Off
	Camera	Not Connected
	IO Board	Connected (IP v00.84-01.13)
	Motion Board	Connected (IP v01.09-00.07)
	Reset Settings	
	Back	

Disk Image Ver. 0.0.0
Game Ver. 0.3.8-rc.1

4.4.4-29 Reset Settings

By complying **Reset Settings**, all sub-menu items of **Input Settings** will be reset to default settings.

4.4.5 Output Settings

Under **Output Settings**, settings related to game output can be adjusted here.

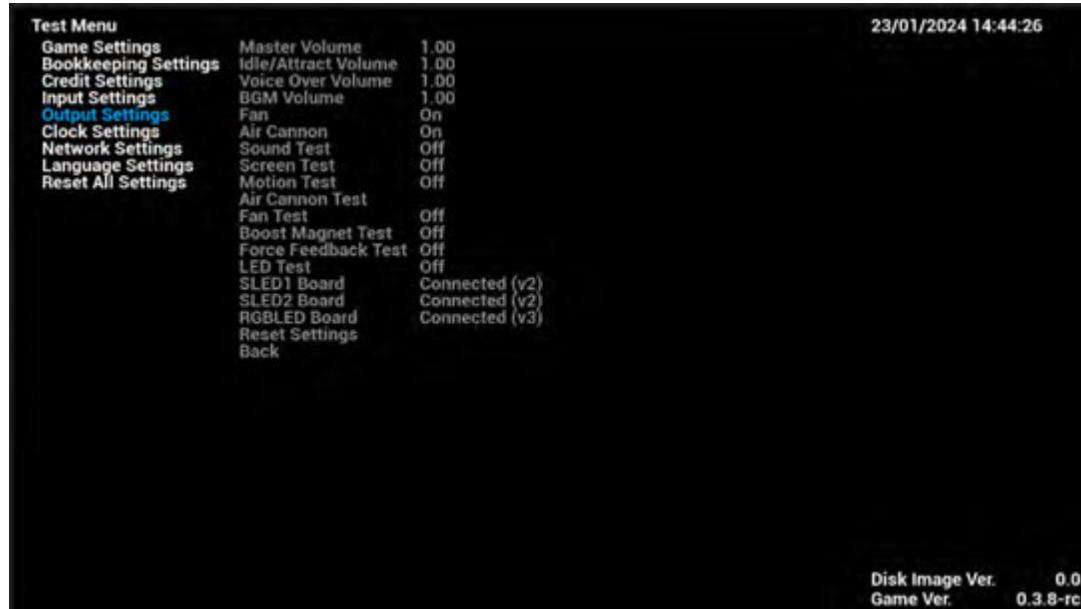

4.4.5-1 Master Volume

Under **Master Volume**, the inputs of the volume can be adjusted between **0.1-2**.

Master Volume	The overall volume
Idle/Attract Volume	The volume during attract
Voice Over Volume	The volume of Voice Over Volume in game
BGM Volume	The volume of the background music in game

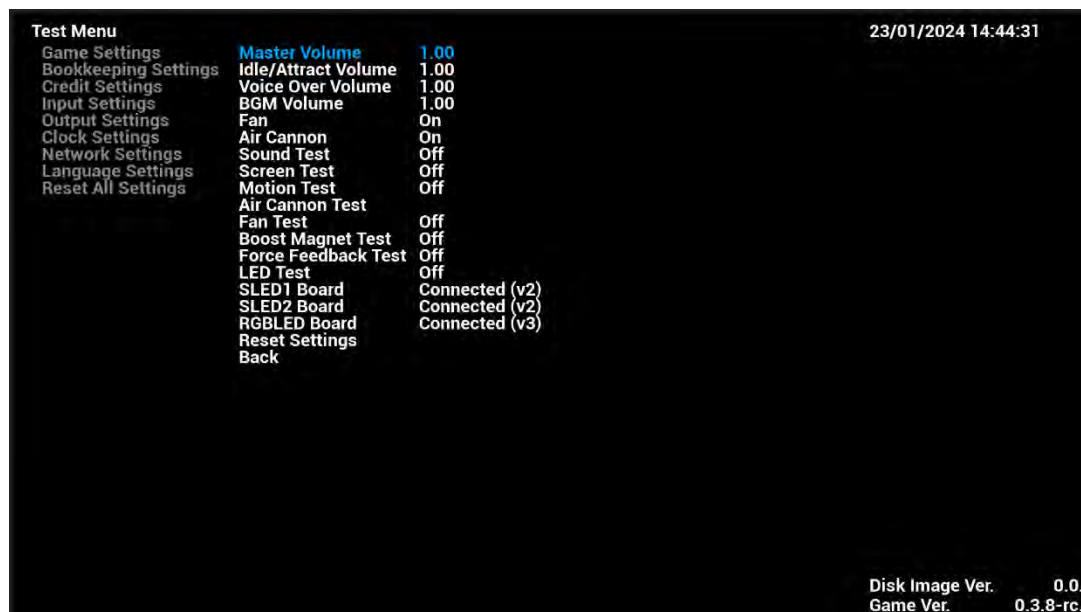

4.4.5-2 Idle/Attract Volume

Under **Idle/Attract Volume**, the inputs of the volume can be adjusted between **0.1-2**.

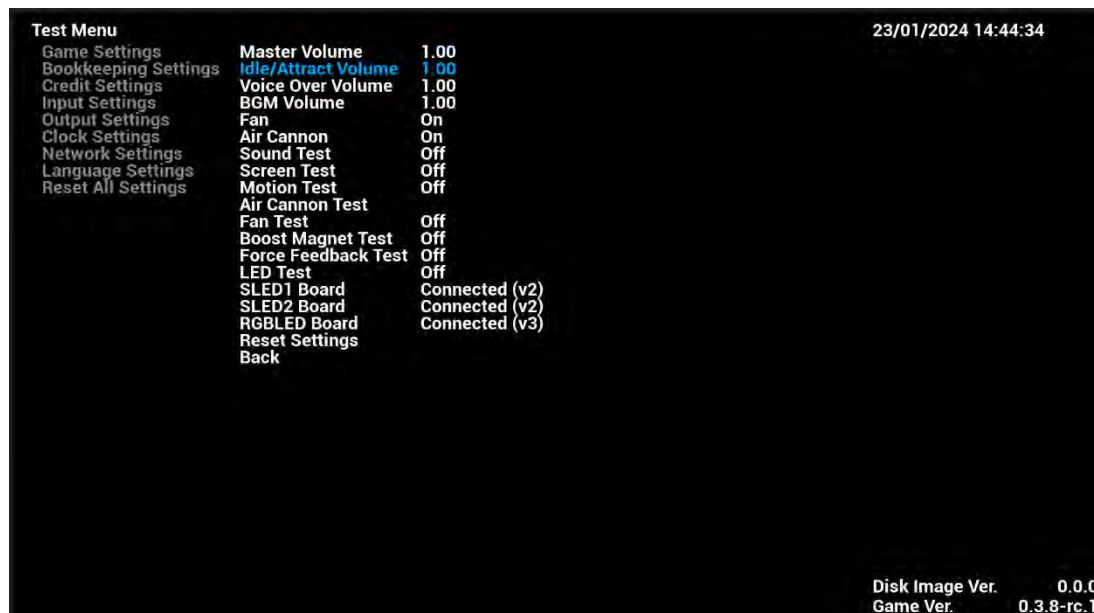

4.4.5-3-Voice Over Volume

Under **Voice Over Volume**, the inputs of the VO volume can be adjusted between **0.1-2**.

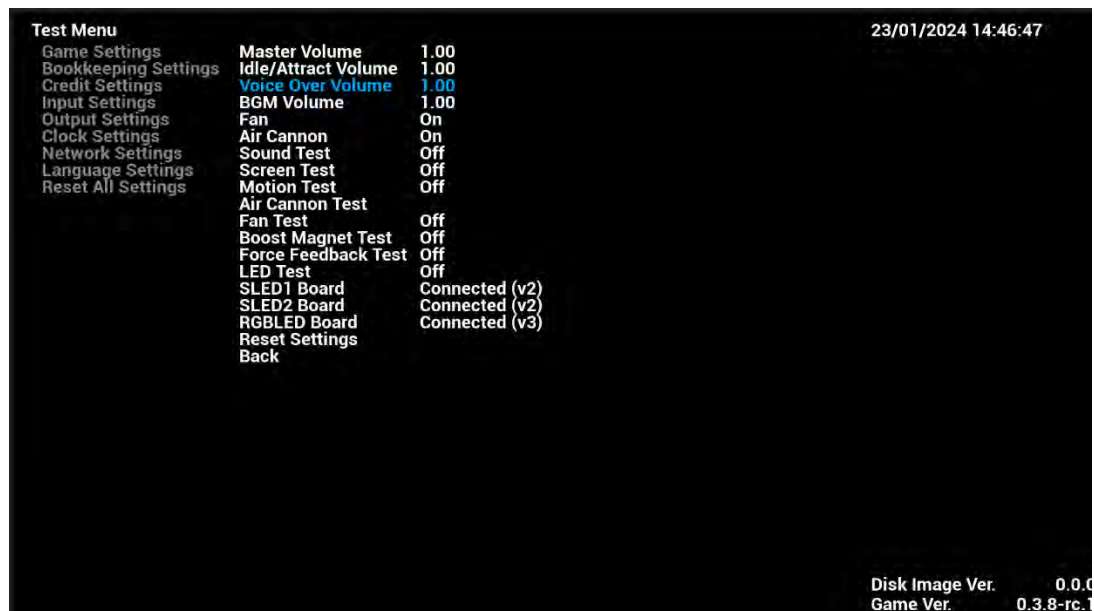

4.4.5-4-BGM Volume

Under **BGM Volume**, the inputs of the VO volume can be adjusted between **0.1-2**.

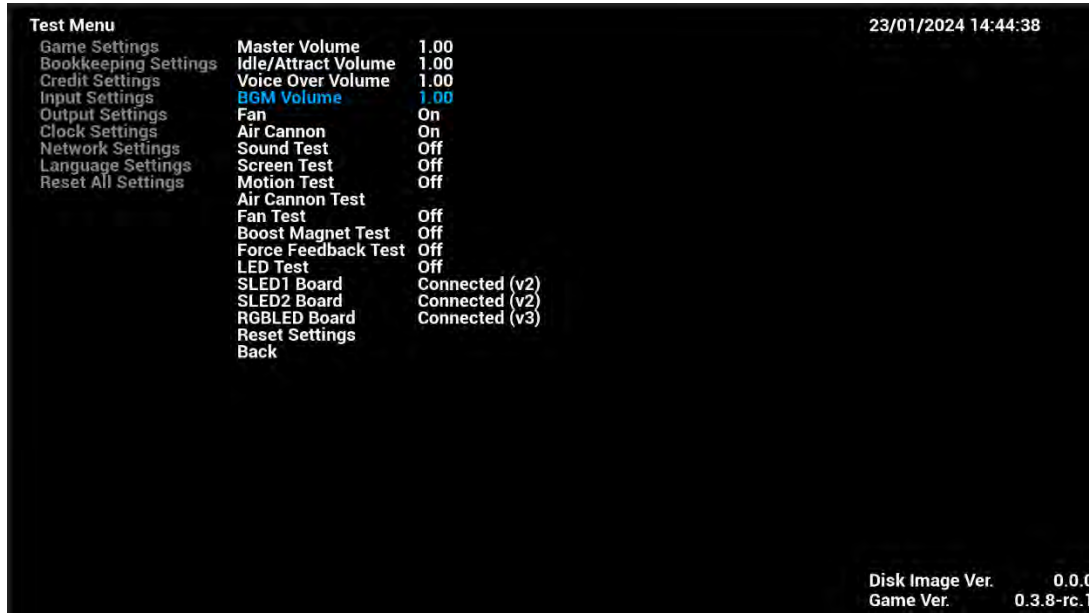

4.4.5-5 Fan

Under **Fan**, Fan (two sides of steering wheel) can be set ON/OFF.

Fan	Description
On	Fan is set ON
Off	Fan is set OFF

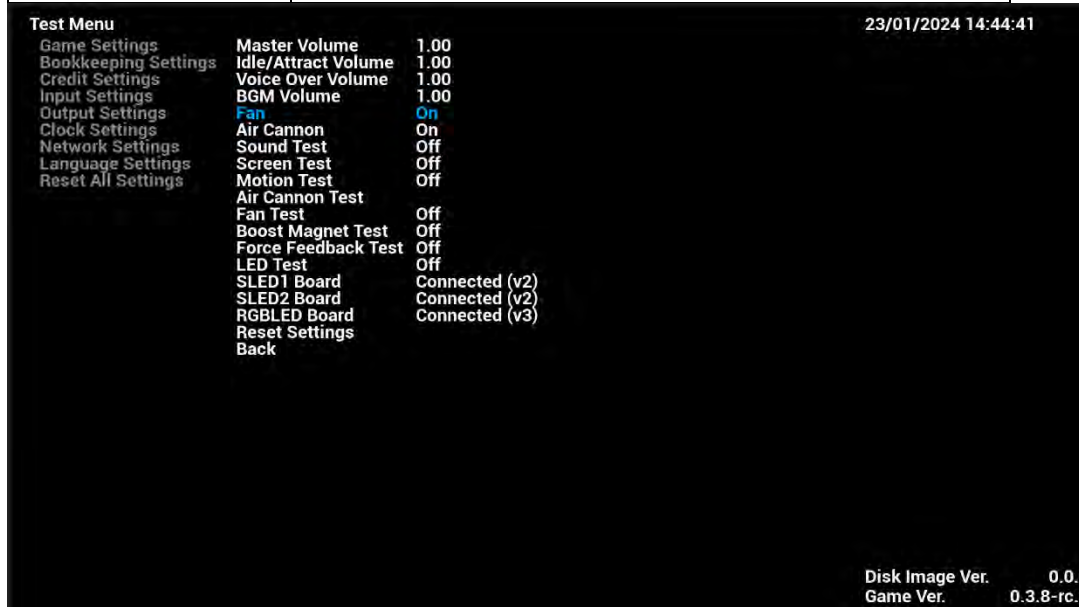

4.4.5-6 Air Cannon

Under **Air Cannon**, Air Cannon (center of car dashboard) can be set ON/OFF.

Air Cannon	Description
On	Air Cannon is set ON
Off	Air Cannon is set OFF

The screenshot shows the 'Test Menu' interface. On the left, a list of settings categories is visible: Game Settings, Bookkeeping Settings, Credit Settings, Input Settings, Output Settings, Clock Settings, Network Settings, Language Settings, and Reset All Settings. The main area displays various system settings and their current status:

- Master Volume: 1.00
- Idle/Attract Volume: 1.00
- Voice Over Volume: 1.00
- BGM Volume: 1.00
- Fan: On
- Air Cannon: On**
- Sound Test: Off
- Screen Test: Off
- Motion Test: Off
- Air Cannon Test: Off
- Fan Test: Off
- Boost Magnet Test: Off
- Force Feedback Test: Off
- LED Test: Off
- SLED1 Board: Connected (v2)
- SLED2 Board: Connected (v2)
- RGBLED Board: Connected (v3)
- Reset Settings
- Back

The top right corner shows the date and time: 23/01/2024 14:44:43. The bottom right corner shows version information: Disk Image Ver. 0.0.0 and Game Ver. 0.3.8-rc.1.

4.4.5-7 Sound Test

Under **Sound Test**, all speakers of the cabinet will be tested here.

Sound Test	Description
Off	Sound is turned off
Front Left side	Front Left side of the speaker is on for testing
Front Right side	Front Right side of the speaker is on for testing
Back Left side	Back Left side of the speaker is on for testing
Back Right side	Back Right side of the speaker is on for testing
Sub	Bass speaker is on for testing

The screenshot shows the 'Test Menu' interface with 'Sound Test' selected. The main area displays the following settings:

- Master Volume: 1.00
- Idle/Attract Volume: 1.00
- Voice Over Volume: 1.00
- BGM Volume: 1.00
- Fan: On
- Air Cannon: On
- Sound Test: Off**
- Screen Test: Off
- Motion Test: Off
- Air Cannon Test: Off
- Fan Test: Off
- Boost Magnet Test: Off
- Force Feedback Test: Off
- LED Test: Off
- SLED1 Board: Connected (v2)
- SLED2 Board: Connected (v2)
- RGBLED Board: Connected (v3)
- Reset Settings
- Back

The top right corner shows the date and time: 23/01/2024 14:44:45. The bottom right corner shows version information: Disk Image Ver. 0.0.0 and Game Ver. 0.3.8-rc.1.

4.4.5-8 Screen Test

Under **Screen Test**, colors of screen will be tested here.

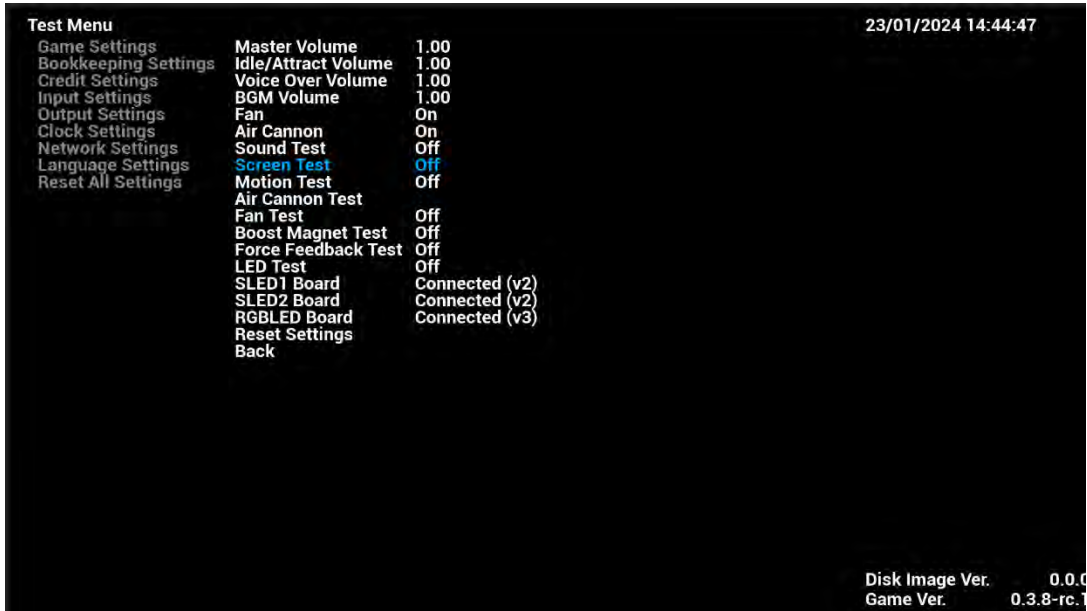

There are three images to test the colors of screen:

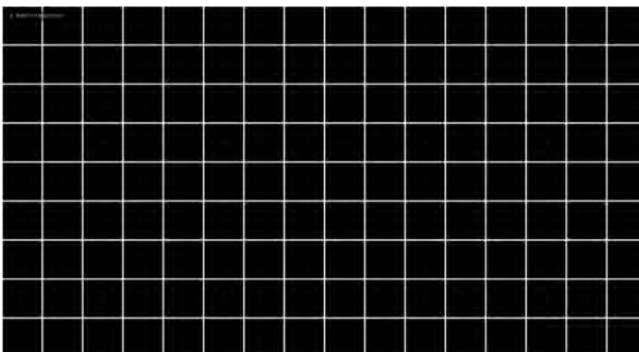
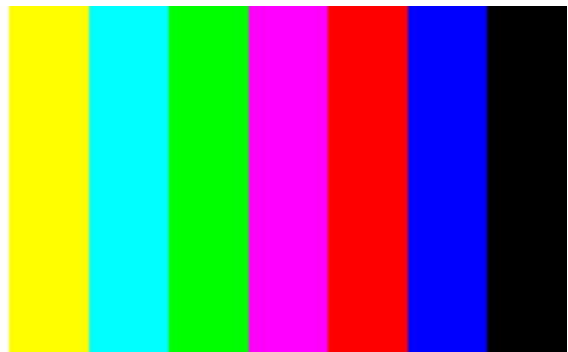

4.4.5-9 Motion Test

Under **Motion Test**, motion of the cabinet will be tested here.

Motion Test	Description
Off	Motion is turned off
Front Left side	Front Left side motion moving UP is on for testing
Front Right side	Front Right side motion moving UP is on for testing
Rear Left side	Back Left side motion moving UP is on for testing
Rear Right side	Back Right side motion moving UP is on for testing

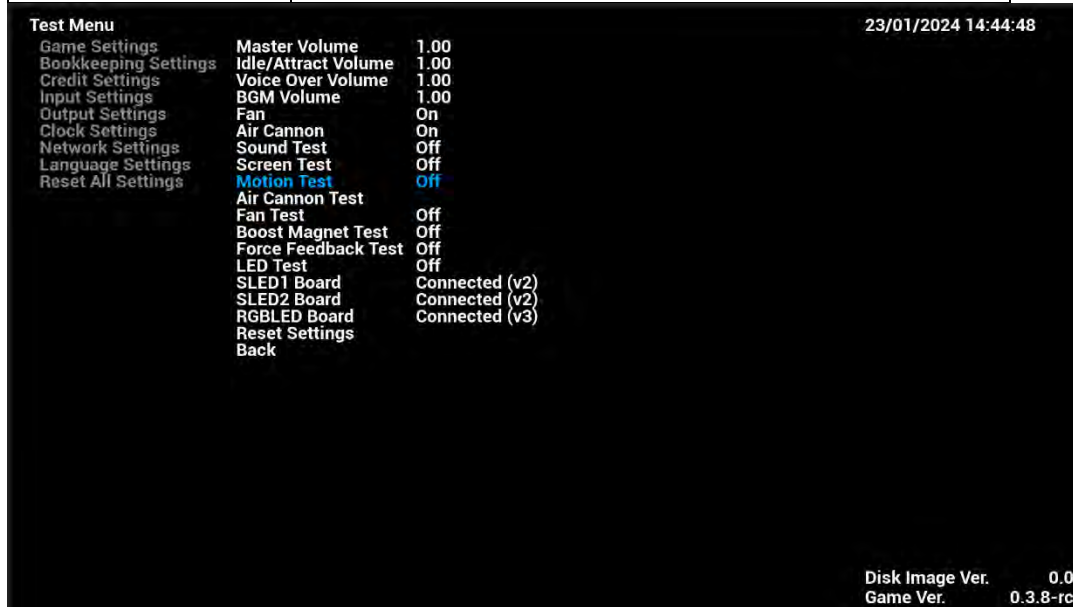

4.4.5-10 Air Cannon Test

Under **Air Cannon Test**, air cannon (center of car dashboard) of the cabinet will be tested here.

Air Cannon Test	Description
Off	Air Cannon is turned off
On	Air Cannon is on for testing

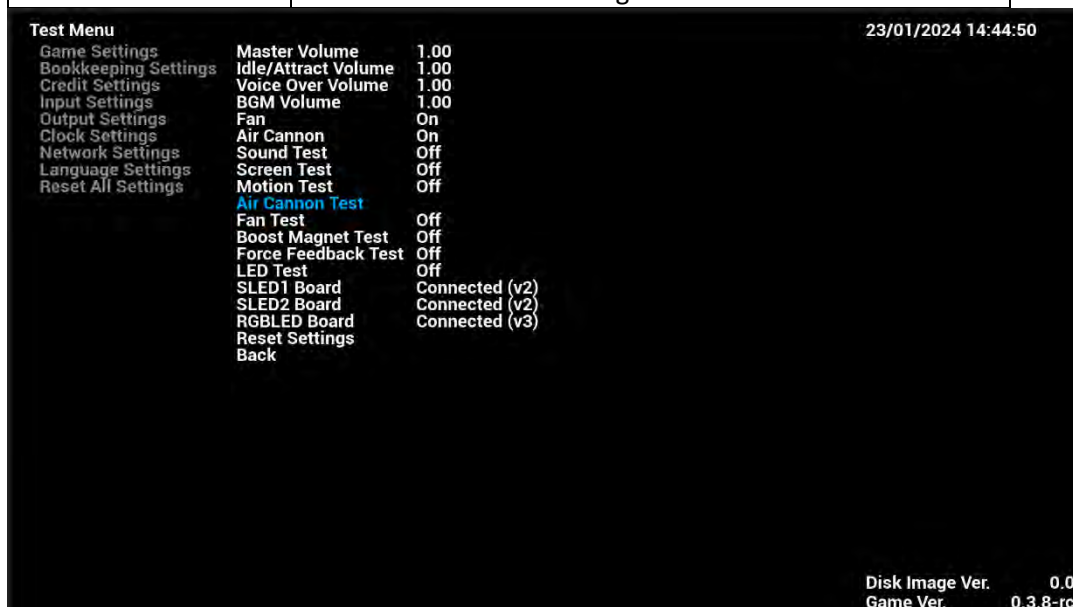

4.4.5-11 Fan Test

Under **Fan Test**, fan (two sides of steering wheel) of the cabinet will be tested here.

Fan Test	Description
Off	Fan is turned off
On	Fan is on for testing

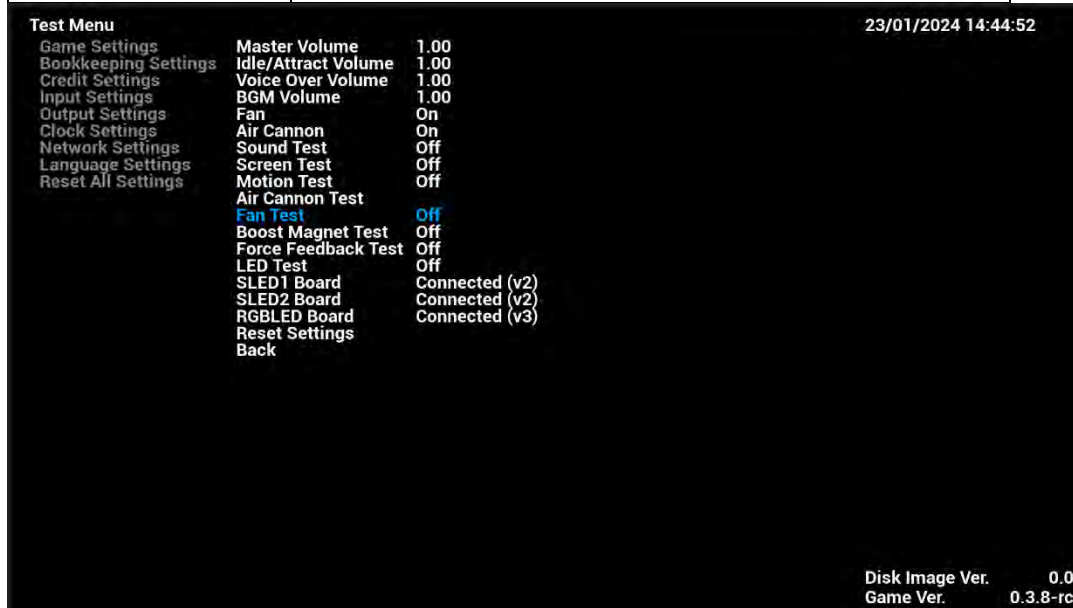

4.4.5-12 Boost Magnet Test

Under **Boost Magnet Test**, magnet (BOOST Bar) of the cabinet will be tested here.

Note: Turn “ON” and push the boost handle up to ensure it is held in position by the electromagnet.

Boost Magnet Test	Description	Instruction
Off	Boost Magnet is turned off	Push the boost handle to the top position and release, the boost handle will automatically drop to the lowest position.
On	Boost Magnet is on for testing	Push the boost handle to the top position and then release it, the boost handle will be attracted to the top position.

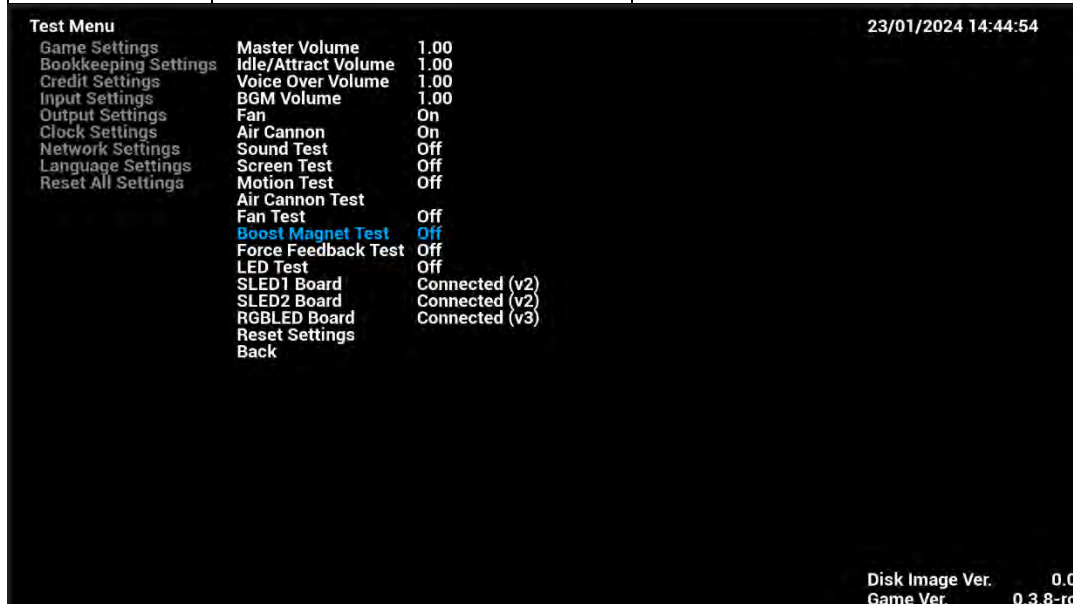

4.4.5-13 Force Feedback Test

Under **Force Feedback Test**, the steering wheel force feedback of the cabinet will be tested here.

Force Feedback Test	Description
Off	Steering wheel force feedback is turned off
Left	Left side Steering wheel force feedback is on for testing
Right	Right side Steering wheel force feedback is on for testing

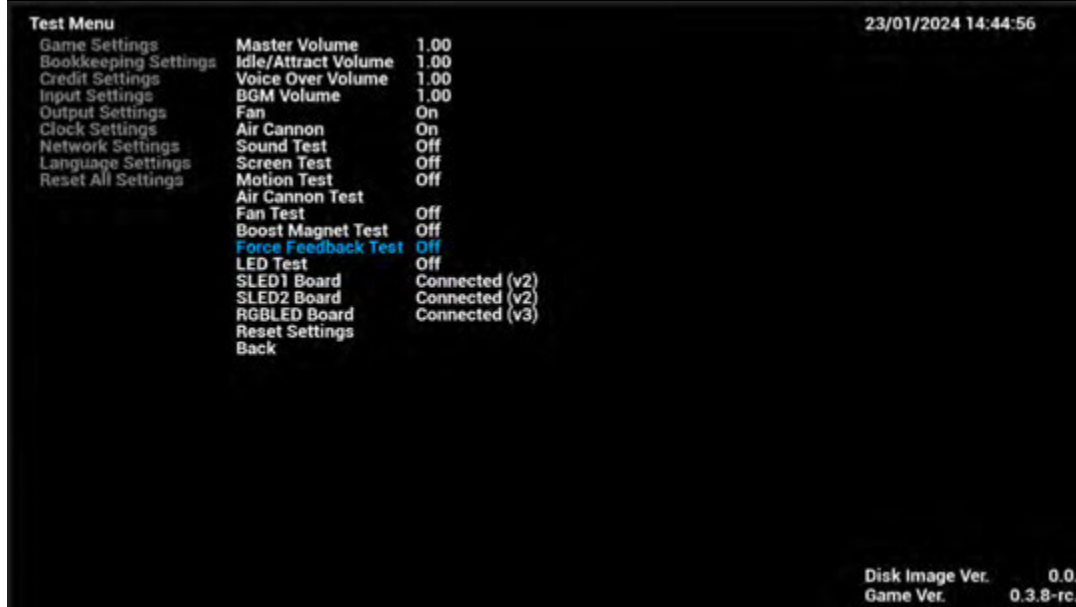

4.4.5-14 LED Test

Under **LED Test**, all lights of the cabinet will be tested here.

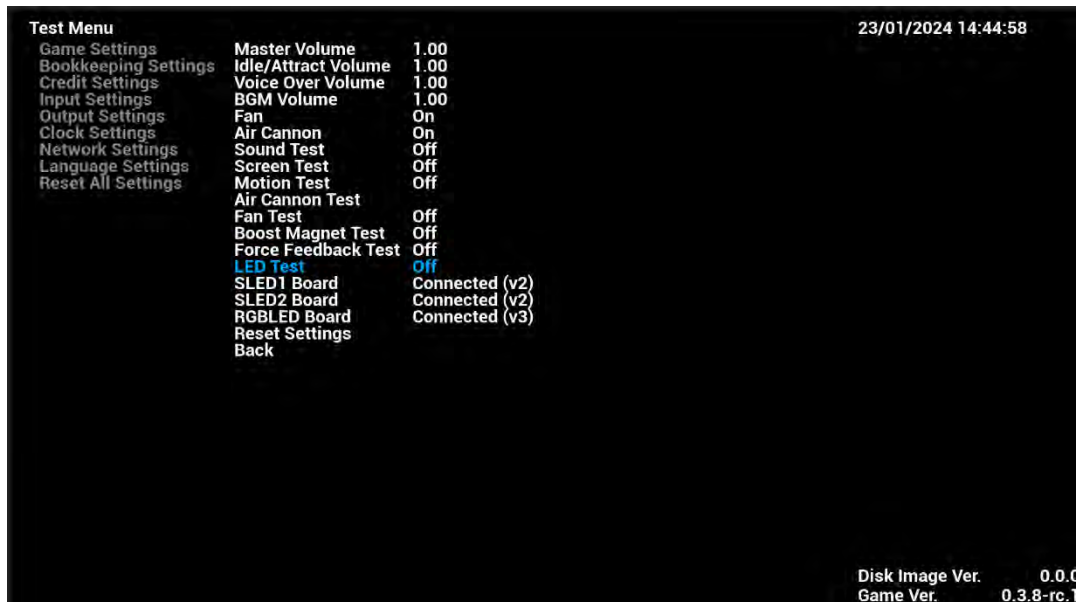

NOTE: Logo LED tests are for the non-Matrix LED header versions of this game. If your game has the Matrix LCD header, the Logo tests will not work so disregard.

Light Test	Description
Off	All light tests are turned off
Logo Left Red	The logo left LED will be red and others will be off
Logo Left Green	The logo left LED will be green and others will be off
Logo Left Blue	The logo left LED will be blue and others will be off
Logo Left White	The logo left LED will be white and others will be off
Logo Right Red	The logo right LED will be red and others will be off
Logo Right Green	The logo right LED will be green and others will be off
Logo Right Blue	The logo right LED will be blue and others will be off
Logo Right White	The logo right LED will be white and others will be off
Side Left Red	The side left LED will be red and others will be off
Side Left Green	The side left LED will be green and others will be off
Side Left Blue	The side left LED will be blue and others will be off
Side Left White	The side left LED will be white and others will be off
Side Right Red	The side right LED will be red and others will be off
Side Right Green	The side right LED will be green and others will be off
Side Right Blue	The side right LED will be blue and others will be off
Side Right White	The side right LED will be white and others will be off
Wheel Left Red	The wheel left LED will be red and others will be off
Wheel Left Green	The wheel left LED will be green and others will be off
Wheel Left Blue	The wheel left LED will be blue and others will be off
Wheel Left White	The wheel left LED will be white and others will be off
Wheel Right Red	The wheel right LED will be red and others will be off
Wheel Right Green	The wheel right LED will be green and others will be off
Wheel Right Blue	The wheel right LED will be blue and others will be off
Wheel Right White	The wheel right LED will be white and others will be off
Brake Red	The brake LED will be red and others will be off

Brake Green	The brake LED will be green and others will be off
Brake Blue	The brake LED will be blue and others will be off
Brake White	The brake LED will be white and others will be off
Speaker Red	The speaker LED will be red and others will be off
Speaker Green	The speaker LED will be green and others will be off
Speaker Blue	The speaker LED will be blue and others will be off
Speaker White	The speaker LED will be white and others will be off
Gear Red	The gear LED will be red and others will be off
Gear Green	The gear LED will be green and others will be off
Gear Blue	The gear LED will be blue and others will be off
Gear White	The gear LED will be white and others will be off
Steering Red	The steering LED will be red and others will be off
Steering Green	The steering LED will be green and others will be off
Steering Blue	The steering LED will be blue and others will be off
Steering White	The steering LED will be white and others will be off
Spoiler Red	The spoiler LED will be red and others will be off
Spoiler Green	The spoiler LED will be green and others will be off
Spoiler Blue	The spoiler LED will be blue and others will be off
Spoiler White	The spoiler LED will be white and others will be off
Tail Pipe Red	The tail pipe LED will be red and others will be off
Tail Pipe Green	The tail pipe LED will be green and others will be off
Tail Pipe Blue	The tail pipe LED will be blue and others will be off
Tail Pipe White	The tail pipe LED will be white and others will be off
Cabinet ID Red	The cabinet id LED will be red and others will be off
Cabinet ID Green	The cabinet id LED will be green and others will be off
Cabinet ID Blue	The cabinet id LED will be blue and others will be off

Cabinet ID White	The cabinet id LED will be white and others will be off
Seat Back Red	The seat back LED will be red and others will be off
Seat Back Green	The seat back LED will be green and others will be off
Seat Back Blue	The seat back LED will be blue and others will be off
Seat Back White	The seat back LED will be white and others will be off

4.4.5-15 SLED1 Board

Under **SLED1 Board**, status of SLED1 board will be detected and shown here.

SLED1 Board	Description
Connected	SLED1 board is detected and connected
Not Connected	No SLED1 board is detected and connected



4.4.5-16 SLED2 Board

Under **SLED2 Board**, status of SLED2 board will be detected and shown here.

SLED2 Board	Description
Connected	SLED2 board is detected and connected
Not Connected	No SLED2 board is detected and connected

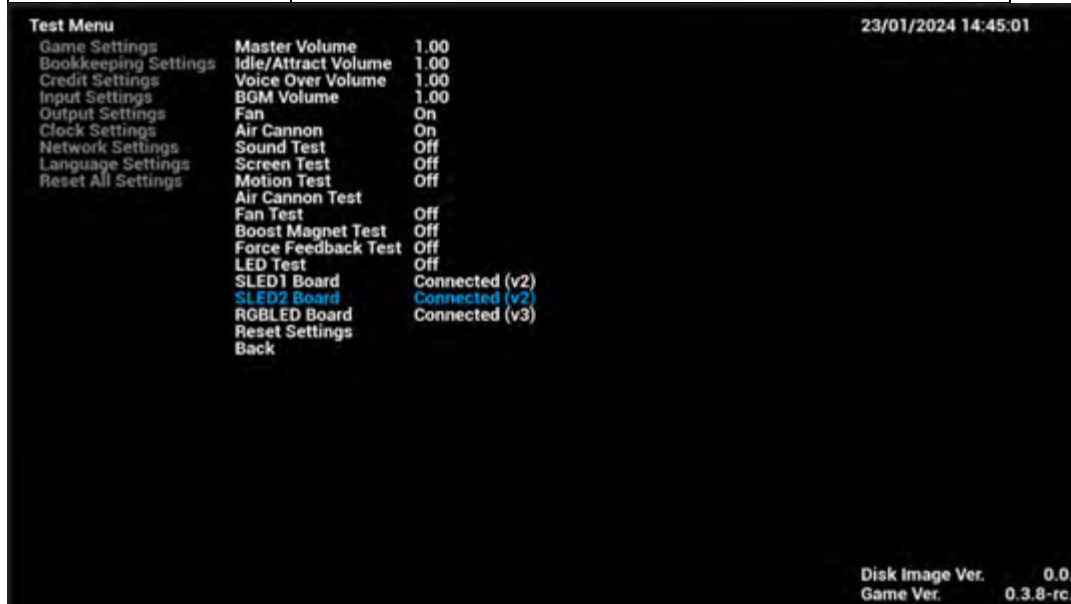

4.4.5-17 RGBLED Board

Under **RGBLED Board**, status of RGBLED board will be detected and shown here.

RGBLED Board	Description
Connected	RGBLED board is detected and connected
Not Connected	No RGBLED board is detected and connected

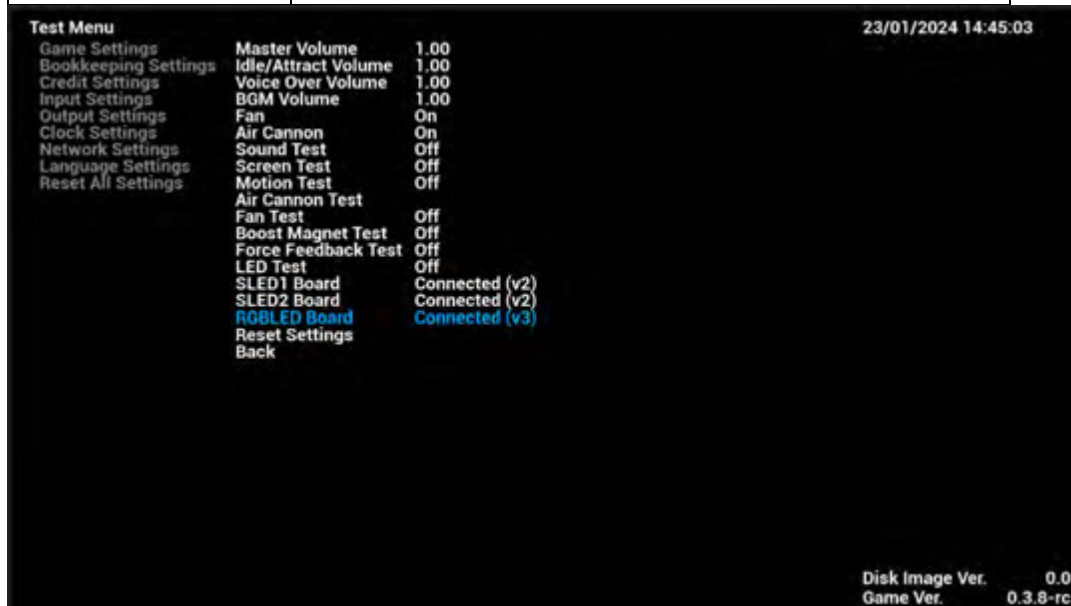

4.4.5-18 Reset Settings

By complying **Reset Settings**, all sub-menu items of **Output Settings** will be reset to default settings.

4.4.6 Clock Settings

Under **Clock Settings**, settings related to date and time of the cabinet can be adjusted here.

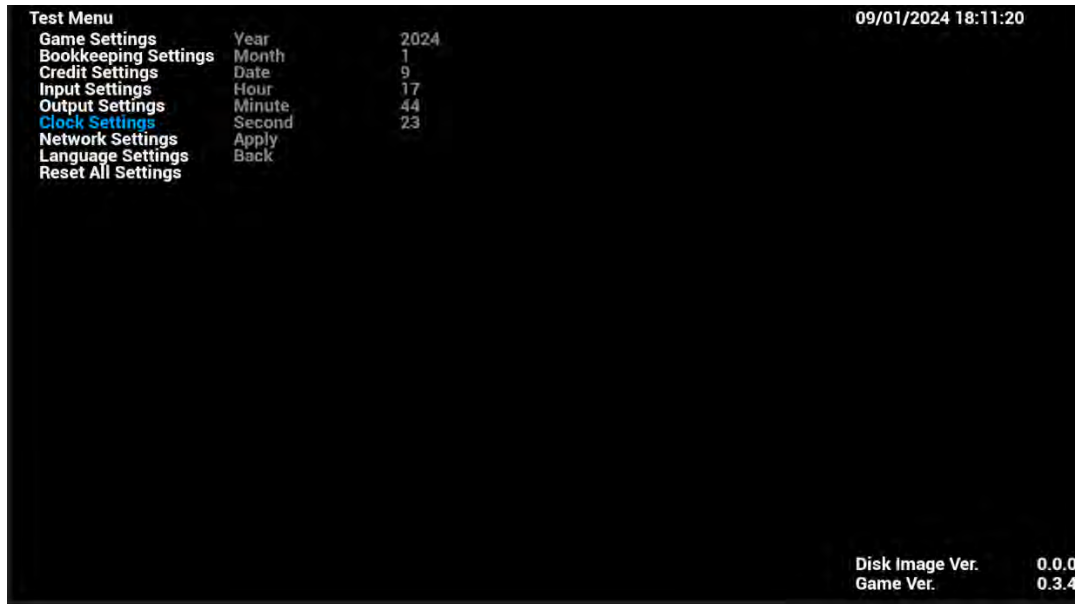

4.4.6-1 Year

Under **Year**, year can be adjusted.

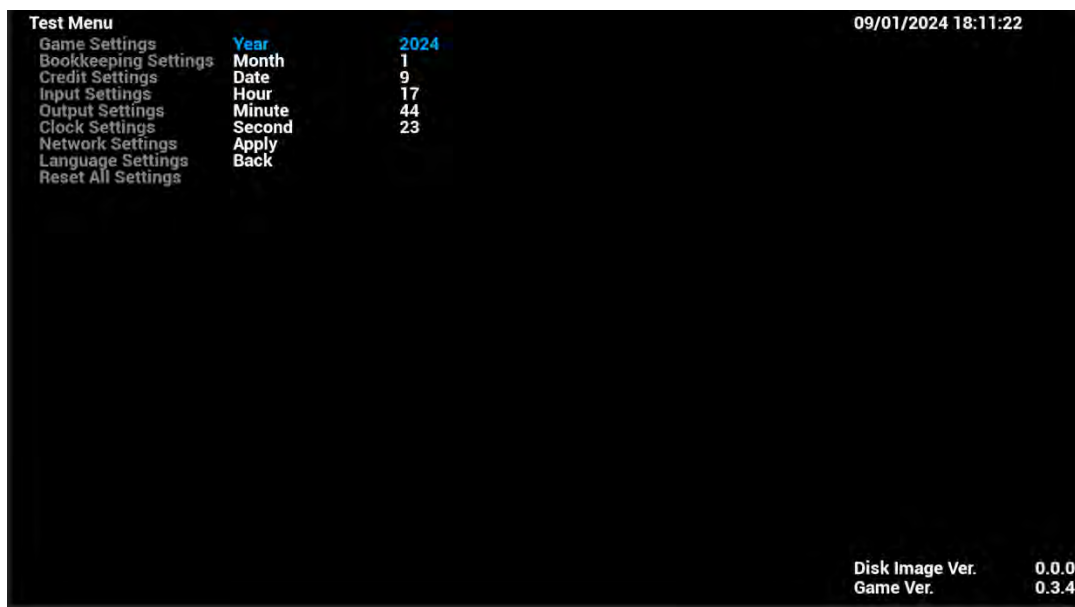

4.4.6-2 Month

Under **Month**, month of year can be adjusted.

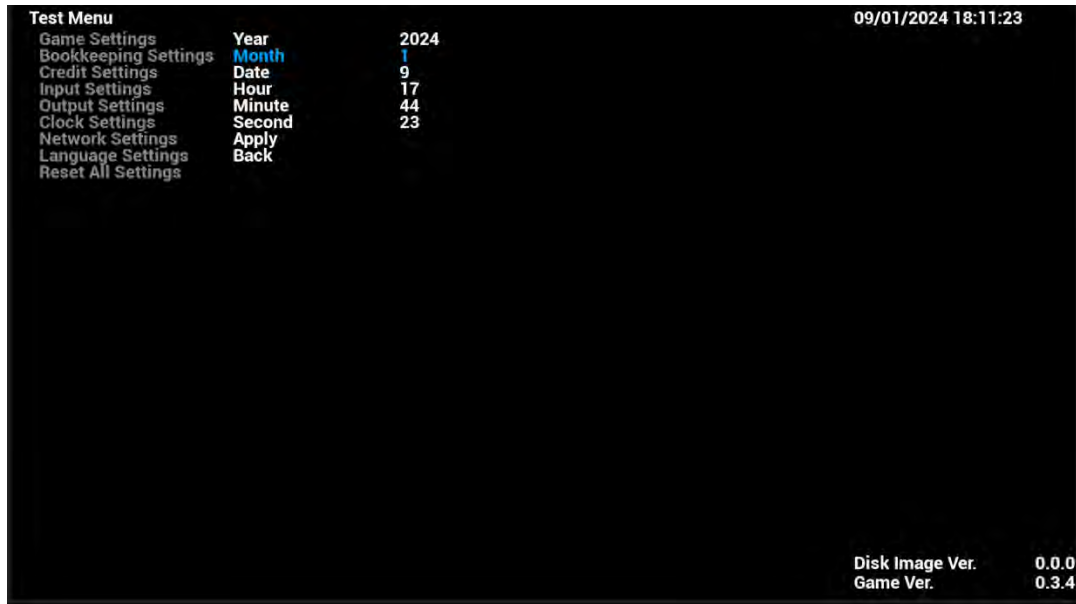

4.4.6-3 Day

Under **Day**, date of month can be adjusted.



4.4.6-4 Hour

Under **Hour**, hour of day can be adjusted.



4.4.6-5 Minute

Under **Minute**, minute of hour can be adjusted.

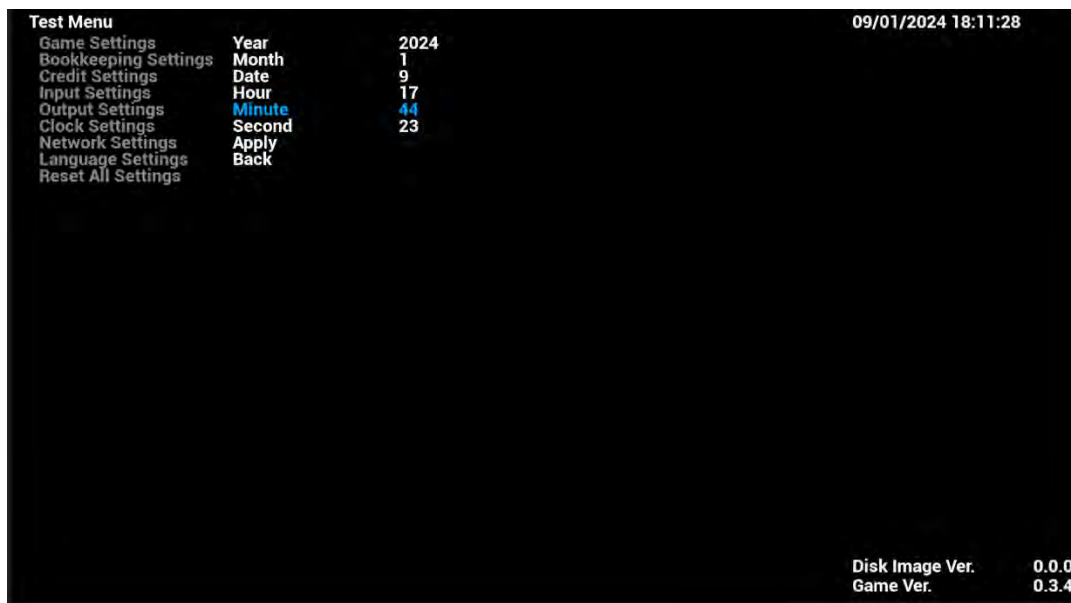

4.4.6-6 Second

Under **Second**, second of minute can be adjusted.



4.4.6-7 Apply

By complying **Apply**, all changes made in above sub-menu items of **Clock Settings** will be applied.



4.4.7 Network Settings

Under **Network Settings**, settings related to network of the cabinet can be adjusted here.

Test Menu 09/01/2024 18:12:26

Game Settings	Network Status	No Link
Bookkeeping Settings	Machine IP	192.168.166.19
Credit Settings	Group ID	1
Input Settings	Cabinet ID	1
Output Settings	IP Mode	Auto
Clock Settings	Range 1	192
Network Settings	Range 2	168
Language Settings	Range 3	166
Reset All Settings	ConfirmIP	
	Other Machine IP	---
	Other Group ID	0
	Other Cabinet ID	0
	Reset Settings	
	Back	

Disk Image Ver. 0.0.0
Game Ver. 0.3.4

4.4.7-1 Network Status

Under **Network Status**, number of linked cabinets (maximum of 3) can be adjusted.

Network Status	Description
Linked 1/2/3 Cabs	Linked with 1/2/3 (max. of 3 cabinets) other cabinet(s)
No Link	No other cabinet is detected and linked

Test Menu 09/01/2024 18:12:31

Game Settings	Network Status	No Link
Bookkeeping Settings	Machine IP	192.168.166.19
Credit Settings	Group ID	1
Input Settings	Cabinet ID	1
Output Settings	IP Mode	Auto
Clock Settings	Range 1	192
Network Settings	Range 2	168
Language Settings	Range 3	166
Reset All Settings	ConfirmIP	
	Other Machine IP	---
	Other Group ID	0
	Other Cabinet ID	0
	Reset Settings	
	Back	

Disk Image Ver. 0.0.0
Game Ver. 0.3.4

4.4.7-2 Machine IP

Under **Machine IP**, IP of cabinet will be detected and shown.

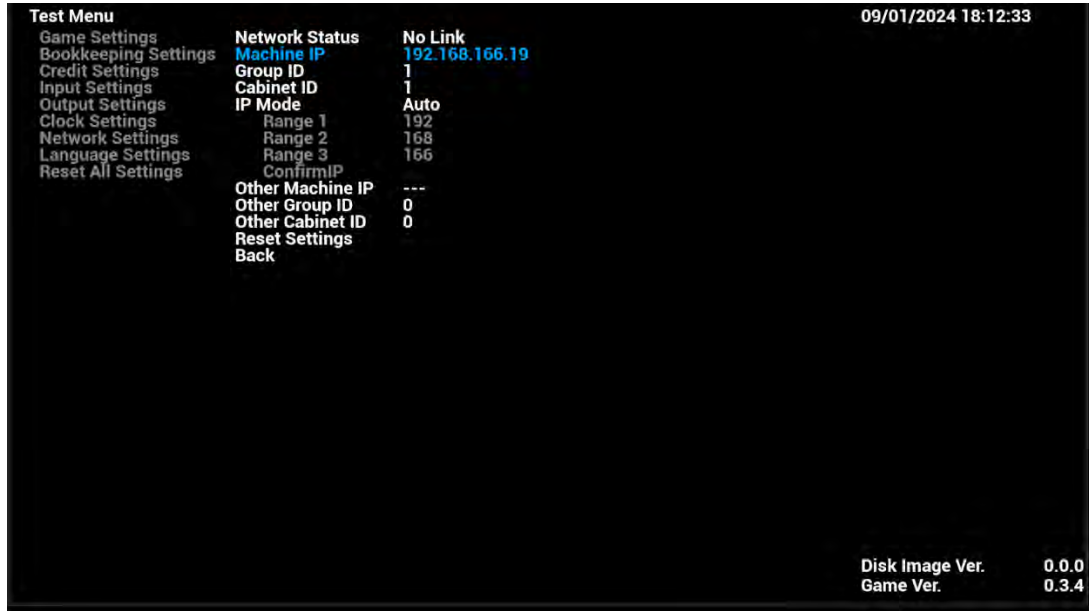

4.4.7-3 Group ID

Under **Group ID**, it refers to the group to which the current machine belongs, numbered 1-8. Two or more machines need to be in the same group to activate linked gameplay.

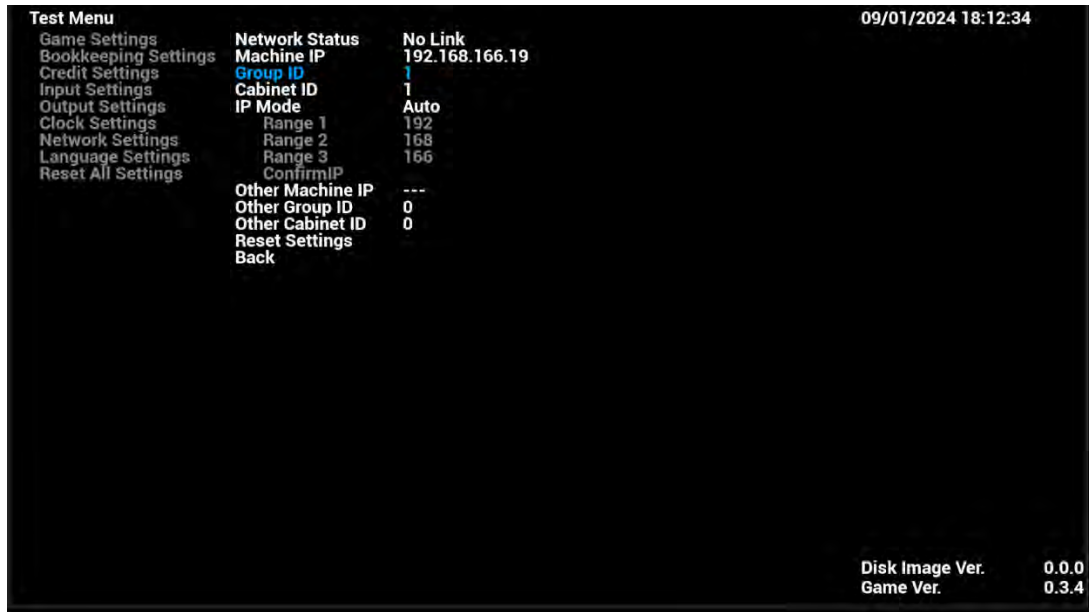

4.4.7-4 Cabinet ID

Under **Cabinet ID**, ID of cabinet from 1-4 can be adjusted. Number cannot be repeated between linked cabinets.

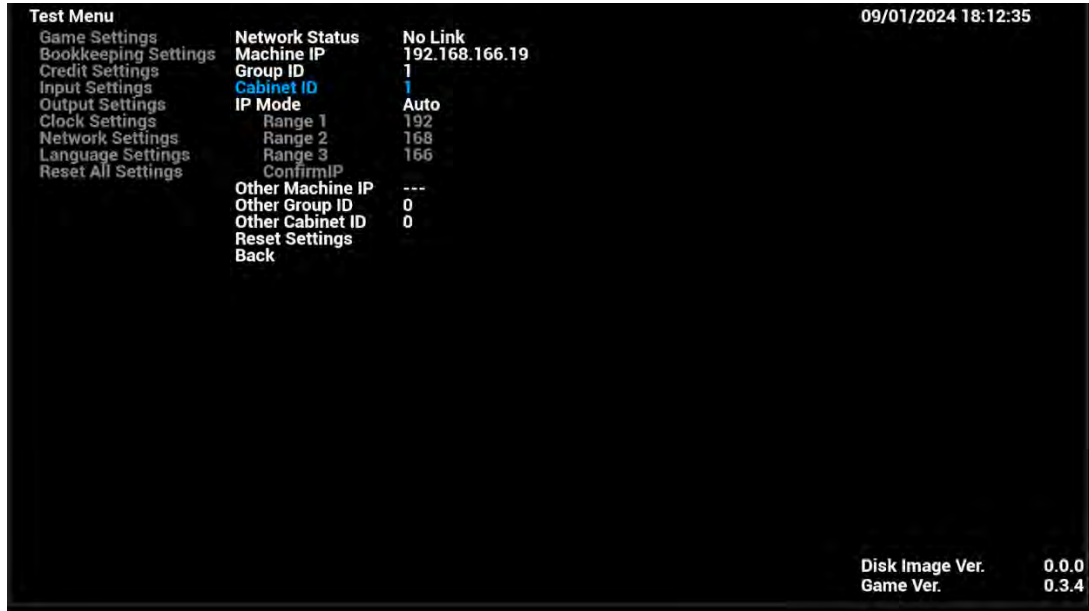

4.4.7-5 IP Mode

Under **IP Mode**, IP of the cabinet can be set and obtained.

IP Mode	Description
Auto	IP will be obtained automatically
Manual	IP can be configured by Range 1, 2 and 3 (Please select [Confirm IP] to apply changes described in 3. Linking and Networking)

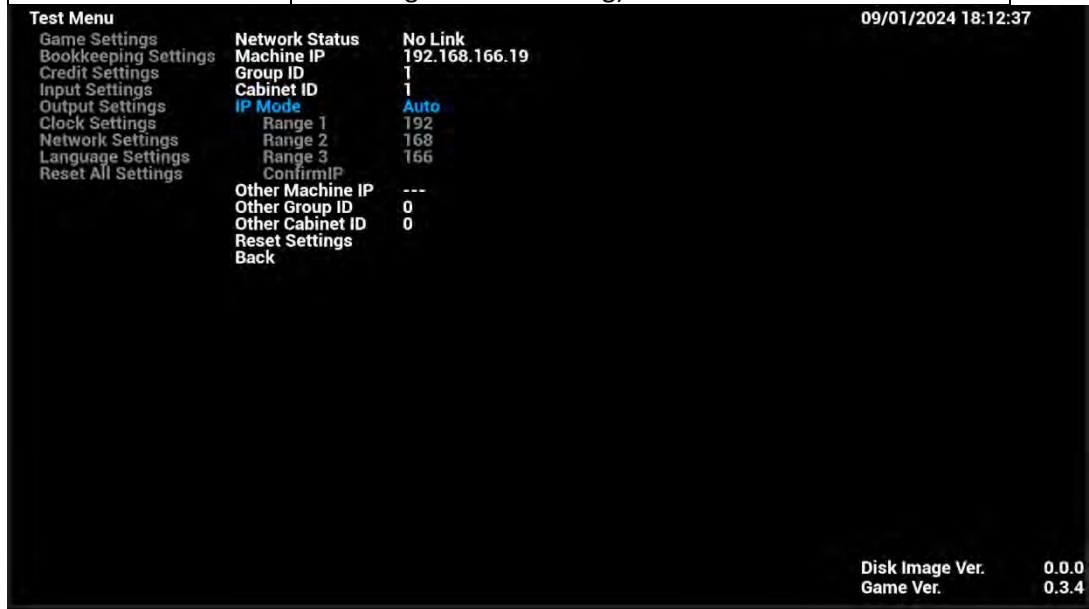

4.4.7-6 Other Machine IP

Under **Other Machine IP**, it will show the IPs of other linked machines, and can view the IPs of other machines by switching.

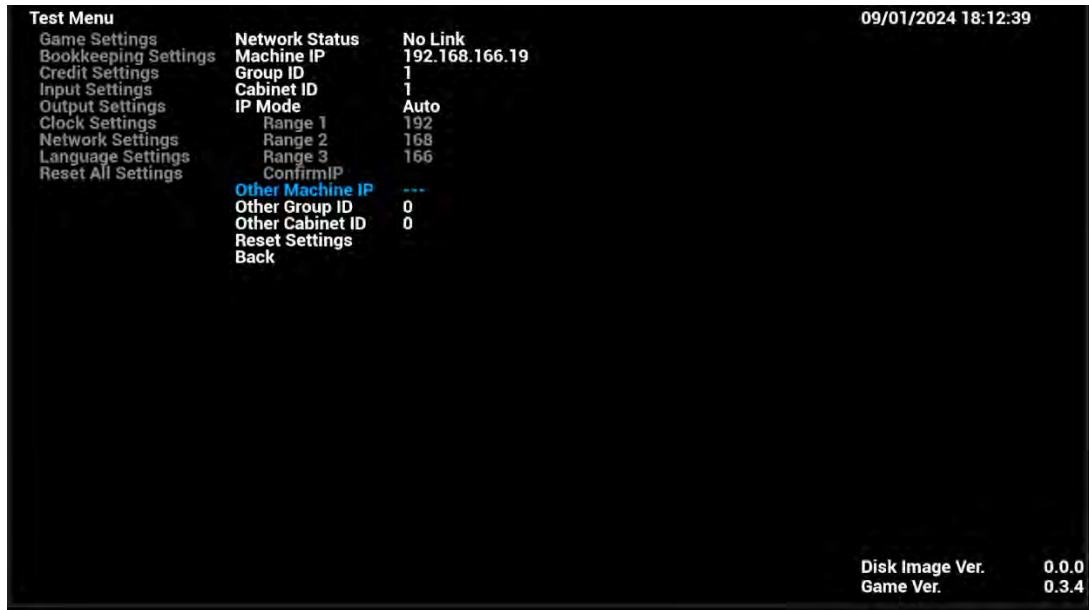

4.4.7-7 Other Group ID

Under **Other Group ID**, it allows to modify the Group ID of other machine(s) based on the corresponding of other Machine(s).



4.4.7-8 Other Cabinet ID

Under **Other Cabinet ID**, it allows to modify the Cabinet ID of other machine(s) based on the corresponding of other Machine(s).

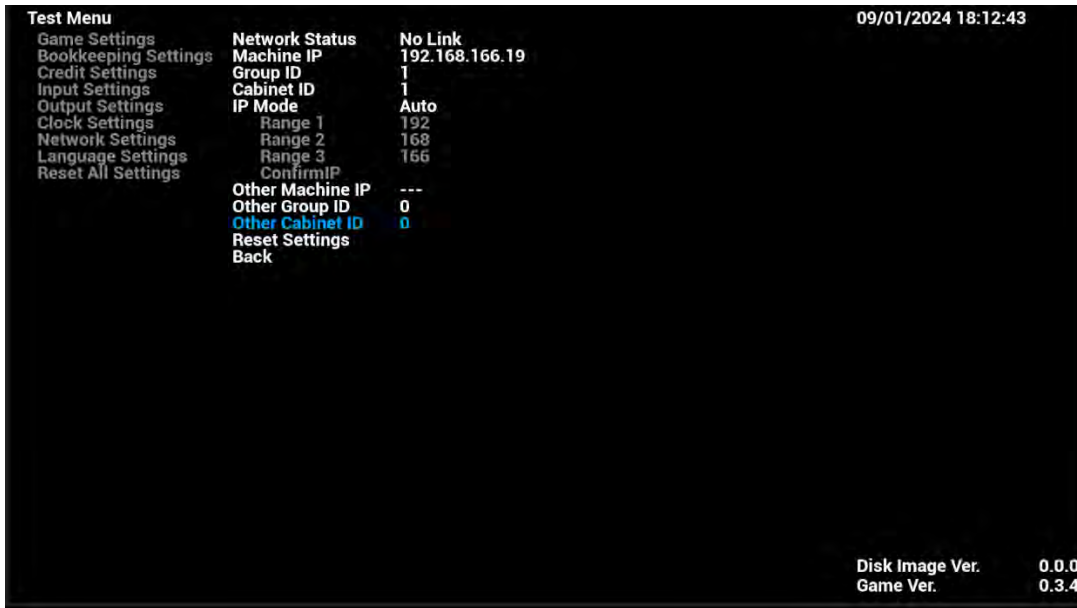

4.4.7-9 Reset Network Settings

By complying **Reset Network Settings**, all sub-menu items of **Network Settings** will be set to default settings.

4.4.8 Language Settings

Under **Language Settings**, language of the cabinet can be adjusted here.



4.4.8- 1 Language

Under **Language**, language of the cabinet can be adjusted.

Language	
English	Spanish
French	Italian
German	Turkish
Portuguese	

4.4.8- 2 Reset Language Settings

By complying **Reset Language Settings**, language of cabinet will be reset to default language - English.

4.4.9 Reset All Settings

By complying **Reset All Settings**, all settings in **AO Test Menu** will be reset to factory default settings.

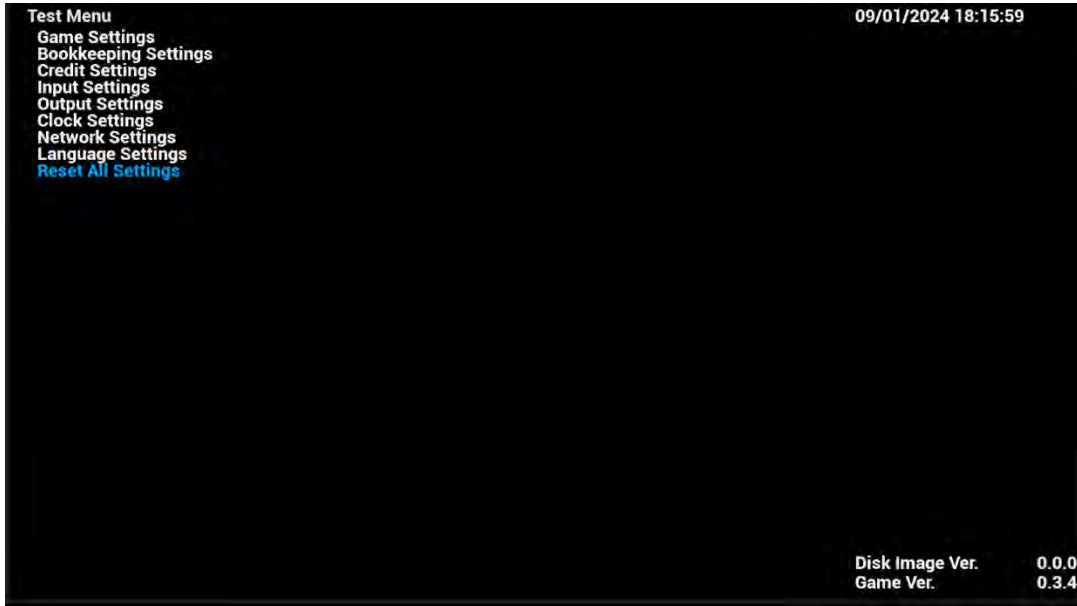

5. Game Errors and Troubleshooting

5.1 – I/O Connection Error

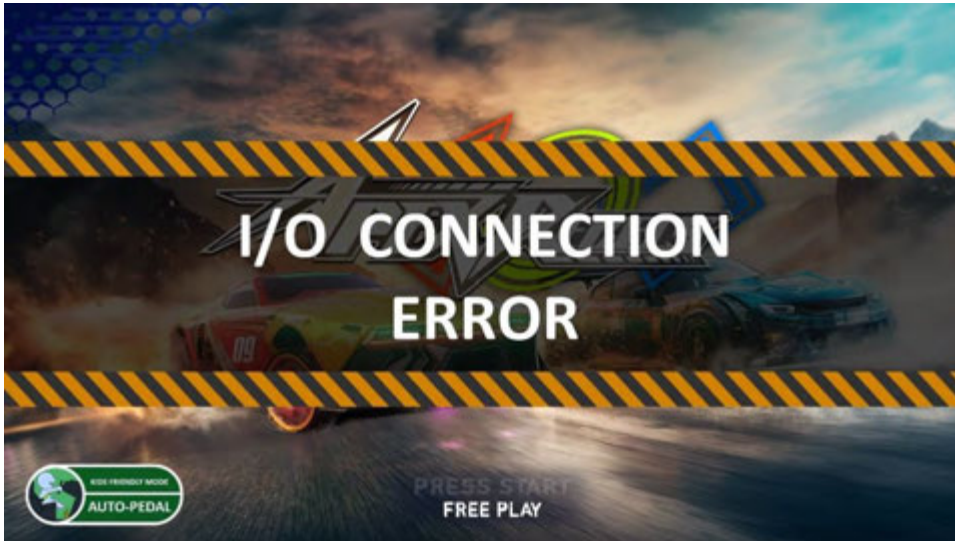

Cause	Troubleshooting
When I/O Board is not detected or connected.	<ol style="list-style-type: none">1) Check if the LED on the IO board is flashing if not, go to 2) if yes, go to 4)2) Check if the LED on the IO board is always ON. If yes, there is something wrong with the IO board. If not, please go to 3)3) Please check if the 12V supply is OK4) Check if the LED on the IO board is flashing more than 2 times per second If yes, please check if the USB cable is connecting well from the PC to the IO board; If not, there might be something wrong with the game.

5.2 – Motion Connection Error



Cause	Troubleshooting
When Motion Board is not detected or connected.	<ol style="list-style-type: none">1) Check if the LED on the Motion board is flashing if not, go to 2) if yes, go to 4)2) Check if the LED on the Motion board is always ON. If yes, there is something wrong with the Motion board. If not, please go to 3)3) Please check if the 12V supply is OK4) Check if the LED on the IO board is flashing more than 2 times per second If yes, please check if the USB cable is connecting well from the PC to the Motion board; If not, there might be something wrong with the game.

5.3 – Cabinet ID Error



Cause	Troubleshooting
Each cabinet must be set for its unique ID when linked. When Cabinet ID is repeated in setting, error will occur.	Choose an unique Cabinet ID for each linked machine. Enter operator menu, in Network Settings, reset Cabinet ID.

6. Maintenance and Service

6.1 Maintenance and Service

WARNING

- When working with the product, be sure to turn the power off. Working with the power on may cause an electric shock or short circuit.
- Be careful not to damage the wires. Damaged wires may cause an electric shock, short circuit or present a risk of fire.
- Do not touch any parts that are not specified in these directions. Touching unspecified locations may lead to electric shock or cause short circuits.
- This work should be performed by site maintenance personnel or other skilled professionals. Work performed by non-technical personnel can cause a severe accident such as an electric shock.
- Exercise due caution in performing soldering procedures. If soldering iron is handled carelessly, there could be fires or burns.
- Proceed very carefully when heating thermal contraction tube. Careless operations can result in fires or burns.

CAUTION

- When fastening plastic parts, be careful not to tighten screws and nuts excessively. Otherwise parts may be damaged, resulting in injuries from fragments, etc.
- Be careful not to get hand or finger caught when removing or attaching the parts.
- Disconnection and connection of connectors will be performed within the narrow cabinet space. Take due care not to scratch or otherwise injure yourself.
- Take care when carrying the removed Control Units. Such heavy lifting carries a risk of injury to back or shoulders.

STOP IMPORTANT

- After the volume has been replaced, be sure to set the volume value on the test mode calibration screen and the input test screen and check variations in the volume value
- After adjusting or replacing a microswitch, always check ON/OFF of the switch on the input test screen of the test mode
- Handle parts inside the Control Unit very carefully. Be especially careful to avoid damage, deformation or loss of these parts. If any one of these parts is lost or defective, it can result in damages and/or faulty operations

If the operability of the Control Unit is unsatisfactory, or if settings on the test mode calibration screen are ineffective, the problem could be a defective mechanism, displacement of the position where volume or microswitch has been fastened or malfunctioning of volume or microswitch.

Carry out the following procedure to replace Control Unit or microswitch. Also be sure to grease the mechanical components of the Control Unit once every 3 months.

6.2 Parts Replacement

6.2.1 Replacement of Camera

Step 1: Remove the top plate of monitor & glass.

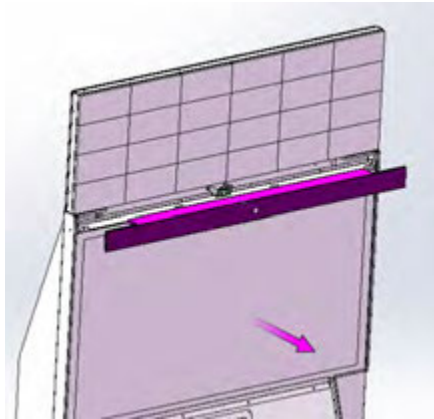

Step 2: Remove the camera ASSY (attention the wire).

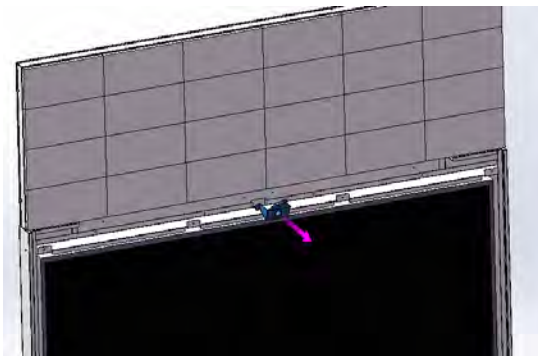

Step 3: Replace with new camera, repeat above steps in reverse order.

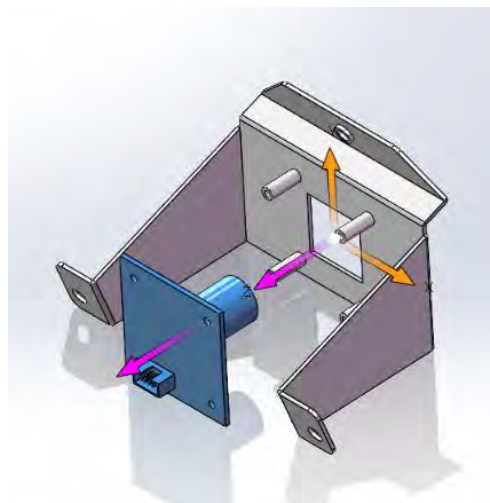

=Replacement completed=

6.2.2 Replacement of Coin Acceptor

Step 1: Open the coin door with the key.



Step 2: Open the coin acceptor limiter, take out the coin acceptor.



Step 3: Replace with new coin acceptor, repeat above steps in reverse order.
=*Replacement completed*=

6.2.3 Replacement of Air Compressor

NOTE: Please ensure the tank is discharged before removal. Please disconnect all air pipes and power cable before operation.

Step 1: Remove the air compressor door screw and open the door with the key.

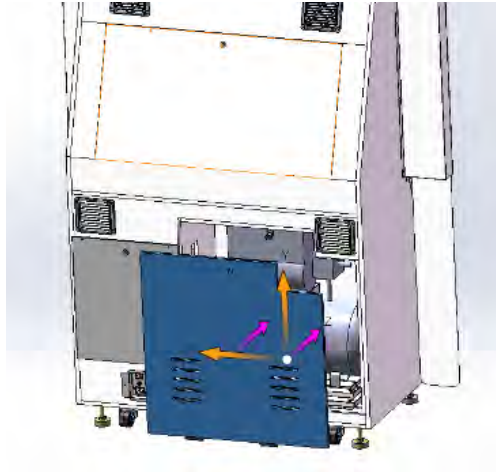

Step 2: After the air compressor has drained all the water, remove the air pipes from the air outlet and drainage outlet.

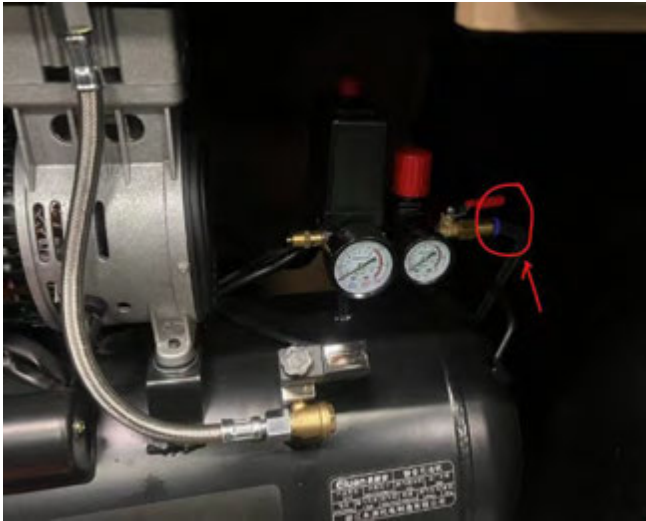

Step 3: Remove the screws from the air compressor components and carefully pull out the air compressor, then disconnect the electrical plug of the air compressor.

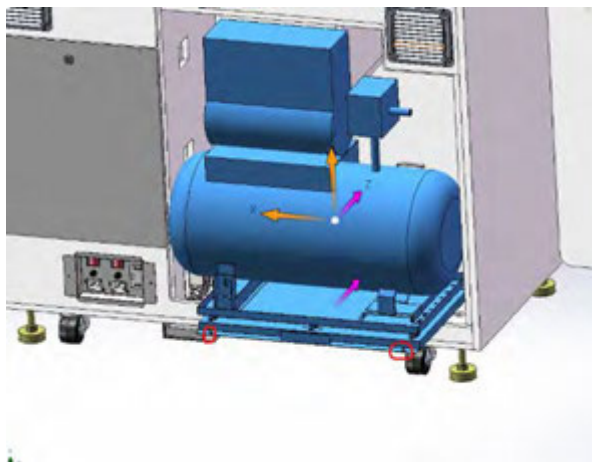

Step 4: Remove the air compressor fastening screw and pull out the air compressor.



Step 5: Replace with new air compressor, repeat the above steps in reverse order.

=Replacement completed

6.2.4 Replacement of Boost Handle

Step 1: Remove the fixed screws of the boost handle.

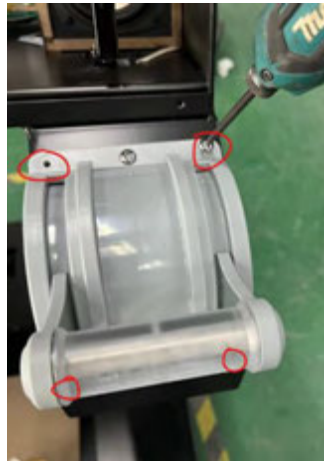

Step 2: Carefully remove and disconnect the wiring harness.



Step 3: Replace with new boost handle, repeat above steps in reverse order.

Attention: Please ensure that the marking on the potentiometer gear aligns with the markings on the side panel when the boost handle is in the initial position.



=Replacement completed=

6.2.5 Replacement of Boost Handle Switch

Step 1: Remove the boost handle (Refer to replacement of boost handle).

Step 2: Remove the switch.

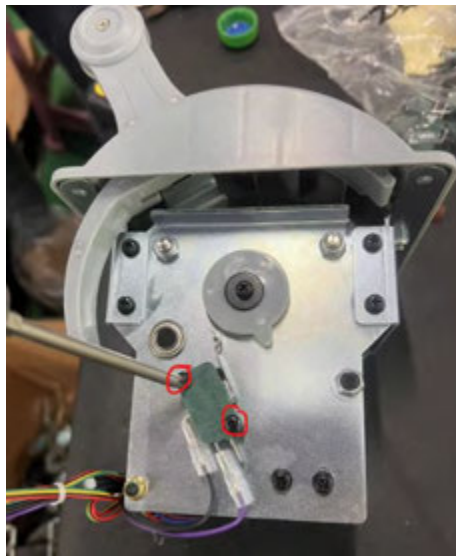

Step 3: Replace with new switch, repeat above steps in reverse order.

=Replacement completed=

6.2.6 Replacement of Boost Handle Electromagnet

Step 1: Remove the boost handle (refer to Replacement of Boost Handle).

Step 2: Remove the Electromagnet.

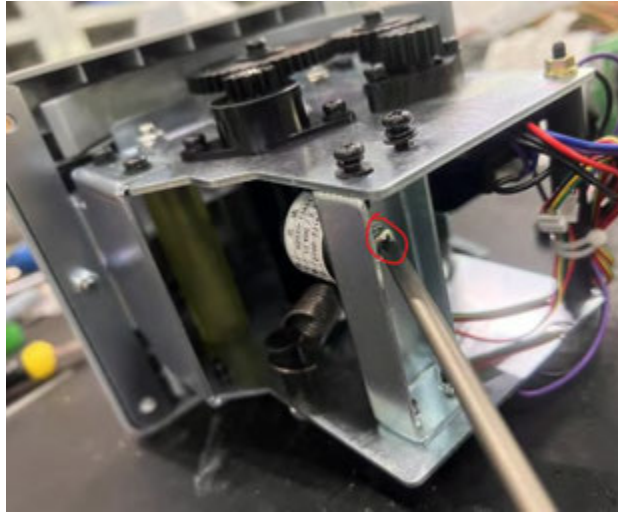

Step 3: Replace with new electromagnet, repeat above steps in reverse order.
=Replacement completed=

6.2.7 Replacement of Boost Handle Potentiometer

Step 1: Remove the boost handle (refer to Replacement of Boost Handle).

Step 2: Remove the potentiometer plate.

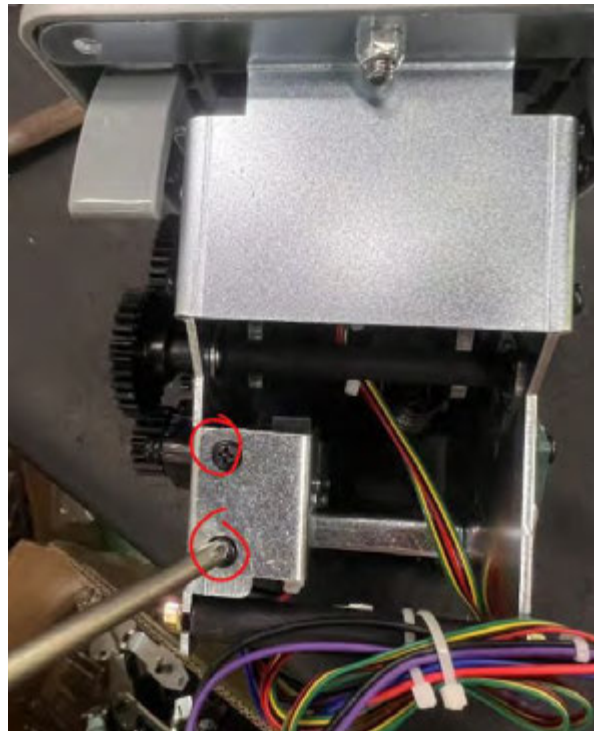

Step 3: Replace with new potentiometer, repeat above steps in reverse order.

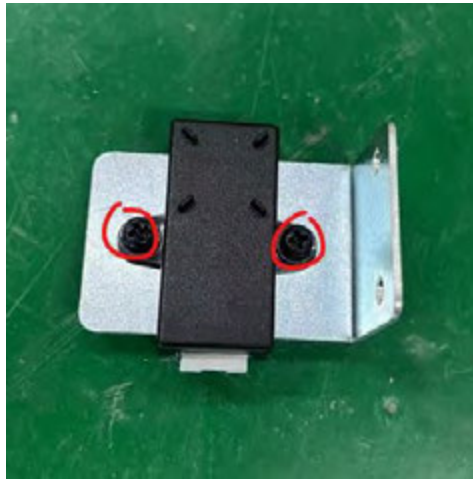

=Replacement completed=

6.3 Air Compressor Maintenance Guide

6.3.1 Pre-use Preparation

1. This product should be used in a clean, dry and well-ventilated place.
2. The supply voltage must be kept at $\pm 10\%$ of the rated voltage.
3. Open the exhaust valve and unplug the button on the air pressure switch, let the compressor idle for 10 minutes, and then use it again.



6.3.2 Operation and Adjustment

1. During normal operation, the air compressor is controlled by the air pressure switch. When the rated working pressure reaches 0.8Mpa, the air pressure switch will be automatically disconnected, and when the pressure drops to about 0.6Mpa, the switch will be activated.

The rated working pressure has been set in the factory, generally users should not adjust the setting value without authorization.

When the air compressor stops working, the compressed air in the exhaust pipe will be discharged automatically through the relief valve under the air pressure switch to prepare for another (no-load) start-up, otherwise it will cause starting difficulties or damage to the motor when it starts again.

If necessary, the working pressure can be adjusted by the adjusting screw on the air pressure switch (see Fig. 3), but only allow to be adjusted lower (i.e. $\leq 0.8\text{Mpa}$) and never adjusted higher, otherwise the safety valve will be automatically opened to exhaust, so that the air compressor cannot be used normally.

2. The output pressure of the air compressor can be adjusted by the regulator. Turn it clockwise or anti-clockwise to adjust the exhaust pressure.

When it is necessary to stop the compressor during operation, press the button on the air pressure switch.

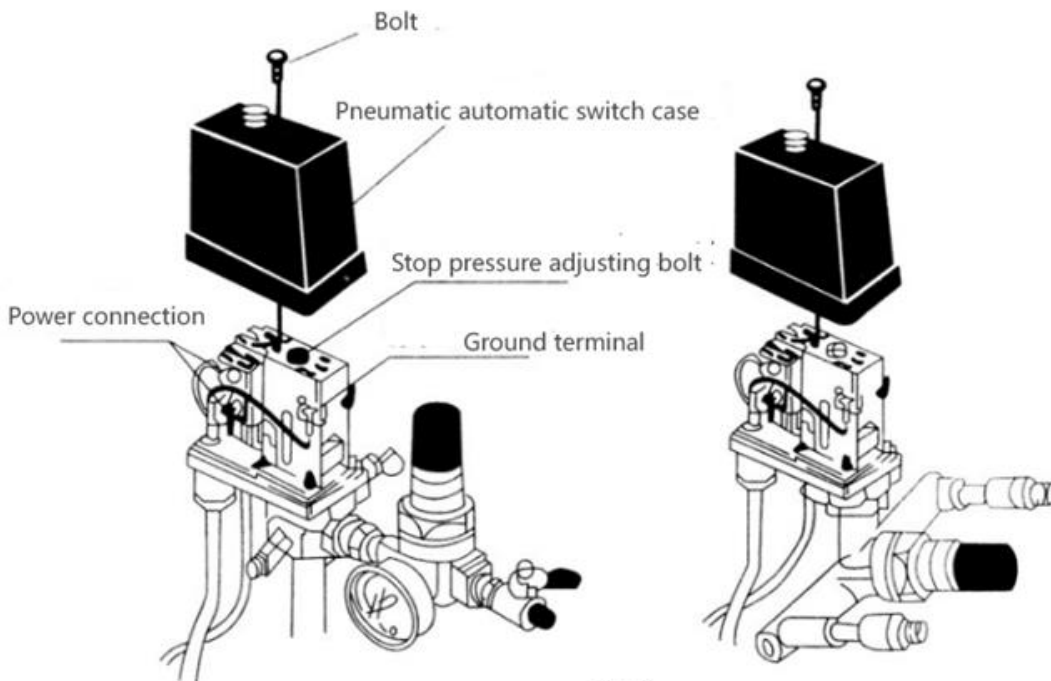

Fig. 3

6.4 Air Compressor Malfunction and Troubleshooting

6.4.1 Air Compressor Parts List

NOTE: Component parts are NOT available as purchase items. The below list is for maintenance and general information only.

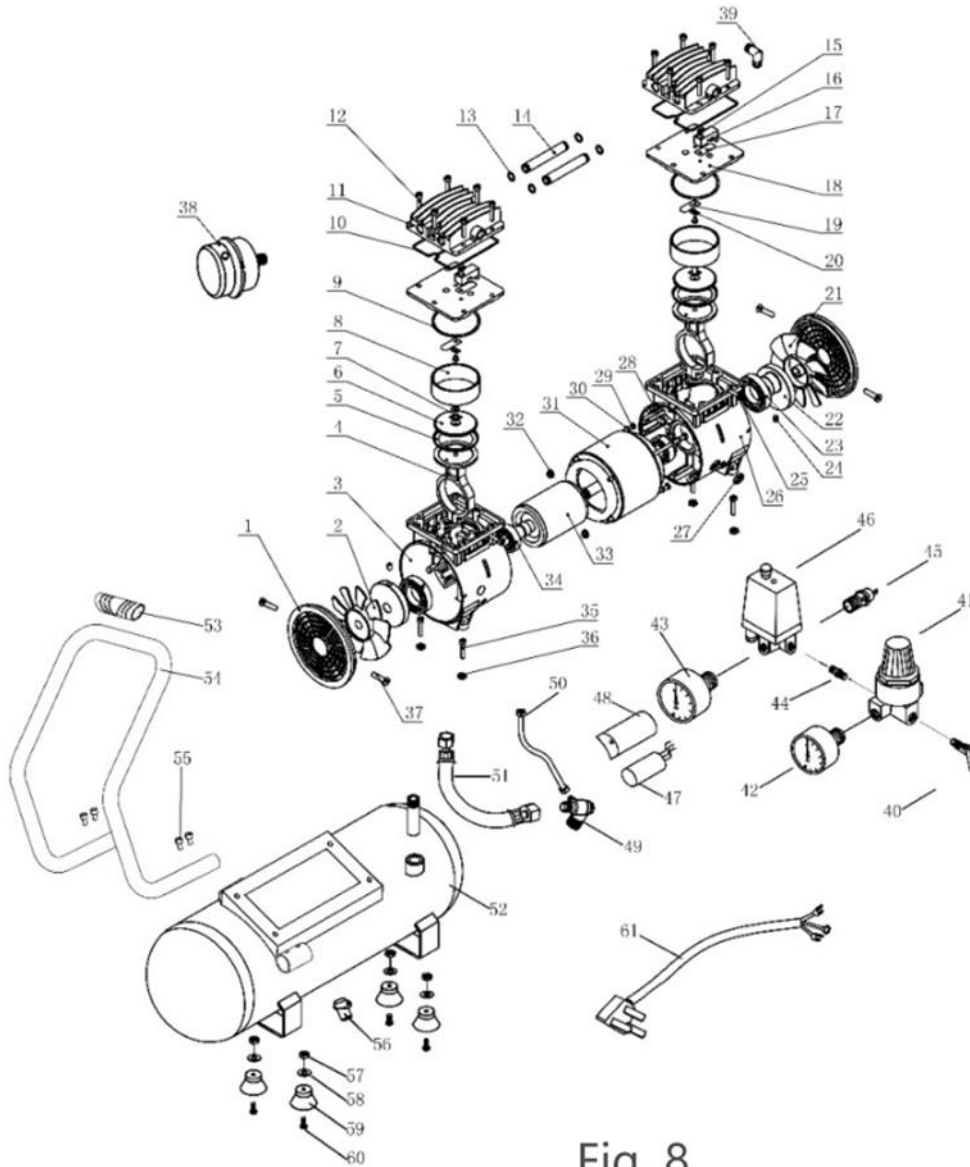

Fig. 8

S.N.	Name	QTY
1	Windshield	2
2	Left Fan	1
3	Left Chamber	1
4	Connecting Rod	2
5	Piston Bowl	2
6	Press Board	2
7	Cross Recessed Countersunk Head Screw	2

8	Cylinder	2
9	Cylinder Seal	2
10	Cylinder Head Seal	2
11	Cylinder Head Seal	2
12	Hexagon Socket Cheese Head Screws	12
13	Connection Tube Seal	4
14	Connection Tube Seal	2
15	Cross Recessed Pan-head Screws	2
16	Limit Block	2
17	Outlet Valve Blade	2
18	Valve Plate	2
19	Intake Valve Blade	2
20	Metal Gasket	2
21	Left Fan	2
22	Crank	1
23	Bearing 6006-2Z	2
24	Hexagon Socket Set Screws with Flat Point	2
25	Hexagon Socket Cheese Head Screws	2
26	Right Chamber	1
27	Lead Wire Protection Ring	1
28	Hexagon Socket Cross Head Bolts	2
29	Cross Recessed Pan-head Screws	2
30	Light Spring Washers	4
31	Stator	1
32	Hexagonal Flange Face Locknuts	4
33	Rotor	1
34	Bearing 6203-2Z	2
35	Hexagon Socket Cheese Head Screws	4
36	M6 Nut	4
37	Self-tapping Screw	4
38	Silencers	1
39	Bends	1
40	Venting Valve	1
41	Pressure-regulating Valve	1
42	40 Pressure Gauge	1
43	50 Pressure Gauge	1
44	Double-sided Joints	1
45	Safety Valves	1
46	Pressure Switch	1
47	Capacitors	1
48	Capacitor Case	1
49	One-way Valve	1
50	Unloading Tube	1
51	High Pressure Hose	1

52	Gas Canister	1
53	Knob Cover	1
54	Knob	1
55	Hexagon Socket Cheese Head Screws	4
56	Drain Valve	1
57	M6 Nut	4
58	Gasket	4
59	Boss Machine Foot Mats	4
60	Foot Screws	4
61	Power Cable	1

6.4.2 Air Compressor Troubleshooting

No.	Fault Phenomenon	Possible Cause	Methods of Troubleshooting
1	Air compressor does not work; No motor sound.	1) Socket has no power.	Power On.
		2) Overcurrent protector or pressure controller is not connected.	Check if the wiring of the overcurrent protector and the pressure controller is connected.
2	Air compressor stops when setting is not set to the maximum pressure.	1) Pressure switch setting is in low.	Adjust the Pressure switch value to the required value.
		2) Overvoltage or under voltage, overcurrent protector is out of work.	Check voltage and replace overcurrent protector.
3	Air compressor cannot normally pneumatic, motor will stop after turning; and motor sound, but the sound disappears after 10~30 seconds.	1) Voltage is too low.	Increase the voltage regulator and start the air compressor again when the voltage is back to normal.
		2) The gas in the exhaust pipe is not emptied when pneumatic; Poor plug contact or intermediate power failure occurs more often.	Pull out the plug and replace the socket to ensure good contact. Turn off the air pressure switch to remove the gas in the exhaust pipe, and then turn the switch back on (time > 5 seconds)
		3) Compressor capacitor is damaged or capacity is reduced.	Replace the capacitor.
		4) Air Compressor is totally out of work.	Contact the manufacturer.
4	The compressor runs continuously, but when the pressure does not reach the stop pressure or the exhaust ball valve is closed, the time when the stop pressure is reached increases.	1) Air leakage of air compressor and piping system.	Check for leaks at each joint (soapy water can be used).
		2) Compressor head failure is out of work.	Open the cylinder cover to check whether the valve has carbon deposit and whether the valve is warped or leather is worn. Contact the manufacturer.

5	When air compressor is off, Air pressure drops after closing the exhaust ball valve.	1) Gas cylinder leaks at each joint.	Add glue to tighten the joint.
		2) Check valve is not sealed.	Clean the valve plug, replace the check valve or the spool.
6	Air compressor does not stop when exceeding the maximum pressure value.	Air pressure switch is out of work.	Adjust or replace the pressure controller.

7. Assembly

7.1 Assembly Tree Diagram

ATC-000000 Final assembly	ATC-010000 Seat Assembly	ATC-0101000 Base Assembly
		ATC-0102000 Motion Platform assembly
		ATC-0103000 Seat assembly
		ATC-0104000 Console assembly
		ATC-0105000 Steering Assembly
		ATC-0106000 Pedal assembly
		ATC-0107000 Console assembly
		ATC-0108000 Steering w heel assembly
		ATC-0109000 Pneumatic valve assembly
		ATC-0110000 Gearshift assembly
		ATC-0111000 Gas-jet assembly
		ATC-0112000 Left speaker assembly
		ATC-0113000 Right speaker assembly
		ATC-0114000 Left Blow er Assembled
		ATC-0115000 Right Blow er Assembled
		ATC-0116000 Coin door assembly
		ATC-0117000 Cash box assembly
		ATC-0118000 Console side door assembly
		ATC-0119000 Service panel assembly
		ATC-0120000 Rear end assembly
	ATC-0200000 65" frame assembly	ATC-0201000 Wooden frame assembly
		ATC-0202000 Air compressor assembly
		ATC-0204000 Main unit assembly
		ATC-0205000 Pow er sw itch assembly
		ATC-0206000 Transformer assembly
		ATC-0207000 Air compressor door assembly
		ATC-0208000 PC door assembly
		ATC-0209000 Fan assembly
		ATC-0210000 Intake fan assembly
		ATC-0211000 LCD door assembly
		ATC-0213000 Camera Assembly
		ATC-0214000 Filter assembly
		ATC-0215000 Sink assembly
		ATC-0216000 65" LCD Assembly
	ATC-0300000 LED Panel assembly	

7.2 General Assembly Diagram

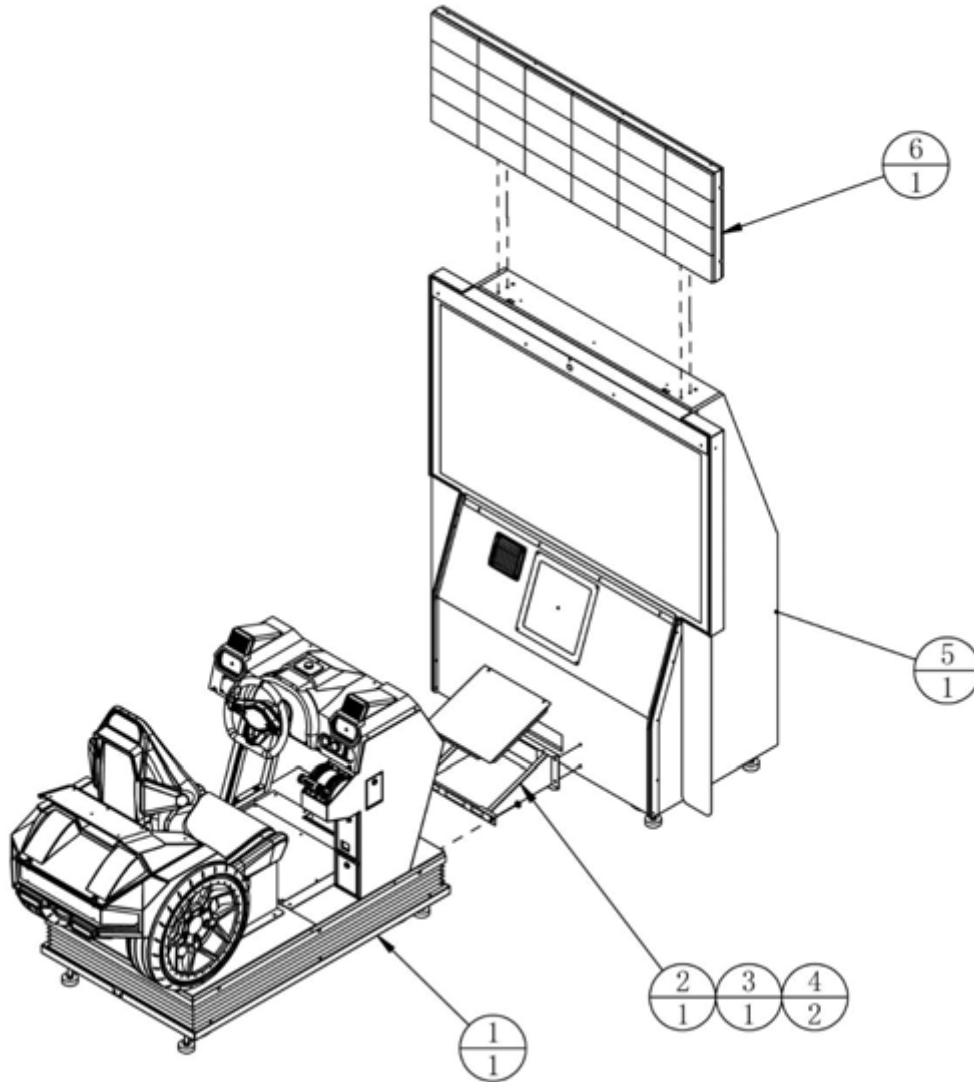

6	ATC-0300000	LED Panel assembly		1	
5	ATC-0200000	65' frame assembly		1	
4	ATC-0000A03	Spacer column	POM Black	2	
3	ATC-0000A02	Connection cover plate	SPCC-1.2T	1	
2	ATC-0000A01	Connection plate	SPCC-1.5T	1	
1	ATC-0100000	Seat Assembly		1	
No.	Drawing No.	Name	Specification	Qty	Other

7.3 Seat Assembly

Seat Assembly (1/2)

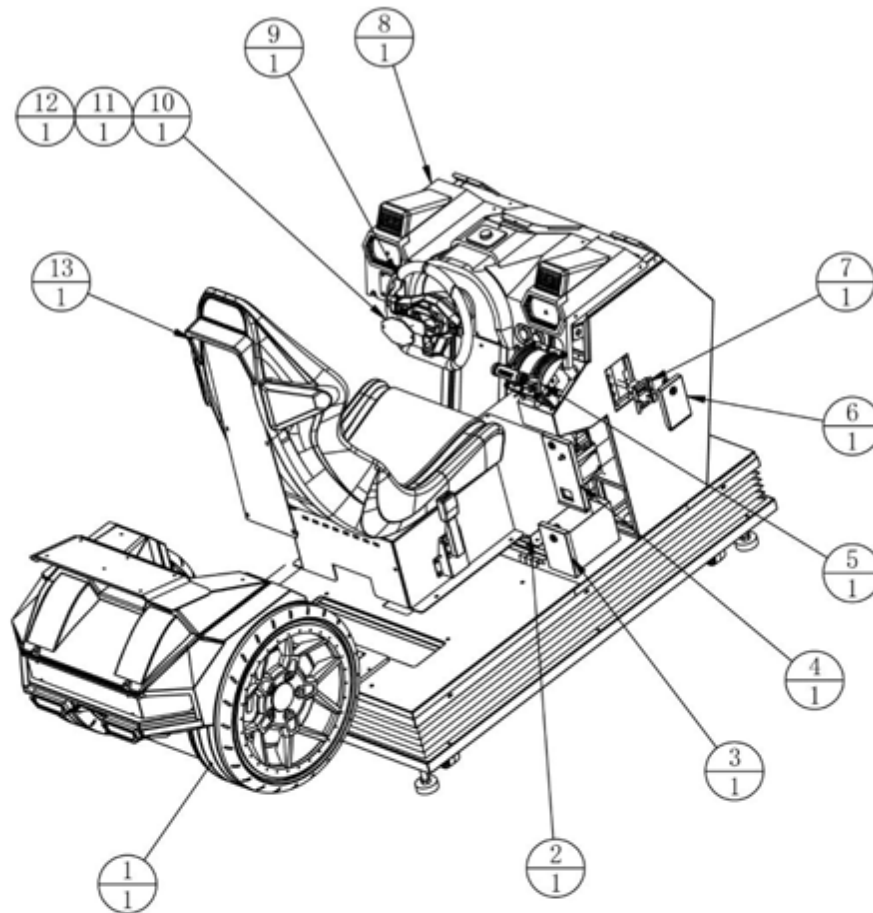

13	ATC-0103000	Seat assembly		1	
12	ATC-0100C01	Steering Wheel Covers	ABS	1	
11	ATC-0100D02	Steering Wheel Light Guide	PMMA-8.0T	1	
10	ATC-0100D01	Steering wheel trim plate	PMMA-3.0T	1	
9	ATC-0108000	Steering wheel assembly		1	
8	ATC-0107000	Console assembly		1	
7	ATC-0119000	Service panel assembly		1	
6	ATC-0118000	Console side door assembly		1	
5	ATC-0110000	Gearshift assembly		1	
4	ATC-0116000	Coin door assembly		1	
3	ATC-0117000	Cash box assembly		1	
2	ATC-0106000	Pedal assembly		1	
1	ATC-0120000	Rear end assembly		1	
No.	Drawing No.	Name	Specification	Qty	Other

Seat Assembly (2/2)

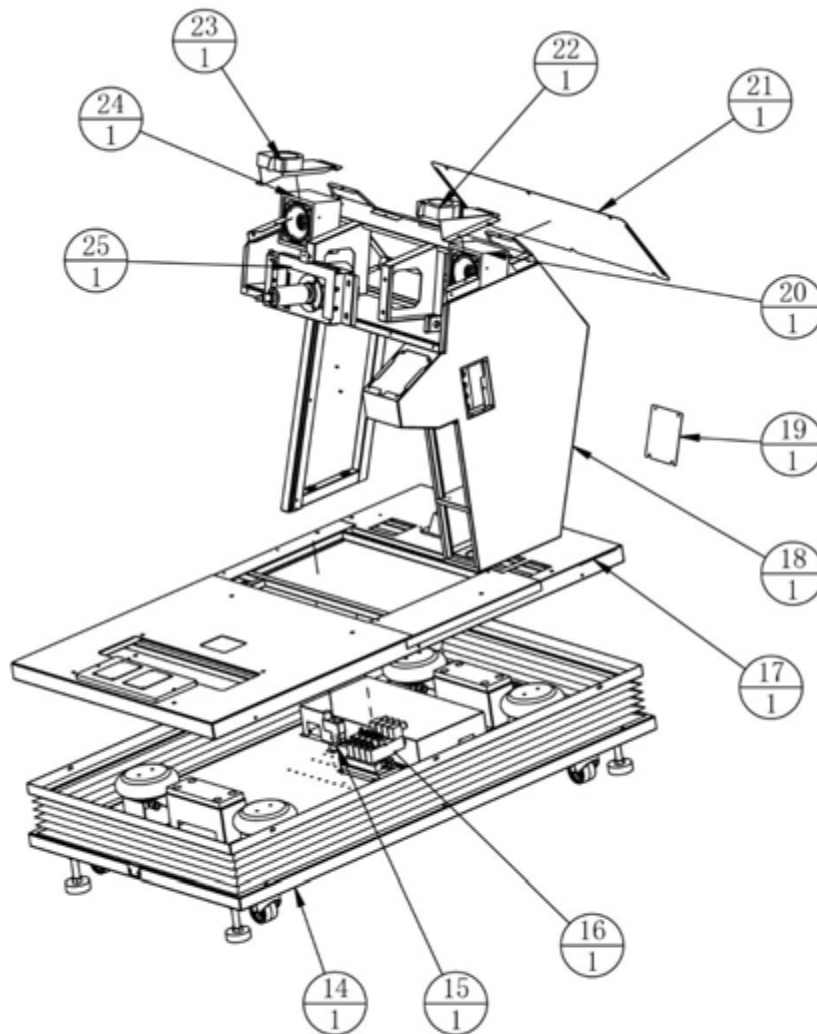

25	ATC-0105000	Steering Assembly		1	
24	ATC-0112000	Left speaker assembly		1	
23	ATC-0115000	Right Blower Assembled		1	
22	ATC-0114000	Left Blower Assembled		1	
21	ATC-0100A01	Console back cover	SPCC-1.2T	1	
20	ATC-0113000	Right speaker assembly		1	
19	ATC-0100A02	Console below cover	SPCC-1.2T	1	
18	ATC-0104000	Console assembly		1	
17	ATC-0102000	Motion Platform assembly		1	
16	ATC-0109000	Pneumatic valve assembly		1	
15	ATC-0111000	gas-jet assembly		1	
14	ATC-0101000	Base Assembly		1	
No.	Drawing No.	Name	Specification	Qty	Other

7.3.1 Base Assembly

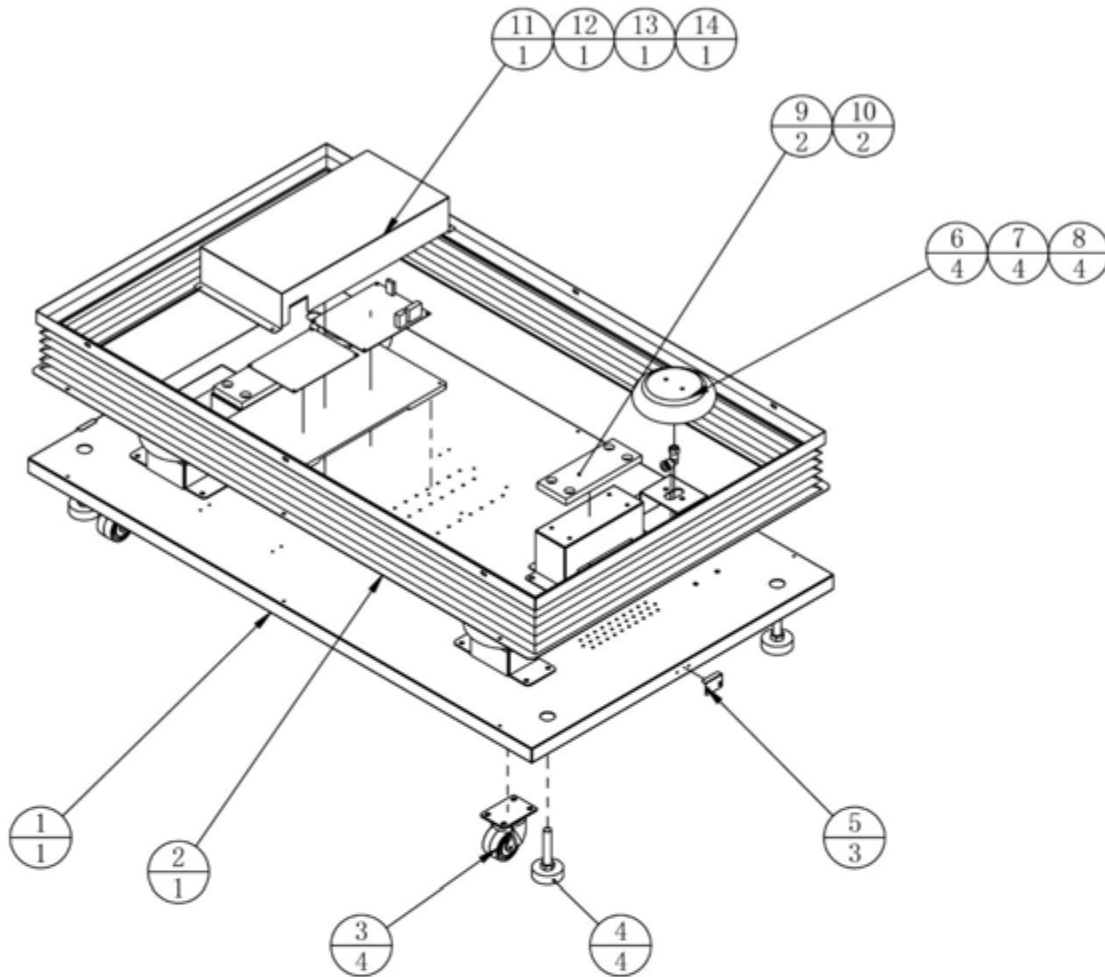

14	ATC-0101B01	PCB Plate 1	MDF-12.0T	1	
13	ATC-0101F01	RGBLEDBoard	FM-B0-03-01-01A	1	
12	ATC-0101F02	Motion board	FM-B0-02-01-02B	1	
11	ATC-0101A05	Waterproof cover	SPCC-1.0T	1	
10	ATC-0101A02	Limit base	SPCC-2.0T	2	
9	ATC-0101C01	Limit Rubber	PU	2	
8	ATC-0101A04	Airbag fixing plate	SPCC-3.0T	4	
7	TMW-0404G21	L-type threaded 2-way	APL10-02	4	
6	TMW-0403G61	Air bag	1B7070	4	
5	ATC-0101A06	Dust cover plate	SPCC-1.2T	3	
4	TMW-0102G01	Ground Screw (Rubber Bottom)	M16*100(color plated)	4	
3	TMW-0101G01	Casters		4	
2	ATC-0101A03	Dust cover		1	
1	ATC-0101A01	Base Plate		1	
No.	Drawing No.	Name	Specification	Qty	Other

7.3.2 Motion Platform Assembly

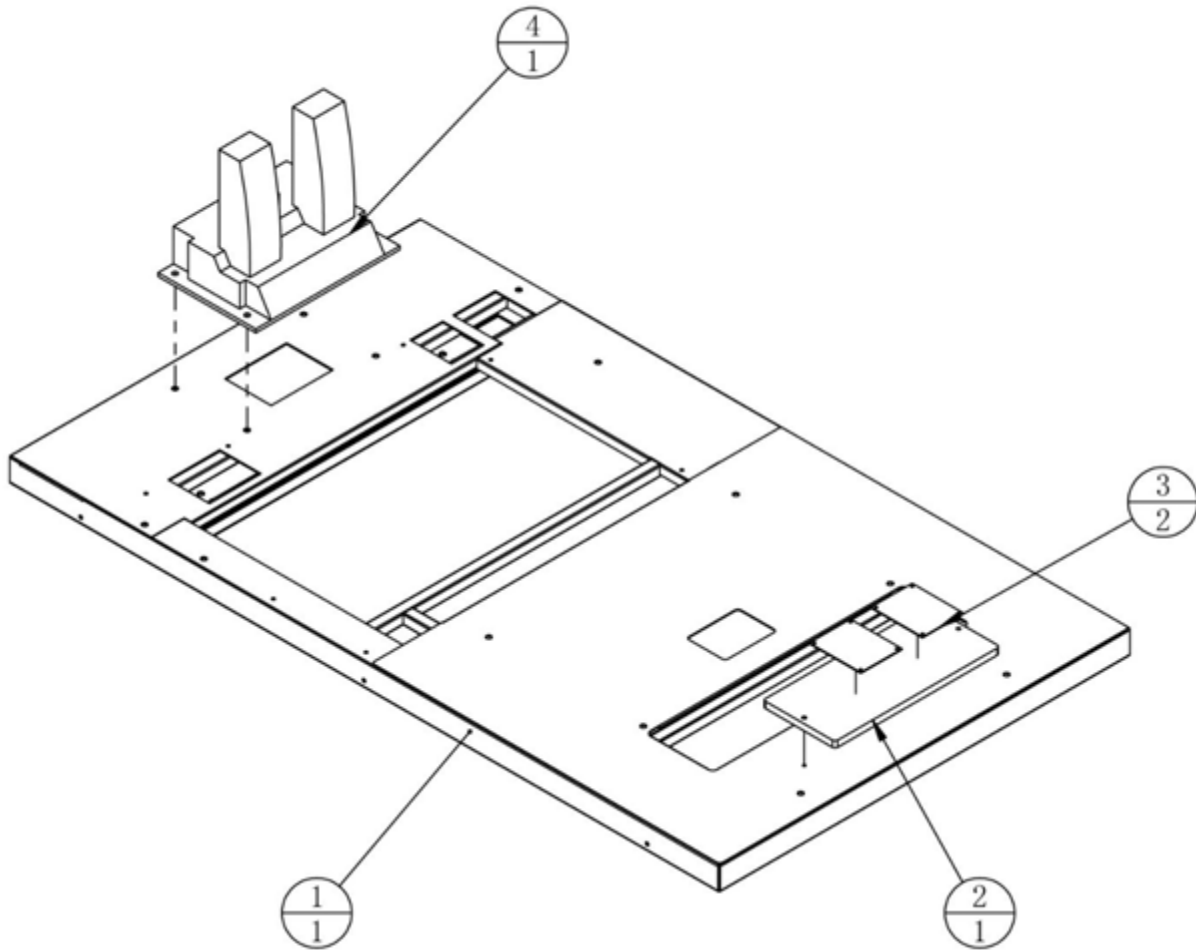

4	TMW-0403G51	Throttle Brake Components		1	
3	ATC-0102F01	SLEDBoard	FM-B0-03-02-01A	2	
2	ATC-0102B01	PCB Plate 2	MDF-12.0T	1	
1	ATC-0102A01	Motion platform		1	
No.	Drawing No.	Name	Specification	Qty	Other

7.3.3 Seat Assembly

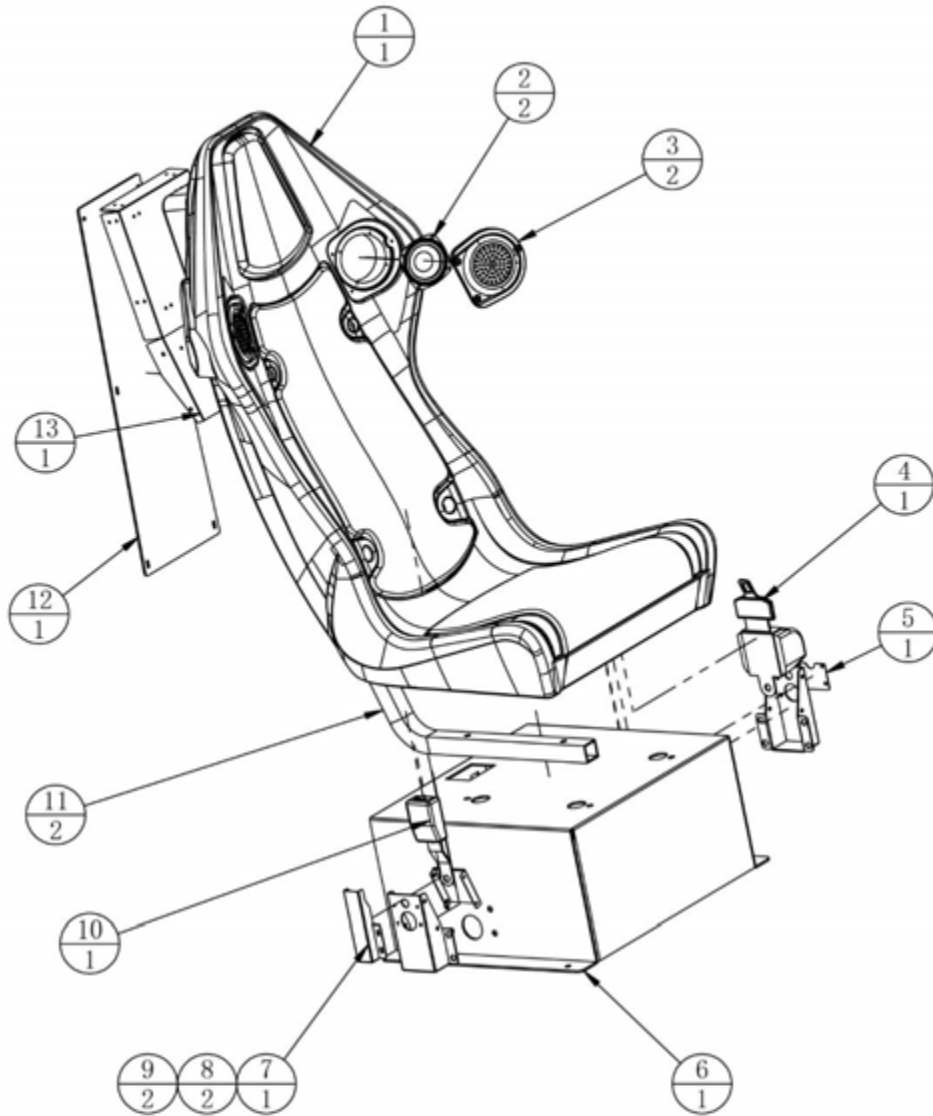

13	ATC-0103A01	Seat LED plate	SPCC-1.2T	1	
12	ATC-0103D01	Seat Decorative Panel	PMMA-3.0T	1	
11	ATC-0103A06	Seat Bend	30*30*2.5	2	
10	TMW-0601G05-01	Safety belts	Normally open	1	socket side
9	ATC-0103A03	Seat belt cover 2	SPCC-1.2T	2	
8	ATC-0103A04	Seat belt fixing iron	SPCC-2.0T	2	
7	ATC-0103A05	Seat belt cover 1	SPCC-1.5T	1	
6	ATC-0103A02	Seat Support	SPCC-3.0T	1	
5	ATC-0103A07	Wire cover	SPCC-1.2T	1	
4	TMW-0601G05-02	Safety belts	Normally open	1	rolled up end
3	ATC-0103C02	Speaker cover	ABS	2	
2	TMW-0401H07	Speaker	3' 4Ω/15W	2	
1	ATC-0103C01	Seat		1	
No.	Drawing No.	Name	Specification	Qty	Other

7.3.4 Console Assembly

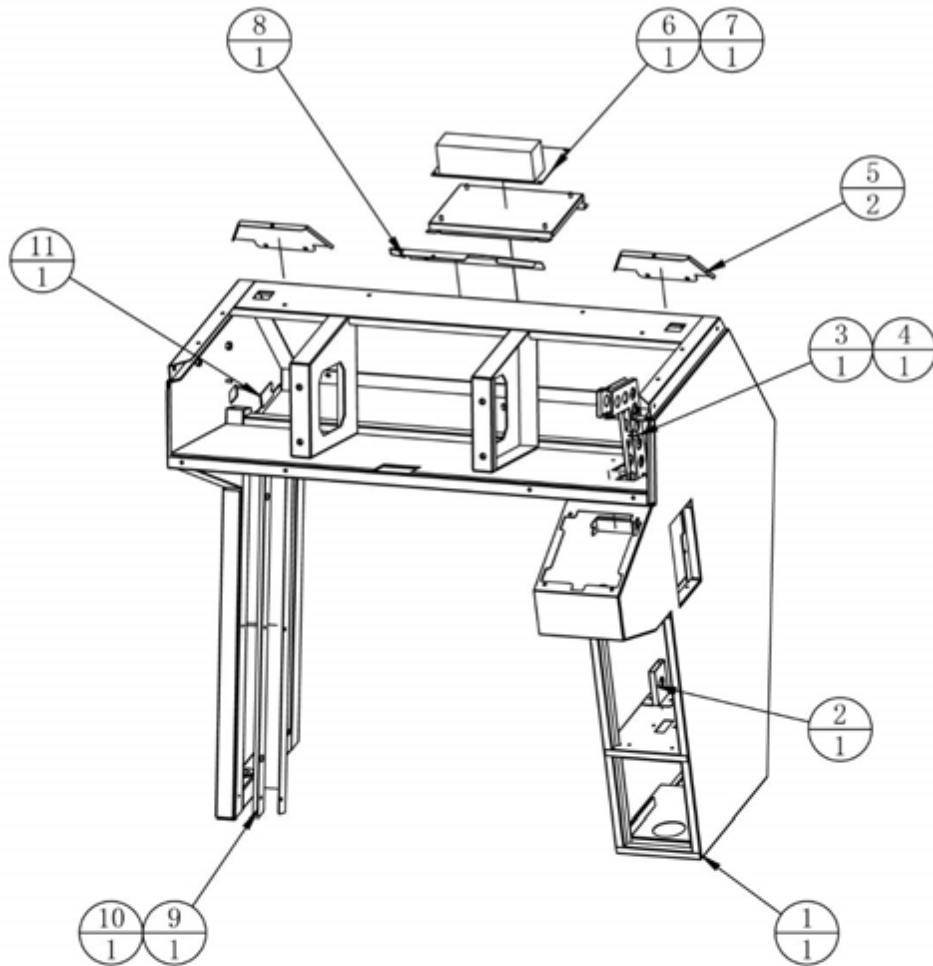

11	ATC-0104A09	DBA wire cover	SPCC-1.5T	1	
10	ATC-0104A04	Side LED cover	SPCC-1.2T	1	
9	ATC-0104D01	Side light guide plate	PMMA-8.0T	1	
8	ATC-0104A03	Back cover 2	SPCC-1.2T	1	
7	ATC-0104A08	Motor PCB plate	SPCC-1.2T	1	
6	ATC-0104F01	Motor Board	GK-PCB-2023-05-02	1	
5	ATC-0104A02	Back cover 1	SPCC-1.2T	2	
4	ATC-0104A07	Coin groove L	SECC-1.0T	1	
3	ATC-0104A06	Coin groove R	SECC-1.0T	1	
2	ATC-0104A05	Coin chute	SPCC-1.0T	1	
1	ATC-0104A01	Console assembly		1	
No.	Drawing No.	Name	Specification	Qty	Other

7.3.5 Steering Assembly

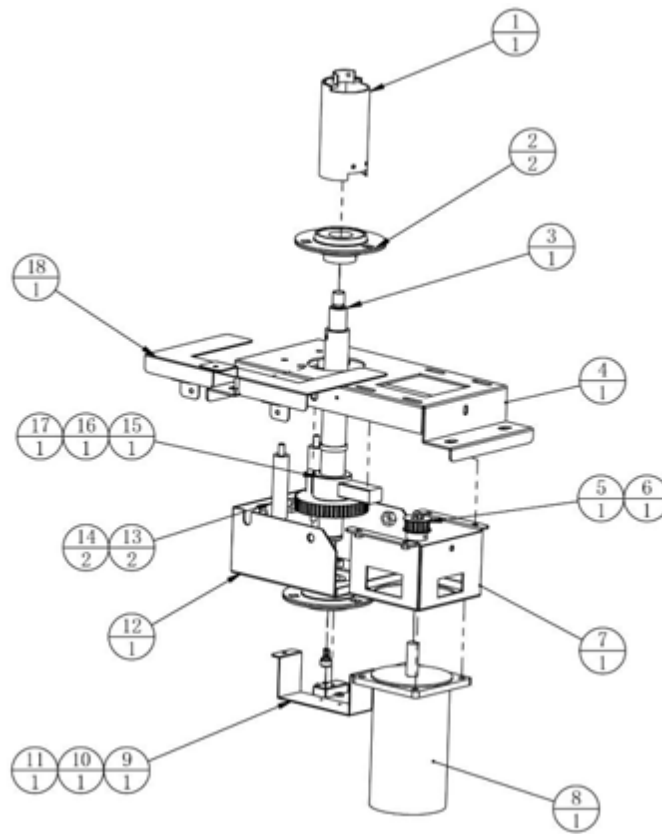

18	ATC-0105A10	LED light panel	SECC-1.2T	1	
17	ATC-0105A02	Belt pulley	AL	1	
16	TMW-0801G12	KEY	8*35 GBT1096-2003	1	
15	ATC-0105A06	Limit block		1	
14	ATC-0105A04	Limit pole	Q235	2	
13	ATC-0105C01	Directional Limit Block	PU	2	
12	ATC-0105A07	Steering Lower Cover	SECC-2.0T	1	
11	TMW-0209H01-01	Potentiometer Magnet		1	
10	TMW-0209H01-02	Potentiometer	SI9945BDY-T1-GE3	1	
9	ATC-0105A11	Potentiometer plate	SECC-1.2T	1	
8	TMW-0203H02	motor	Z5D90-90A1	1	
7	ATC-0105A08	Motor fixing support	SECC-2.0T	1	
6	TMW-0801G13	KEY	4*12 GBT1096-2003	1	
5	ATC-0105A09	Belt pulley	45	1	
4	ATC-0105A05	Steering top cover	SECC-2.0T	1	
3	ATC-0105A01	Direction Axis	45	1	
2	TMW-0501G41	Ball Bearings	UBPF205	2	
1	ATC-0105A03	Junction box		1	
No.	Drawing No.	Name	Specification	Qty	Other

7.3.6 Pedal Assembly

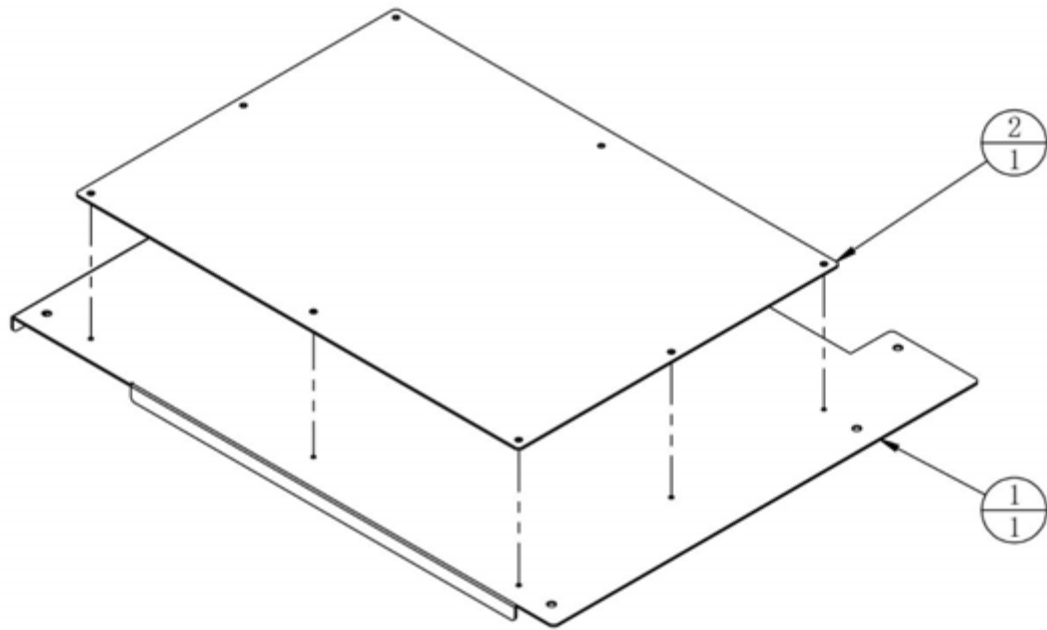

2	ATC-0106A02	Foot Pattern Plate	AL	1	
1	ATC-0106A01	Foot pedal base plate	SPCC-2.0T	1	
No.	Drawing No.	Name	Specification	Qty	Other

7.3.7 Console Panel Assembly

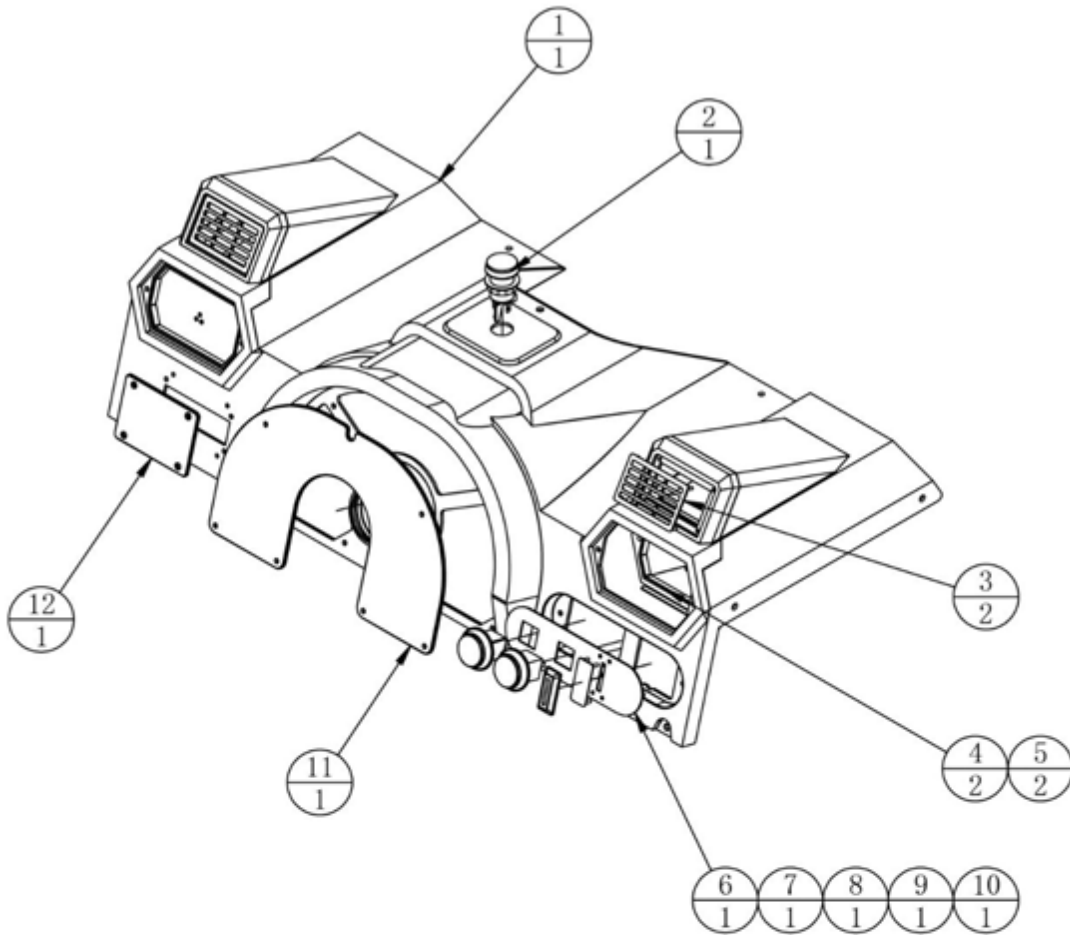

12	ATC-0107D03	Card reader board	PMMA-3.0T	1	
11	ATC-0107D01	Dashboard	PMMA-5.0T	1	
10	TMW-0301H08	VIEW BUTTON	Euro Two-Tone 42# Button-Blu	1	
9	TMW-0301H09	START BUTTON	Euro Two-Tone 42# Button - Re	1	
8	TMW-0204G11	coin slot		1	
7	ATC-0107A03	Coin cover	SPCC-1.0T	1	
6	ATC-0107A04	Button plate	SPCC-1.5T	1	
5	ATC-0107A01	Speaker net		2	
4	ATC-0107D02	Speaker light guide plate	PMMA-8.0T	2	
3	ATC-0107A02	Air outlet	SPCC-1.0T	2	
2	TMW-0301H07	Stop button	LA38-11M	1	
1	ATC-0107C01	Control panel cover	ABS	1	
No.	Drawing No.	Name	Specification	Qty	Other

7.3.8 Steering Wheel Assembly

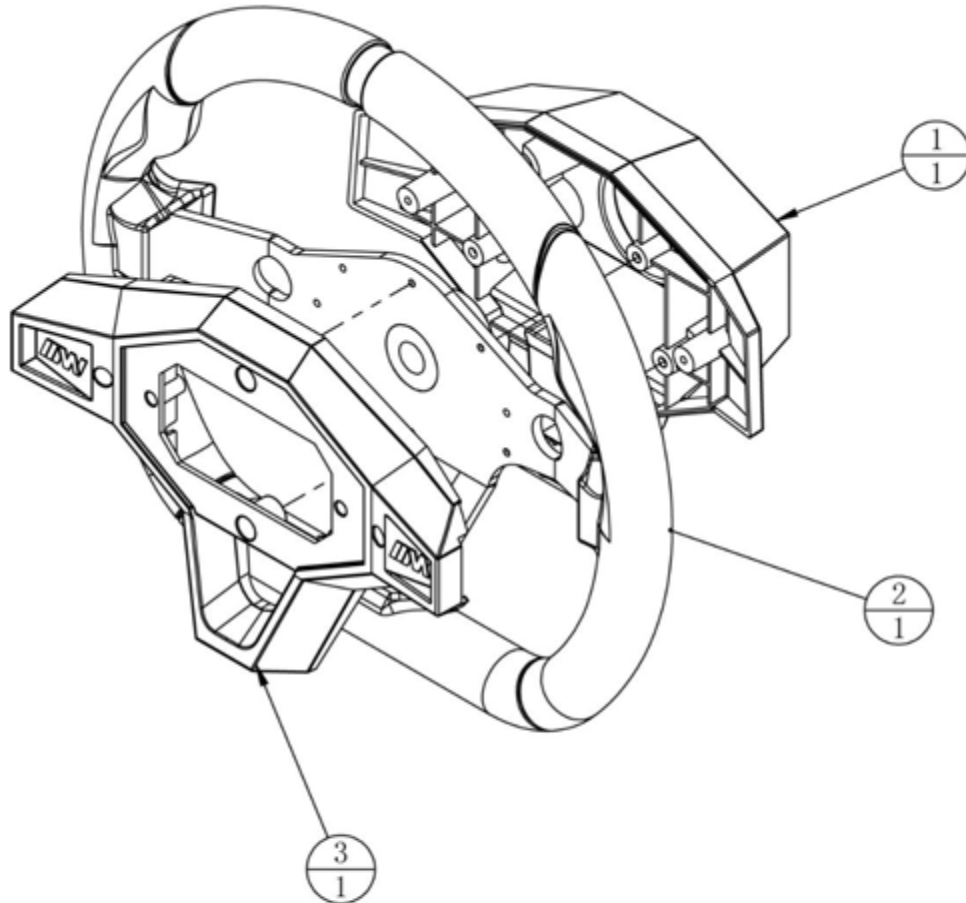

3	ATC-0108C01	Steering wheel top cover	ABS	1	
2	ATC-0108A01	Steering wheel		1	
1	ATC-0108C02	Steering Wheel Lower Cover	ABS	1	
No.	Drawing No.	Name	Specification	Qty	Other

7.3.9 Pneumatic Valve Assembly

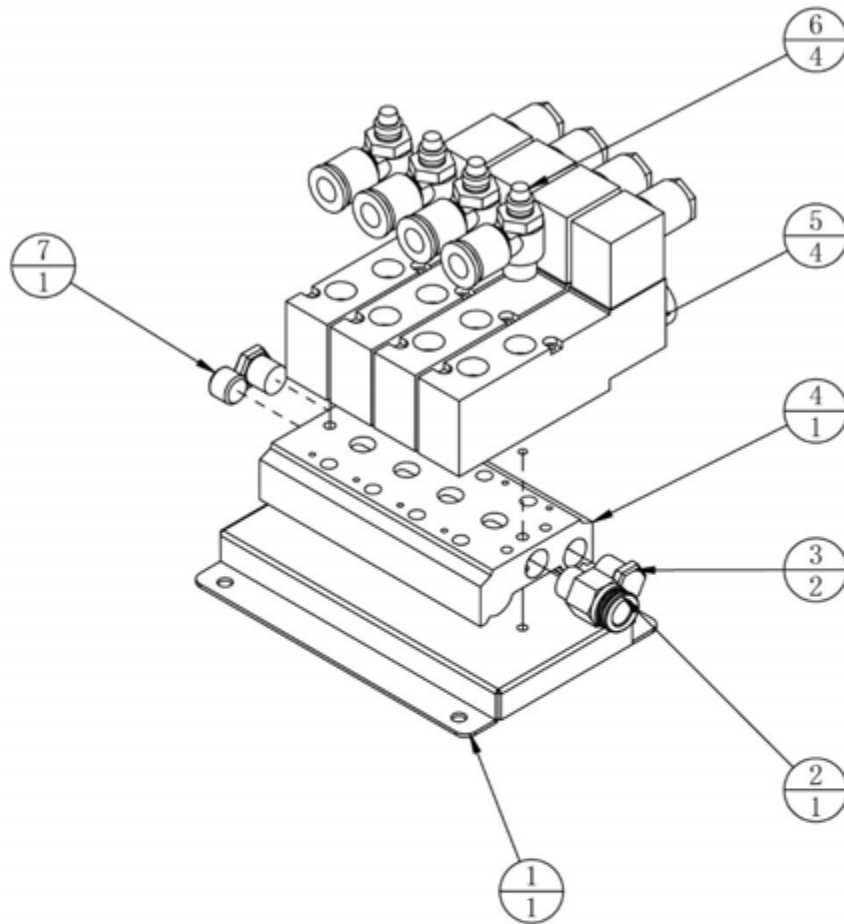

7	TMW-0404G72	Hexagonal Plug	ABP-02	1	
6	TMW-0701H03	Pipe-connected check valve	ASL10-02B	4	
5	TMW-0701H04	Fluid Control Valve	3V210-08-NC-F	4	
4	TMW-0401G03	Pneumatic Control Valve Base	3V200M-4F	1	
3	TMW-0901G12	Copper Silencer	BSLM02	2	
2	TMW-0404G01	Straight threaded Joint	APC10-02	1	
1	ATC-0109A01	Solenoid valve seat	SECC-1.5T	1	
No.	Drawing No.	Name	Specification	Qty	Other

7.3.10 Gearshift Assembly 1/2

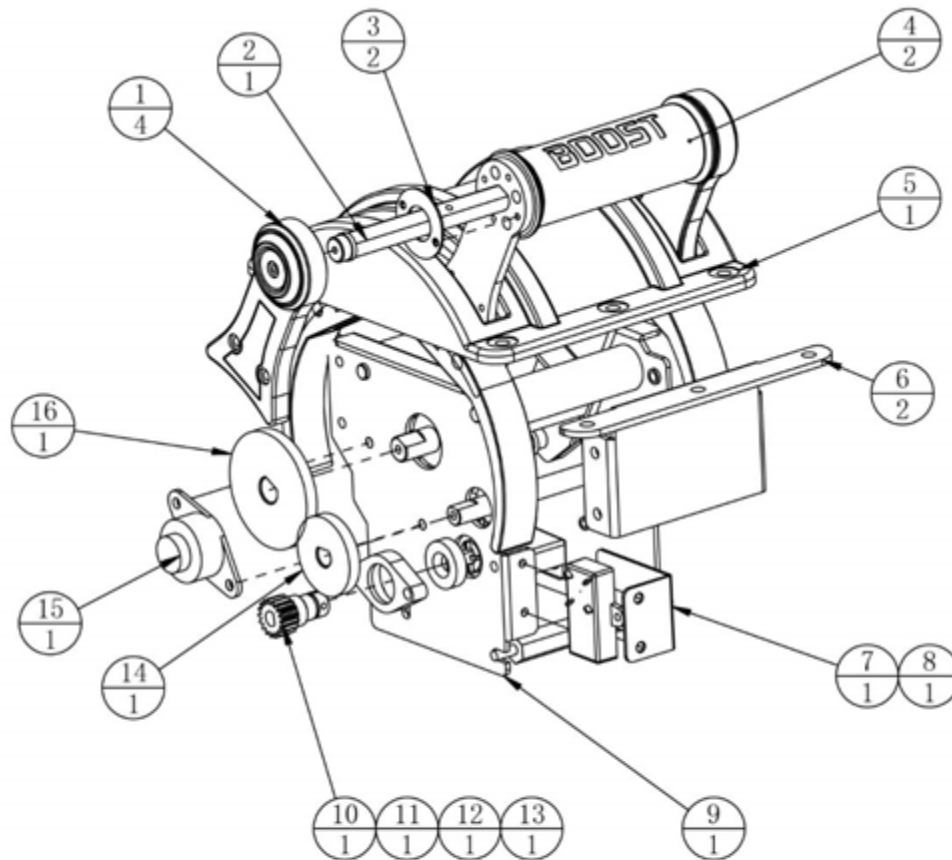

16	ATC-0110A09	Shift gears 1	AL	1	
15	TMW-0601G07	Metal one-way damper gear	LF-38A	1	
14	ATC-0110A11	Shift gears 2	AL	1	
13	TMW-0209H01-02	Potentiometer Magnet		1	
12	TMW-0501G03	Bearing	6800	1	
11	ATC-0110A19	Bearing seat	Q235	1	
10	ATC-0110A08	Potentiometer Gear	Q235	1	
9	ATC-0110A07	Gear right side panel	SPCC-2.0T	1	
8	TMW-0209H01-01	Potentiometer sensor	SI9945BDY-T1-GE3	1	
7	ATC-0110A20	Gear potentiometer plate	SPCC-1.2T	1	
6	ATC-0110A21	Gear fixing plate	SPCC-2.0T	2	
5	ATC-0110C04	Gear base cover	ABS	1	
4	ATC-0110D01	Gearshift guide light bar	PC	1	
3	ATC-0110H01	Circular light panel	RGB-12V-4	2	
2	ATC-0110A03	Gearshift upper pole	Q235	1	
1	ATC-0110C05	Gearshift side cover	ABS	2	
No.	Drawing No.	Name	Specification	Qty	Other

7.3.10 Gearshift Assembly 2/2

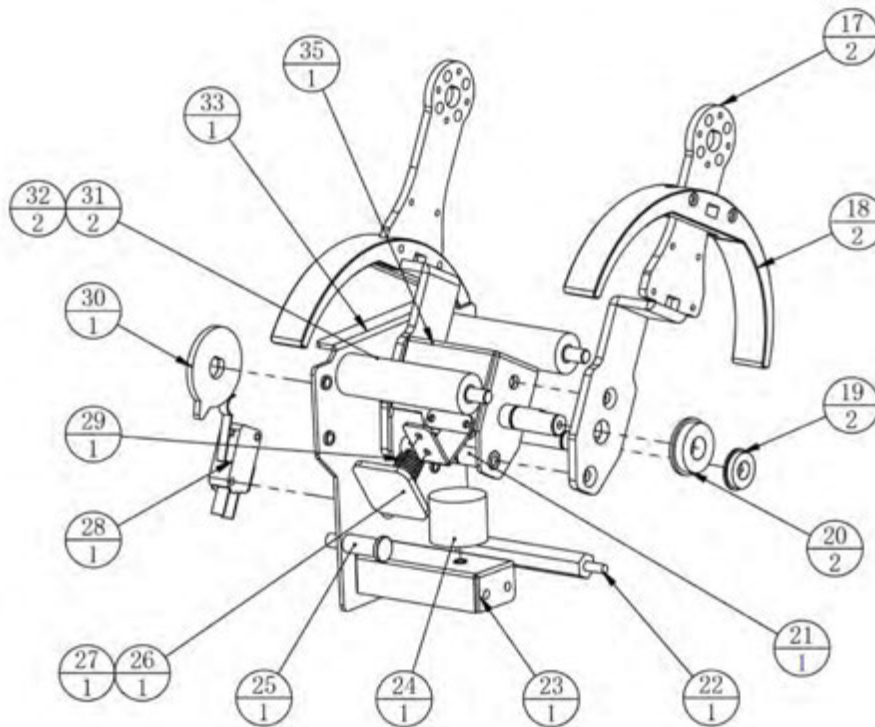

35	ATC-0110A01	Gearshift spindle		1	
34	ATC-0110A10	Gear Transmission rod	Q235	1	
33	ATC-0110A06	Gear left side panel	SPCC-2.0T	1	
32	ATC-0110A12	Spacing Pole	Q235	2	
31	ATC-0110C03	Gear buffer rod	PU	2	
30	ATC-0110C02	Switching chip	POM	1	
29	ATC-0110A16	Tension spring	65Mn	1	
28	TMW-0103H05	microswitch	3P KW3A	1	
27	ATC-0110A13	Magnetic pads	SUS430-1.2T	1	
26	ATC-0110A18	Magnetic board	SECC-3.0T	1	
25	ATC-0110A15	Tension spring retaining rod	Q235	1	
24	TMW-0208H01	Electromagnet	H2520-12V	1	
23	ATC-0110A14	Magnet fixing plate	SPCC-1.5T	1	
22	ATC-0110A17	Magnetic suction plate	45	1	
21	ATC-0110A05	Gear lower pole	Q235	1	
20	TMW-0501G22	Retaining edge bearing	F61900	2	
19	TMW-0501G21	Retaining edge bearing	F618-8	2	
18	ATC-0110C01	Guidance Blocks	POM	2	
17	ATC-0110A02	Gear lever	SPCC-4.0T	2	
No.	Drawing No.	Name	Specification	Qty	Other

7.3.11 Gas-Jet Assembly

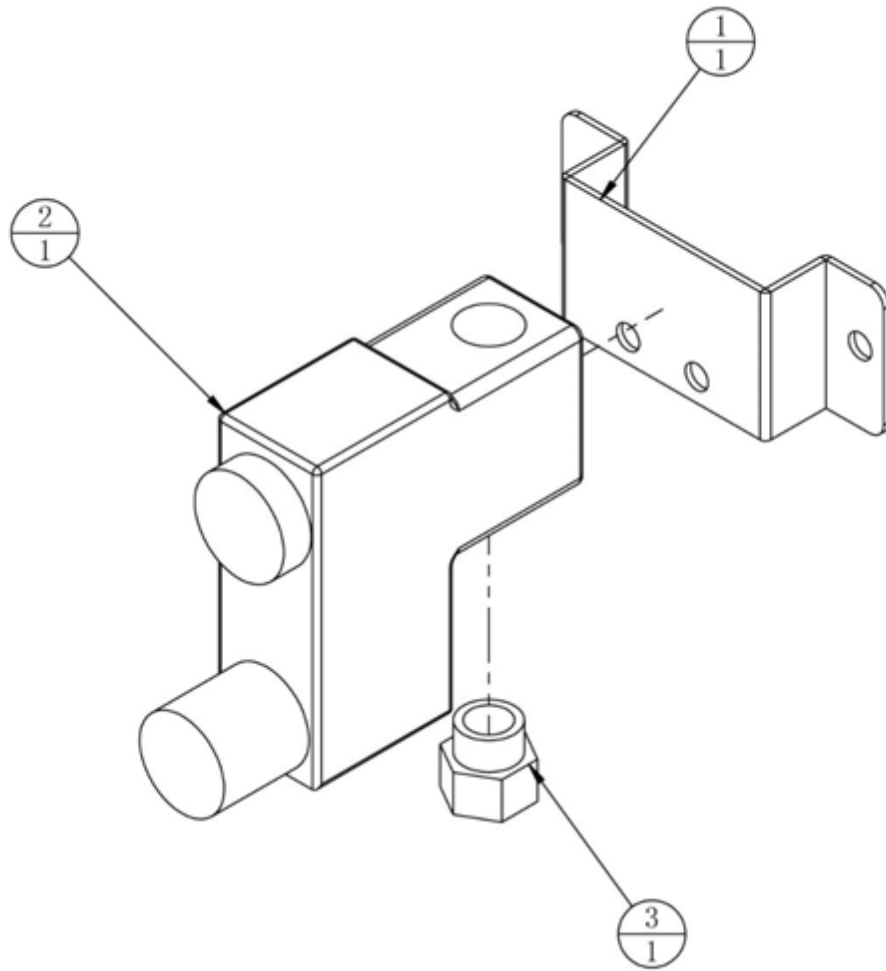

3	TMW-0404G01	Straight threaded Joint	APC10-02	1	
2	TMW-0701H02	Fulid Control Valve	2V025-08	1	
1	ATC-0111A01	Air valve fixing plate	SPCC-1.2T	1	
No.	Drawing No.	Name	Specification	Qty	Other

7.3.12 Left Speaker Assembly

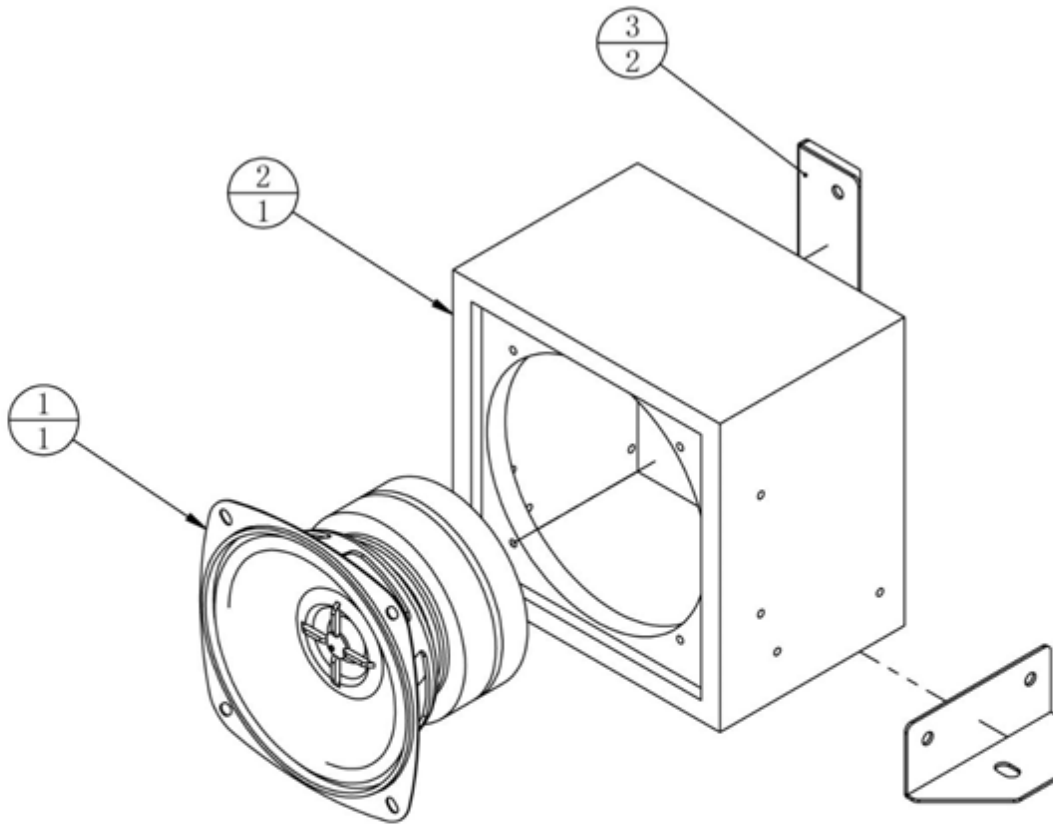

3	ATC-0112A01	Speaker fixing support	SPCC-1.2T	2	
2	ATC-0112B01	Speaker Box	MDF-9.0T	1	
1	TMW-0401H09	Speaker	4" 8Ω 60W	1	
No.	Drawing No.	Name	Specification	Qty	Other

7.3.13 Right Speaker Assembly

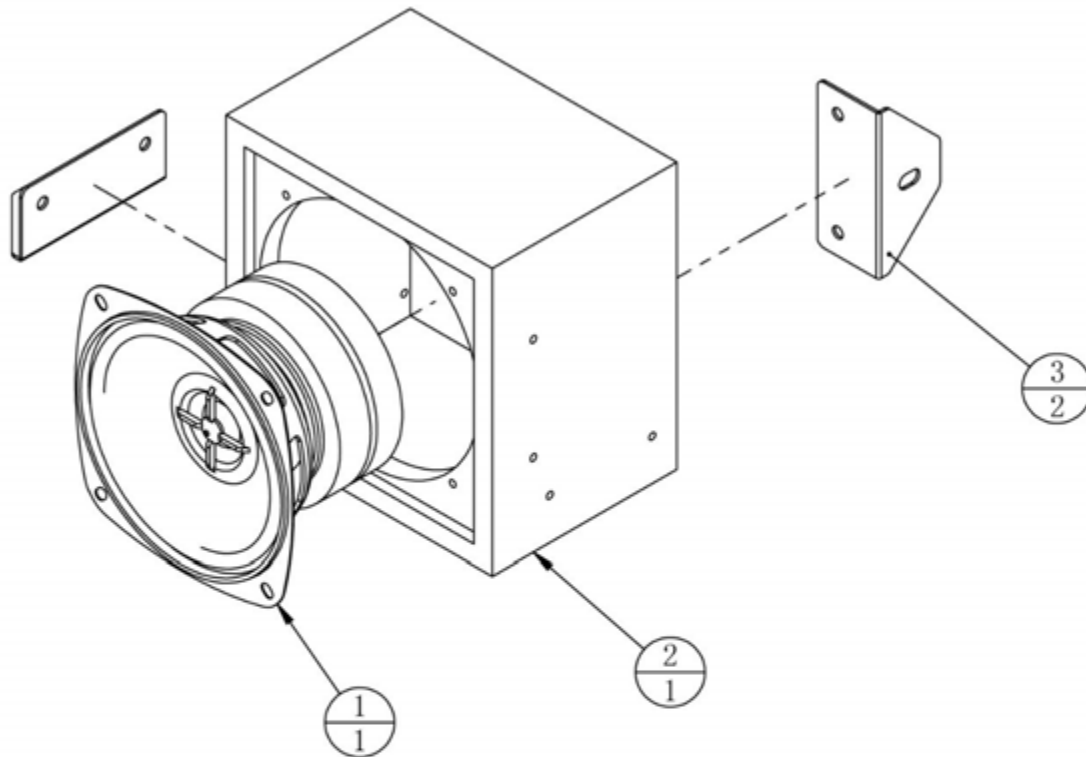

3	ATC-0112A01	Speaker fixing support	SPCC-1.2T	2	
2	ATC-0112B01	Speaker Box	MDF-9.0T	1	
1	TMW-0401H09	Speaker	4'8Ω 60W	1	
No.	Drawing No.	Name	Specification	Qty	Other

7.3.14 Left Blower Assembly

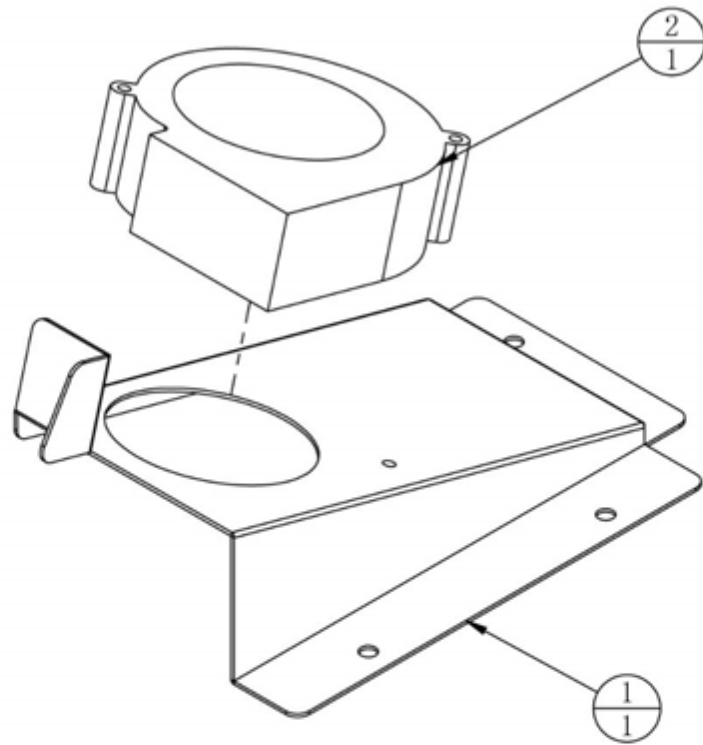

2	TMW-0202H02	Turbofan	BA10033B12GP016	1	
1	ATC-0114A01	Right blower plate	SPCC-1.5T	1	
No.	Drawing No.	Name	Specification	Qty	Other

7.3.15 Right Blower Assembly

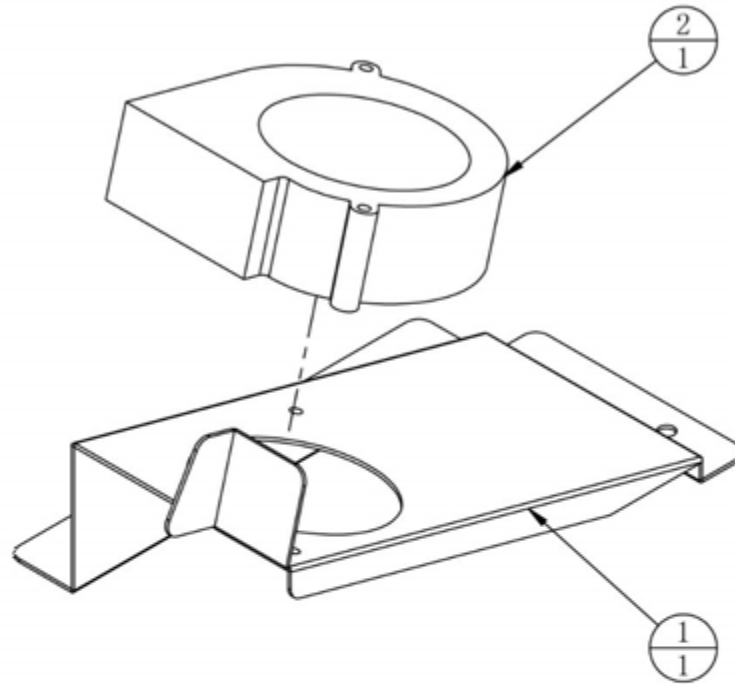

2	TMW-0202H02	Turbofan	BA10033B12GP016	1	
1	ATC-0115A01	Left blower plate	SPCC-1.2T	1	
No.	Drawing No.	Name	Specification	Qty	Other

7.3.16 Coin Door Assembly

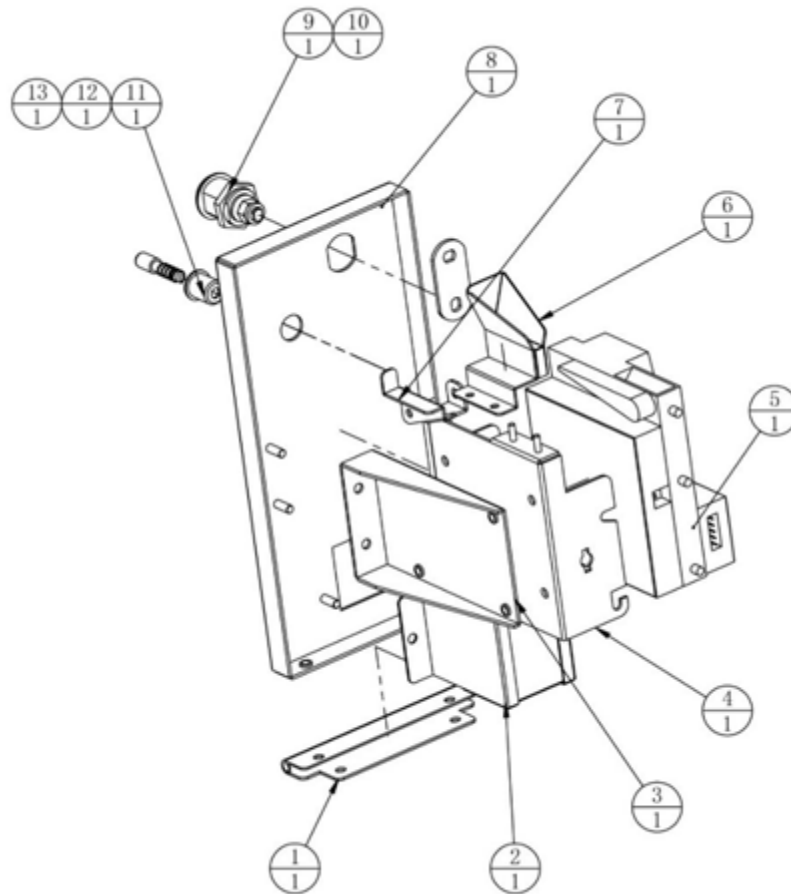

13	ATV-0216A09	Coin refund Lever	Q235	1	
12	ATV-0216A10	Coin refund Lever Spring	60Mn	1	
11	ATV-0216A08	Coin refund Lever cover	Q235	1	
10	TMW-0203G04	Lock tab	4cm(003)	1	
9	TMW-0201G06	Lock	5555-S	1	
8	ATC-0116A01	Coin door	SPCC-1.5T	1	
7	ATV-0216A06	Coin refund Platen	SPCC-1.2T	1	
6	ATC-0116A03	Coin rim	SECC	1	
5	TMW-0204H01	Coin Acceptor	LK825	1	
4	ATV-0216A01	Coin refund racks	SECC-1.5T	1	
3	ATV-0216A02	Coin refund Fixing Plate	SECC-1.5T	1	
2	ATV-0216A05	Coin refundhopper		1	
1	ATC-0116A02	Coin door Hinge	SPCC-1.2T	1	
No.	Drawing No.	Name	Specification	Qty	Other

7.3.17 Cash Box Assembly

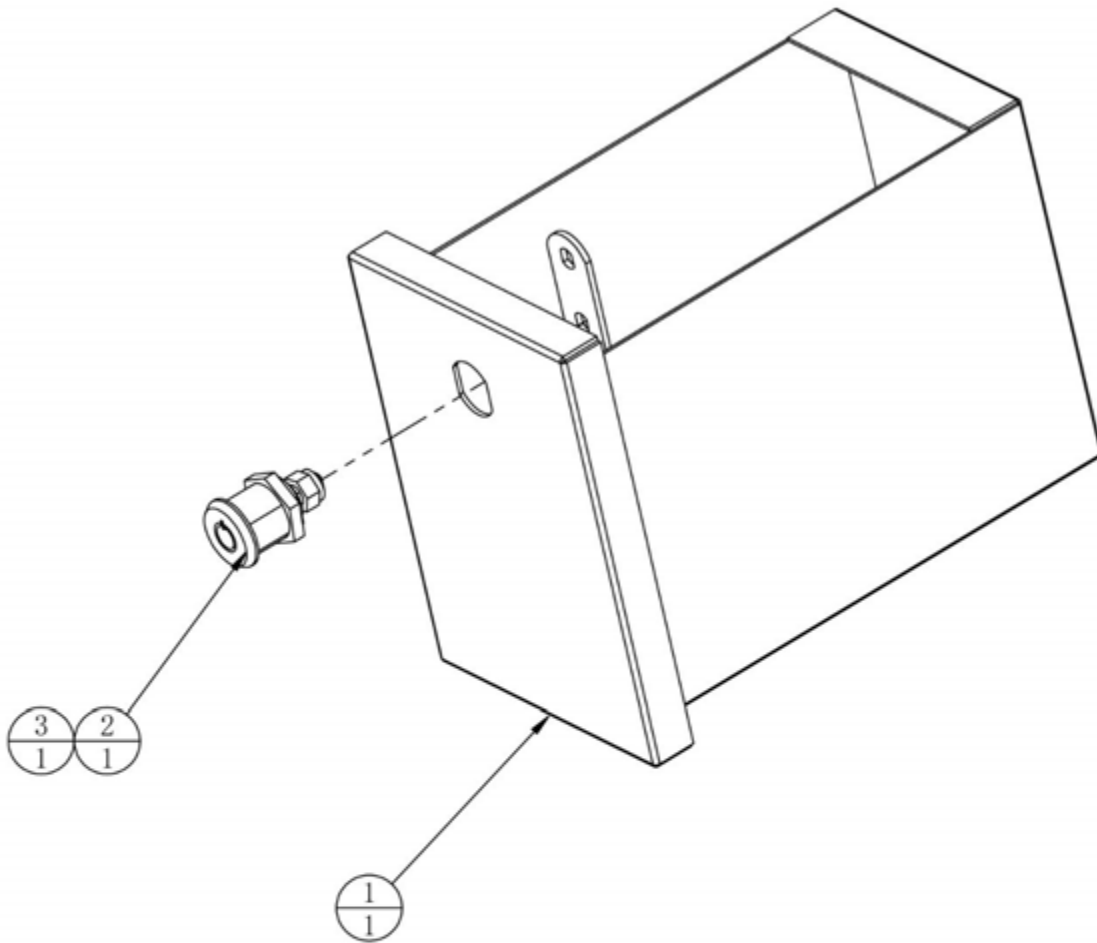

3	TMW-0203G03	Lock tab	5cm(004)	1	
2	TMW-0202G01	Lock	M7-S	1	
1	ATC-0117A01	Cash Door		1	
No.	Drawing No.	Name	Specification	Qty	Other

7.3.18 Console Side Door Assembly

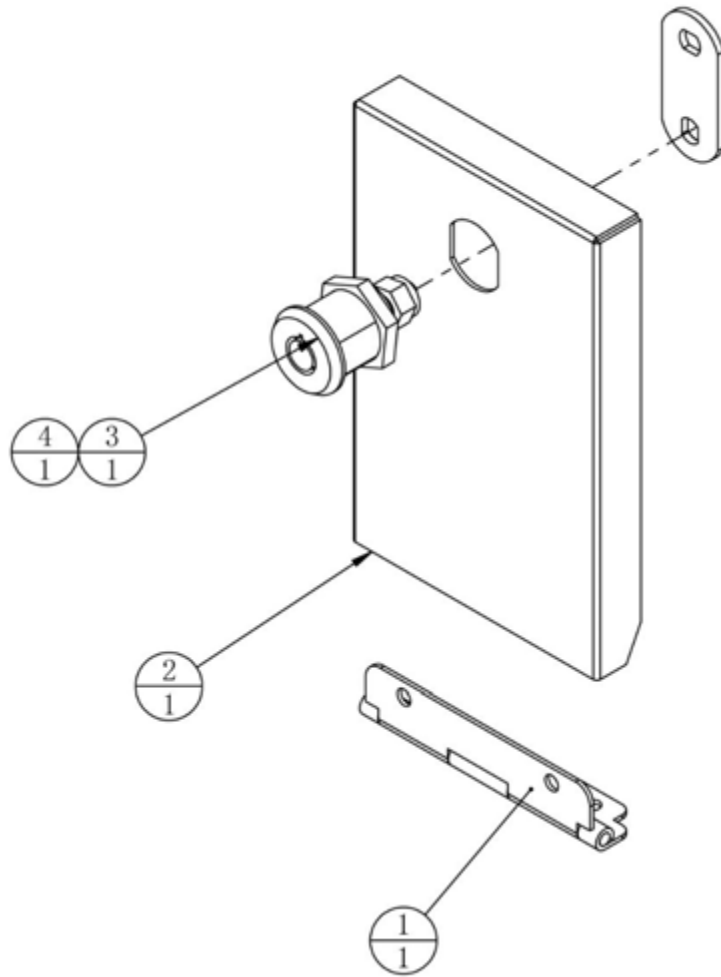

4	TMW-0203G04	Lock tab	4cm(003)	1	
3	TMW-0201G07	Lock	5555-S	1	
2	ATC-0118A02	Service door	SPCC-1.2T	1	
1	ATC-0118A01	Service door hinges	SPCC-1.2T	1	
No.	Drawing No.	Name	Specification	Qty	Other

7.3.19 Service Panel Assembly

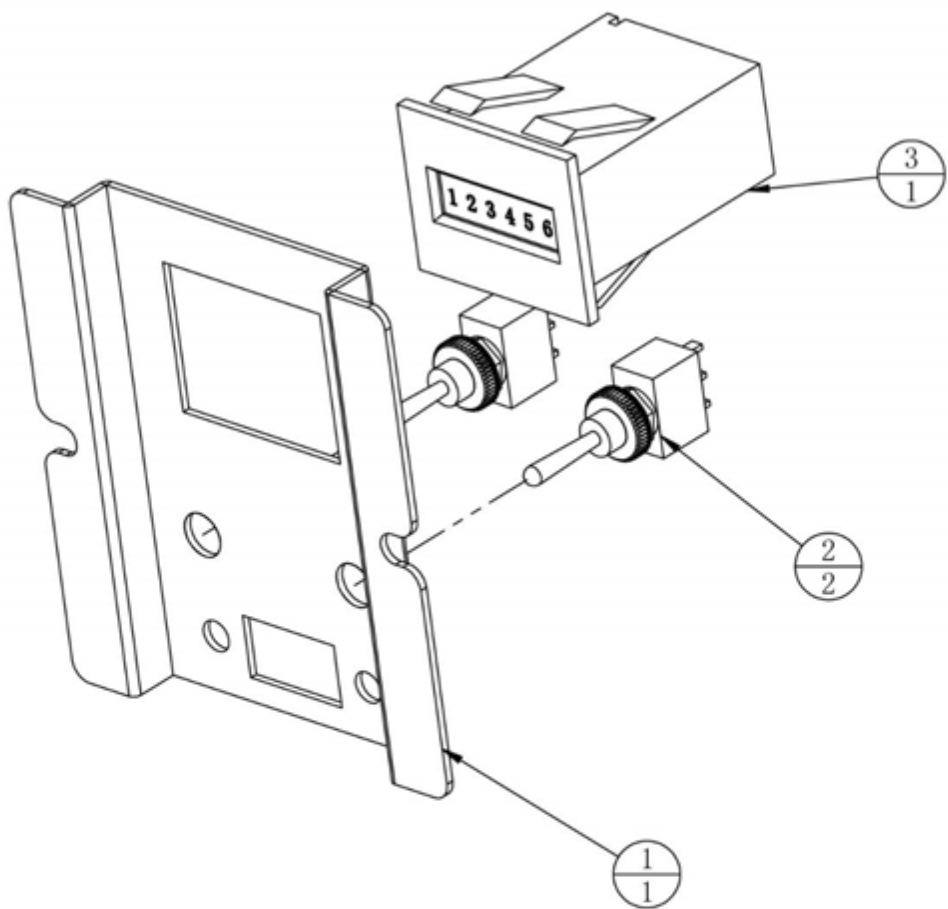

3	TMW-0210H03	Counter	OA-126CL	1	
2	TMW-0103H06	Button Switch	KNX123D-F0-Z2	2	
1	ATC-0119A01	Service plate	SECC-1.2T	1	
No.	Drawing No.	Name	Specification	Qty	Other

7.3.20 Rear End Assembly

29	ATC-0120D01	Tail light cover 1	PMMA	1	
28	ATC-0120D04	Tail light cover 2	PMMA	1	
27	ATC-0120D05	Tail light cover 3	PMMA-3.0T	1	
26	ATC-0120A02	Exhaust Manifold Bracket	AL	4	
25	ATC-0120C04	Exhaust Manifold Cover	ABS	2	
24	ATC-0120D02	Exhaust Manifold Cover	PMMA-3.0T	2	
23	ATC-0120A13	Rear back plate	SPCC-1.2T	1	
22	ATC-0120A10	Rear axle support bar	SPCC-1.5T	1	
21	ATC-0120A01	Tail Support Bracket	SPCC-2.0T	1	
20	ATC-0120C05	Brake cover	ABS	2	
19	ATC-0120A12	Wheel carrier	SPCC-1.2T	2	
18	ATC-0120C06	Left wheel hub	ABS	1	
17	ATC-0120A07	Wheel Spacer	AL	20	
16	ATC-0120H01	Wheel LED	SK6812 L=1380mm PU	2	
15	ATC-0120C01	Wheel	LDPE	2	
14	ATC-0120A08	Tail light pole	tube	1	
13	ATC-0120A09	Light pole fixing plate	SPCC-1.5T	2	
12	ATC-0120A15	Right baffle	SPCC-1.2T	1	
11	ATC-0120C02	Car Rear Molding	LDPE	1	
10	ATC-0120C03	Tailgate Cover	ABS	1	
9	ATC-0120A06	Tailgate	SPCC-1.2T	1	
8	ATC-0120A14	Left baffle	SPCC-1.2T	1	
7	ATC-0120A03	Rear Wing Pad		2	
6	ATC-0120A11	Rear upper plate	SPCC-1.5T	1	
5	ATC-0120A04	Rear Wing Pad	SPCC-2.0T	1	
4	ATC-0120A05	Tail light cover	SPCC-1.0T	1	
3	ATC-0120D03	Empennage	PMMA-8.0T	1	
2	ATC-0120D06	Wheel decoration	PMMA-3.0T	2	
1	ATC-0120C07	Right wheel hub	ABS	1	
No.	Drawing No.	Name	Specification	Qty	Other

7.4 65" Frame Assembly

65' Frame Assembly (1/2)

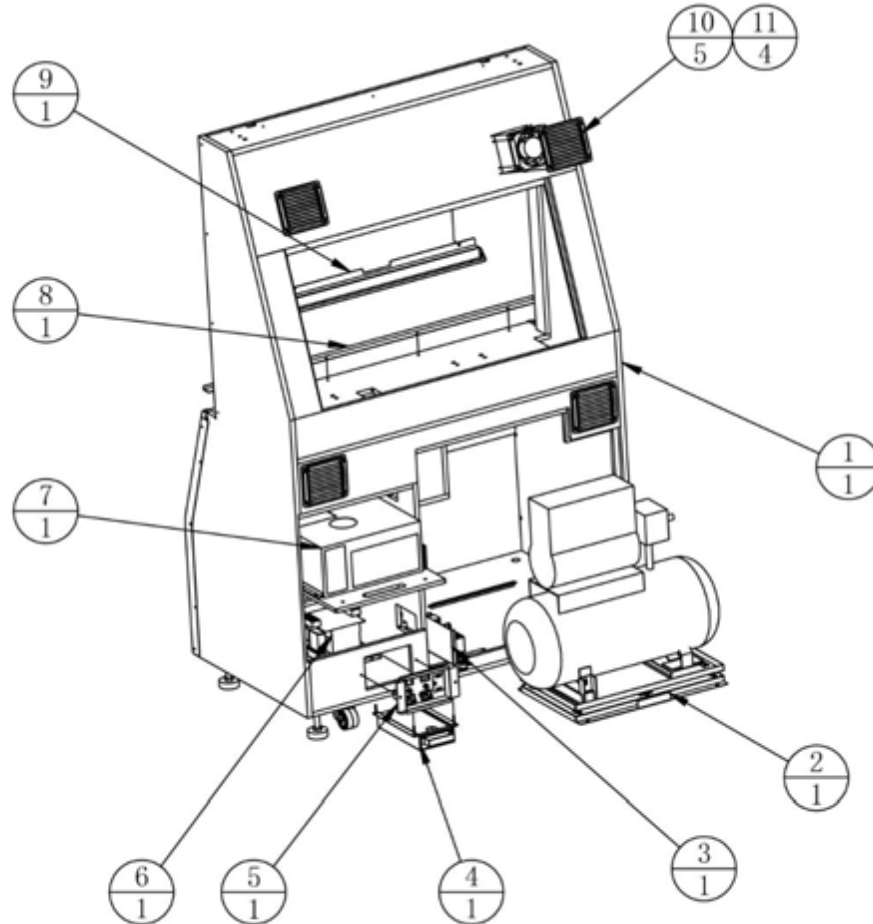

11	ATC-0209000	Fan assembly		4	
10	TMW-0302G01	Plastic Ventilation Net	253-5460	5	
9	ATC-0200A10	LCD Support Board	SPCC-1.5T	1	
8	ATC-0200A06	Glass lower plate	SPCC-1.2T	1	
7	ATC-0204000	Main unit assembly		1	
6	ATC-0206000	Transformer assembly		1	
5	ATC-0205000	Power switch assembly		1	
4	ATC-0215000	Sink assembly		1	
3	ATC-0214000	Filter assembly		1	
2	ATC-0202000	Air compressor assembly		1	
1	ATC-0201000	Wooden frame assembly		1	
No.	Drawing No.	Name	Specification	Qty	Other

65' Frame Assembly (2/2)

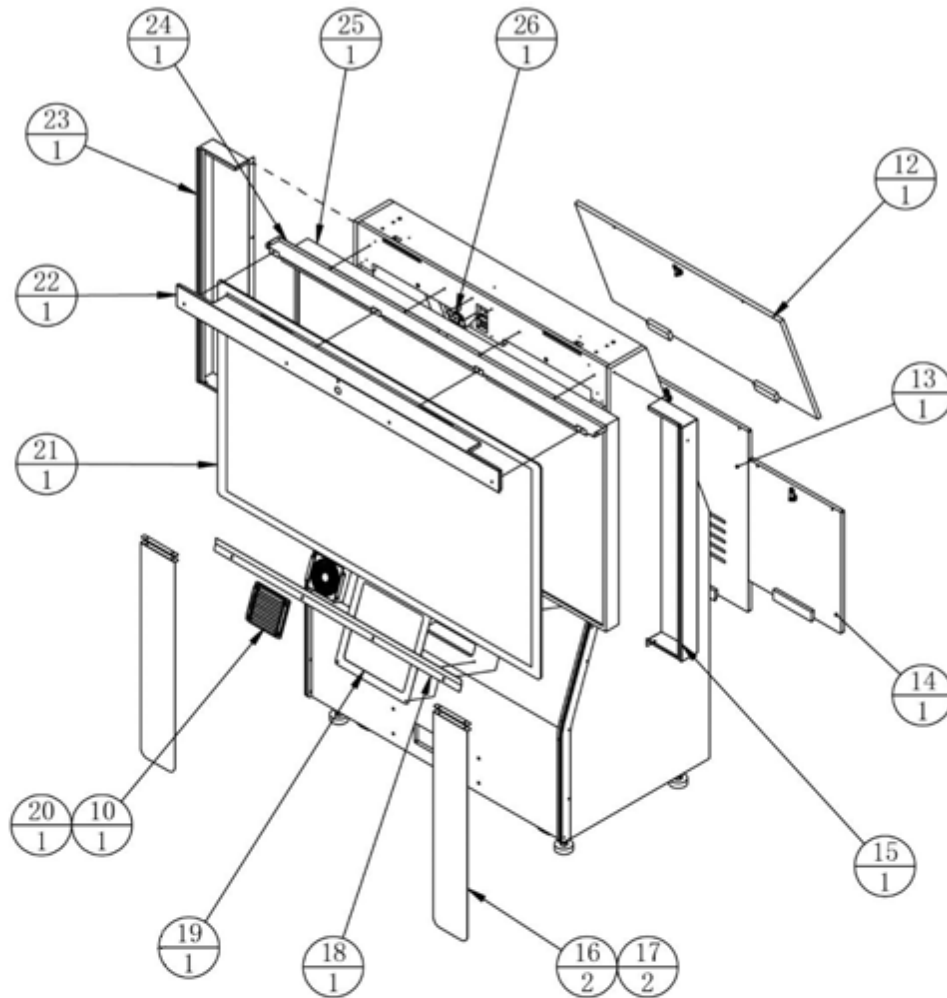

26	ATC-0213000	Camera Assembly		1	
25	ATC-0216000	65" LCD Assembly		1	
24	ATC-0200A07	Glass upper plate	SPCC-1.2T	1	
23	ATC-0200A04	LCD left frame	SPCC-1.2T	1	
22	ATC-0200A02	LCD upper frame	SPCC-1.5T	1	
21	ATC-0200C01	Monitor Glass	Glass-5.0T	1	
20	ATC-0210000	Intake fan assembly		1	
19	ATC-0200A01	Woofer net	Net	1	
18	ATC-0200A08	Glass Platen Lower	SPCC-1.2T	1	
17	ATC-0200A09	Side flag boards	SPCC-1.2T	2	
16	ATC-0200D02	lower side flag	cloth	2	
15	ATC-0200A03	LCD right frame	SPCC-1.2T	1	
14	ATC-0208000	PC door assembly		1	
13	ATC-0207000	Air compressor door assembly		1	
12	ATC-0211000	LCD door assembly		1	
No.	Drawing No.	Name	Specification	Qty	Other

7.4.1 Wooden Frame Assembly

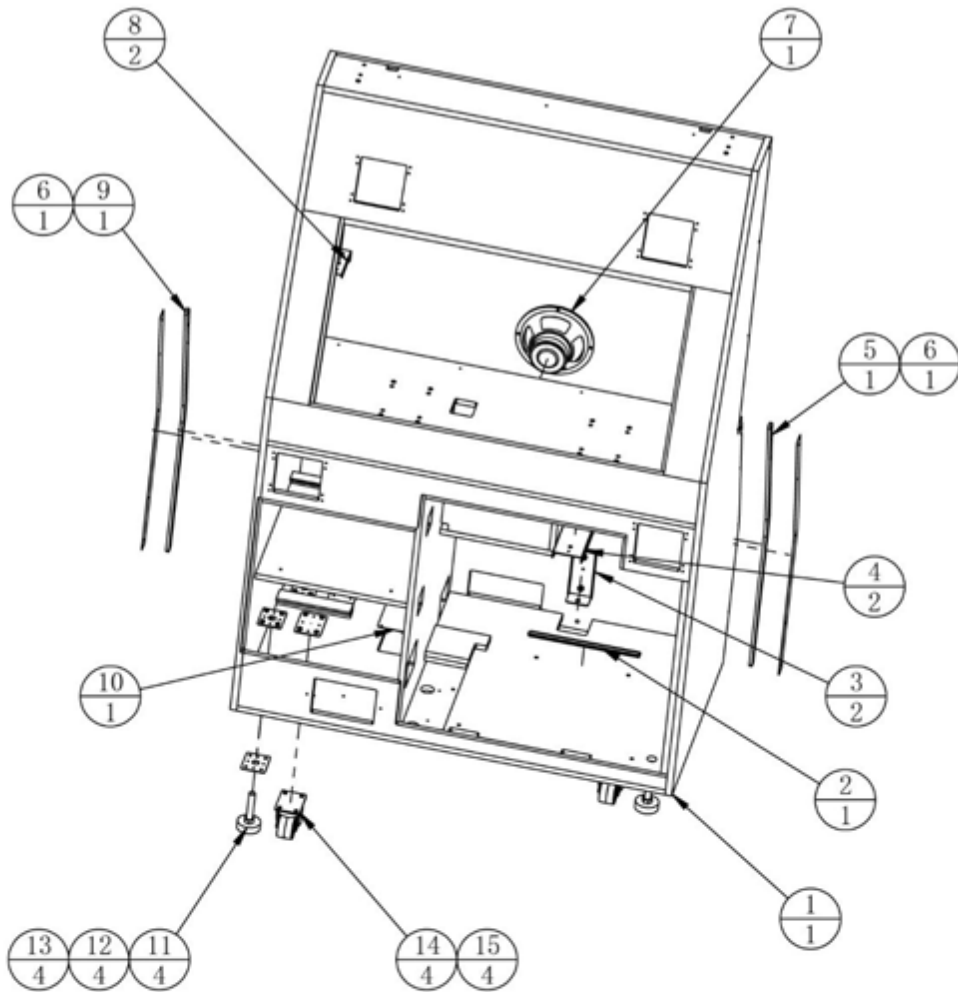

15	ATV-0201A06	Caster fixing iron	SPCC-2.0T	4	
14	TMW-0101G01	Movable casters	2.5"	4	
13	ATV-0201A05	Foundation Bolt Plate	SPCC-2.0T	4	
12	ATV-0201A07	Foundation Bolt Fixing Plate	SPCC-2.0T	4	
11	TMW-0102G01	Ground Screw (Rubber Bottom)	M16*100	4	
10	ATC-0201A01	Plastic Ventilation Net	Net	1	
9	ATC-0201D01	LCD Right Side Panel	PMMA-8.0T	1	
8	ATC-0201A08	Light box plate	SECC-1.5T	2	
7	TMW-0401H08	Woofer	8' 4Ω/200W	1	
6	ATC-0201A07	LCD side cover	SPCC-1.2T	2	
5	ATC-0201D02	LCD Left Side Panel	PMMA-8.0T	1	
4	ATC-0201A03	LCD Reinforcement plate	SECC-2.0T	2	
3	ATC-0201A06	Frame connecting plate	SPCC-2.0T	2	
2	ATC-0201A02	Air compressor limit plate	SECC-1.5T	1	
1	ATC-0201B01	LCD frame		1	
No.	Drawing No.	Name	Specification	Qty	Other

7.4.2 Air Compressor Assembly

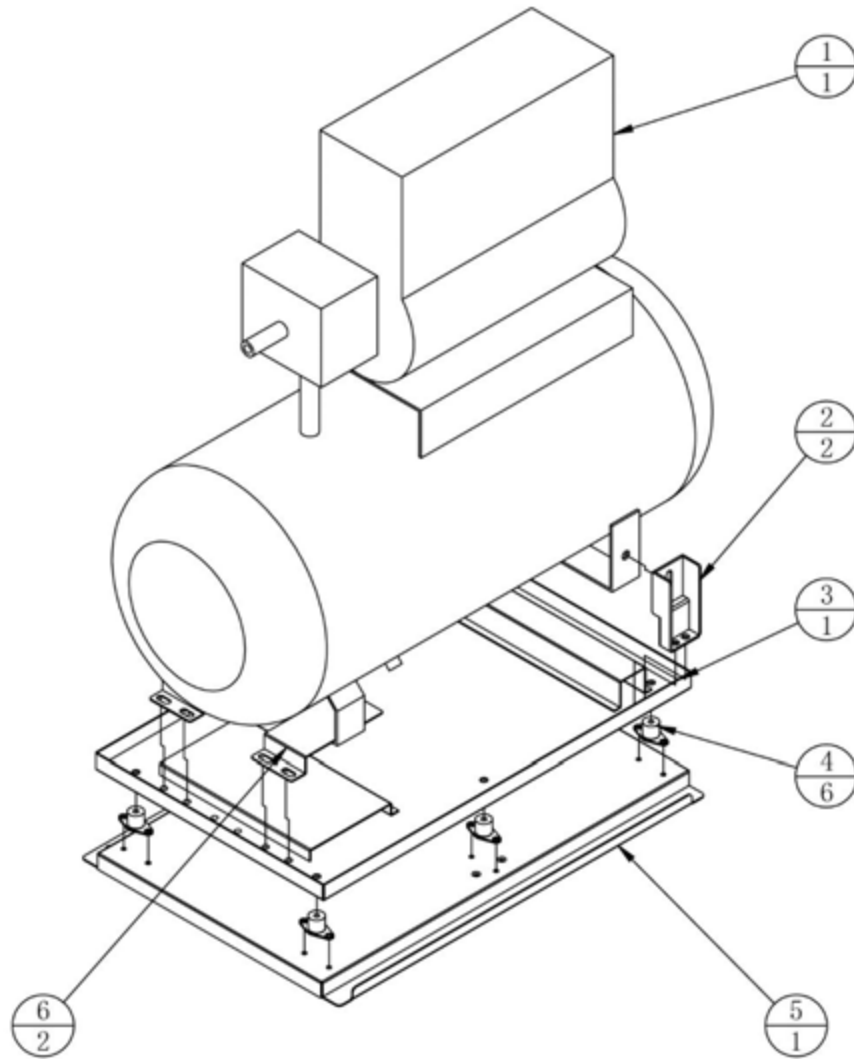

6	ATC-0202A03	Air Compressor Pressure Iron	SPCC-1.5T	2	
5	ATC-0202A01	Air Compressor Shockproof Base		1	
4	TMW-0102G02	Marquee Type Anti-Vibration Feet		6	
3	ATC-0202A02	Air Compressor Support Base		1	
2	ATC-0202A04	Air Compressor Fixed Iron	SPCC-2.5T	2	
1	TMW-0206H01	Compressor	S10	1	
No.	Drawing No.	Name	Specification	Qty	Other

7.4.3 Main Unit Assembly

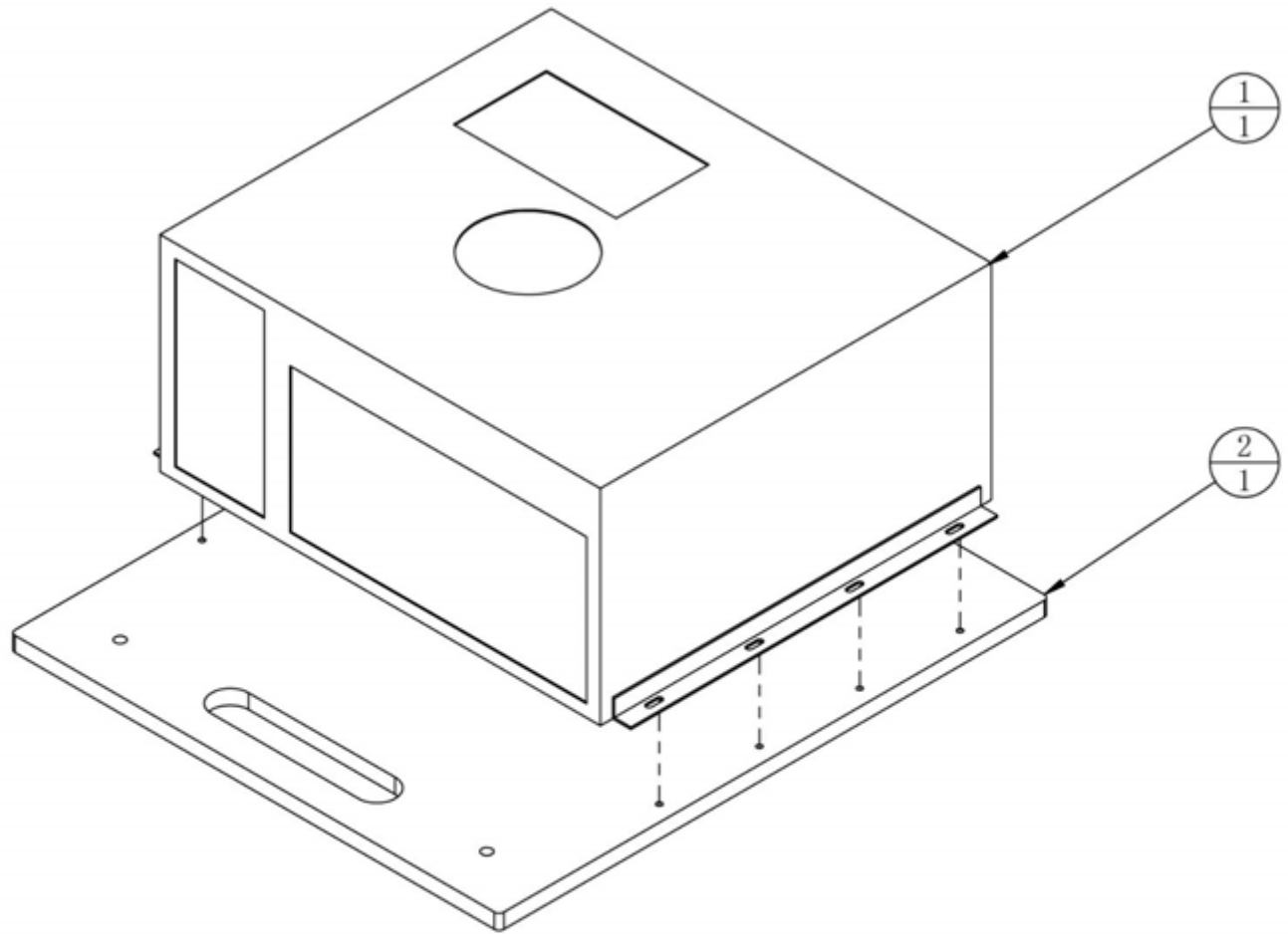

2	ATC-0204B01	PC Fixing Plate	MDF-15.0T	1	
1	ATC-0204H01	PC		1	
No.	Drawing No.	Name	Specification	Qty	Other

7.4.4 Power Switch Assembly

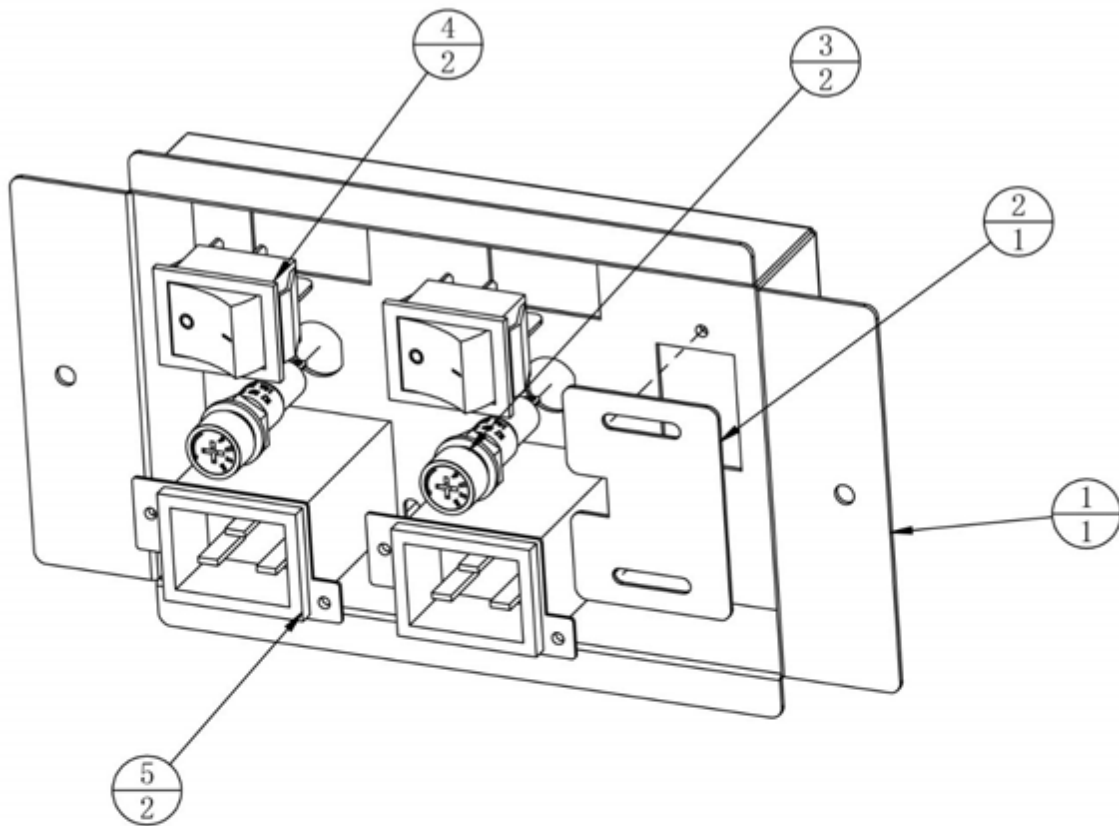

5	TMW-0105H02	Filter	YMA20A1	2	
4	TMW-0103H01	Boat-shape Switch	4P KCD7-2211N	2	
3	TMW-0104H01	Fuse Cartridge	MF527A (6*30)	2	
2	ATC-0205A02	Cable Cover	SPCC-1.0T	1	
1	ATC-0205A01	AC Power Box	SPCC-1.2T	1	
No.	Drawing No.	Name	Specification	Qty	Other

7.4.5 Transformer Assembly

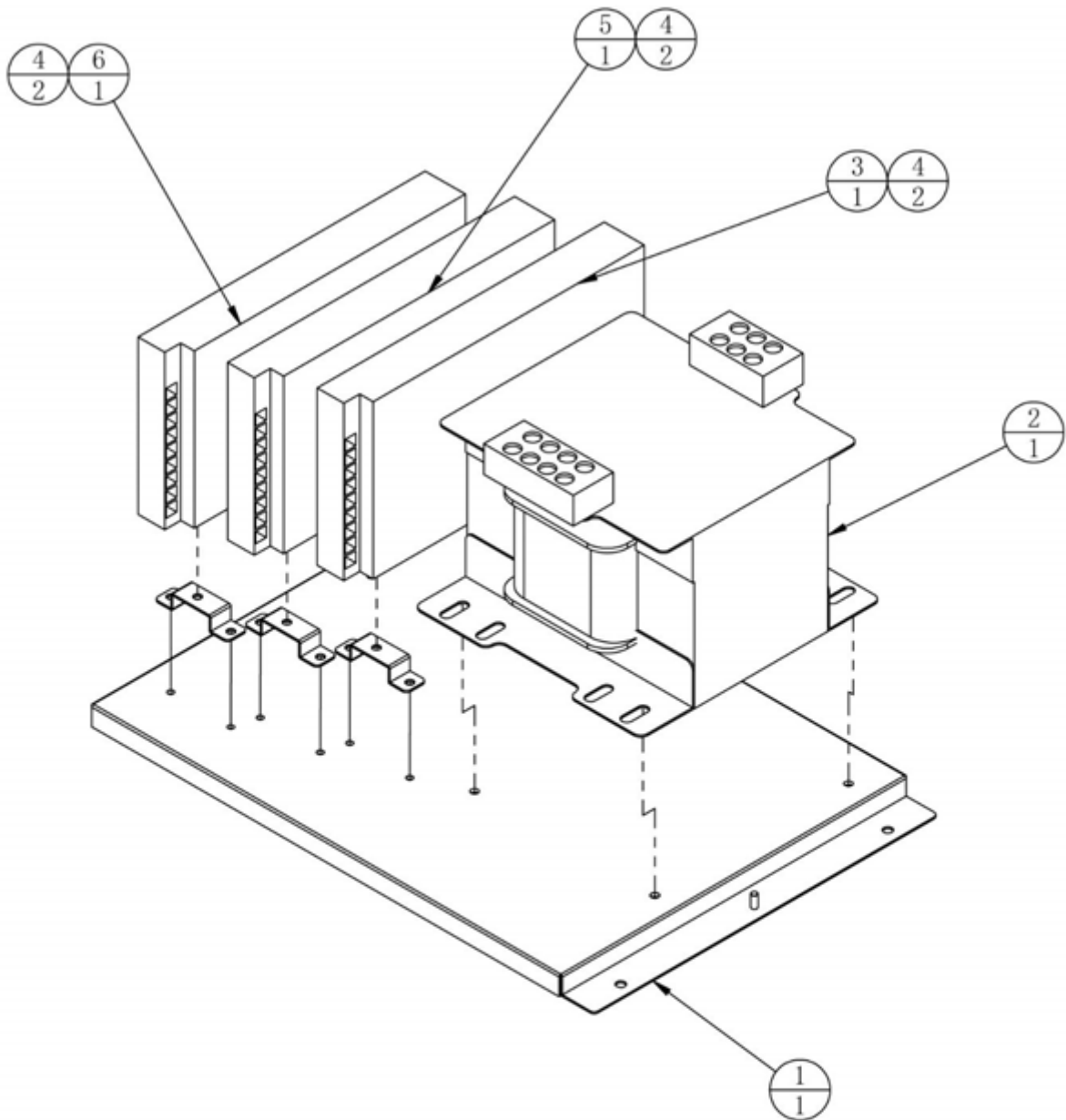

6	TMW-0102H04	Power box 5V	LRS-350-5	1	
5	TMW-0102H02	Power box 24V	LRS-350-24	1	
4	ATC-0206A02	Power Box Fixing Plate	SECC-1.2T	6	
3	TMW-0102H01	Power box 12V	LRS-350-12	1	
2	TMW-0101H04	Transformer	HL162-16-110/35	1	
1	ATC-0206A01	Transformer fixing plate	SECC-1.2T	1	
No.	Drawing No.	Name	Specification	Qty	Other

7.4.6 Air Compressor Door Assembly

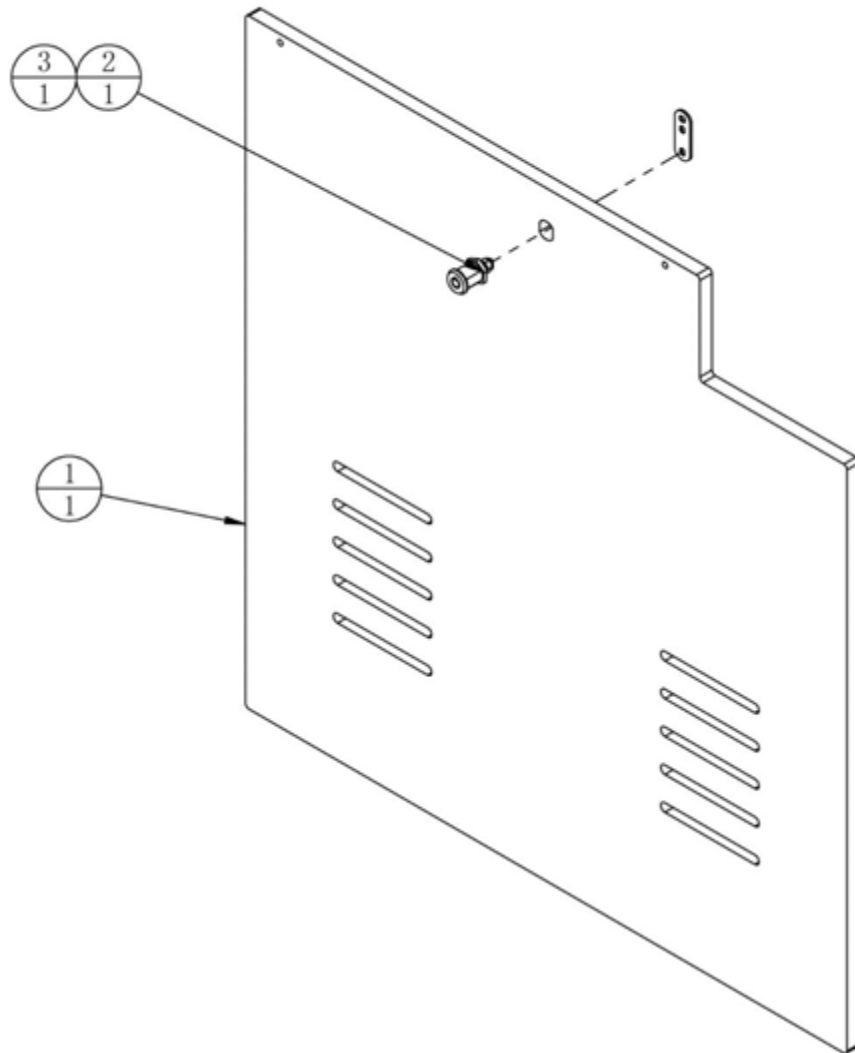

3	TMW-0203G03	Lock tab	5cm(004)	1	
2	TMW-0201G01	lock	5555-K	1	
1	ATC-0207B01	Air compressor door	MDF-15.0T	1	
No.	Drawing No.	Name	Specification	Qty	Other

7.4.7 PC Door Assembly

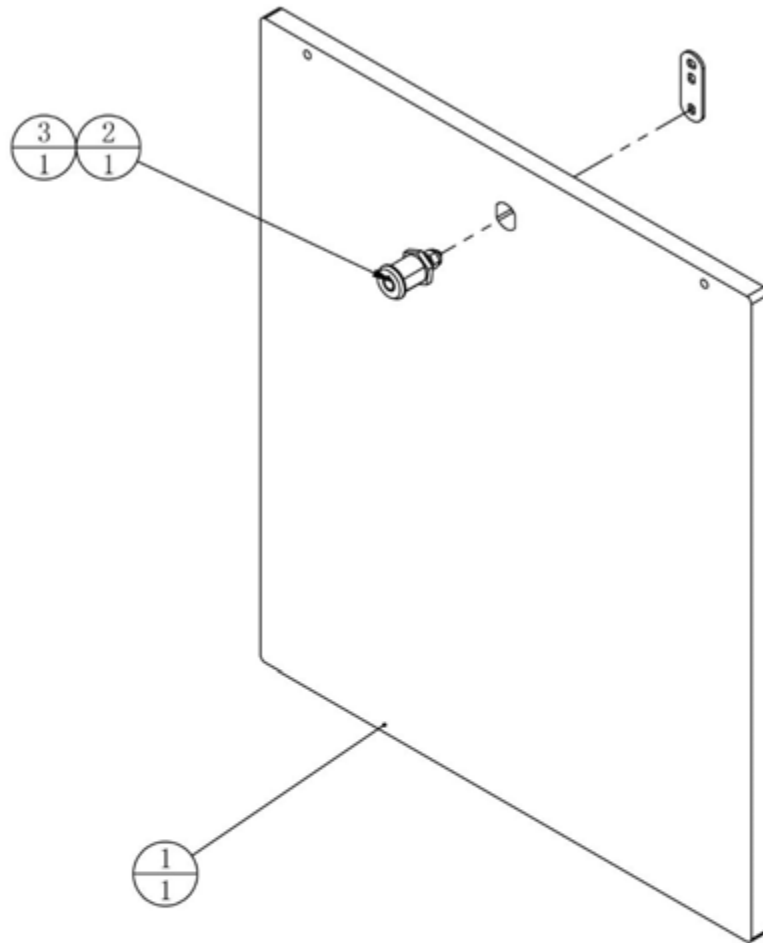

3	TMW-0203G03	Lock tab	5cm(004)	1	
2	TMW-0201G01	Lock	5555-K	1	
1	ATC-0208B01	PC Door	MDF-15.0T	1	
No.	Drawing No.	Name	Specification	Qty	Other

7.4.8 Fan Assembly

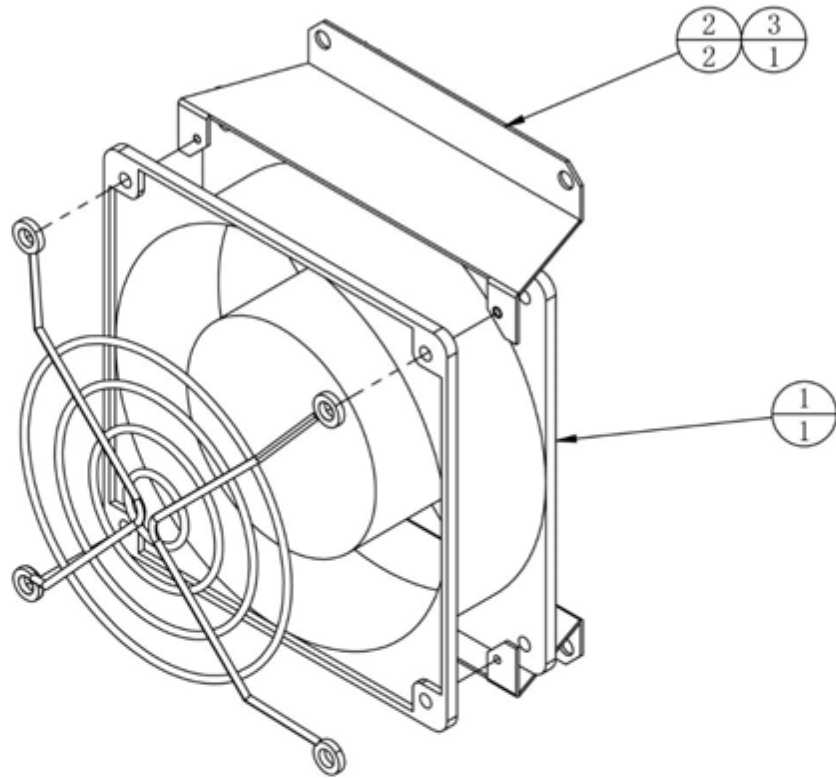

3	TMW-0202H01-01	FAN NET	120*120	1	
2	ATC-0209A01	Fan frame	SECC T-1.0	2	
1	TMW-0202H01	FAN	GD 12038H24B-A01	1	
No.	Drawing No.	Name	Specification	Qty	Other

7.4.9 Intake Fan Assembly

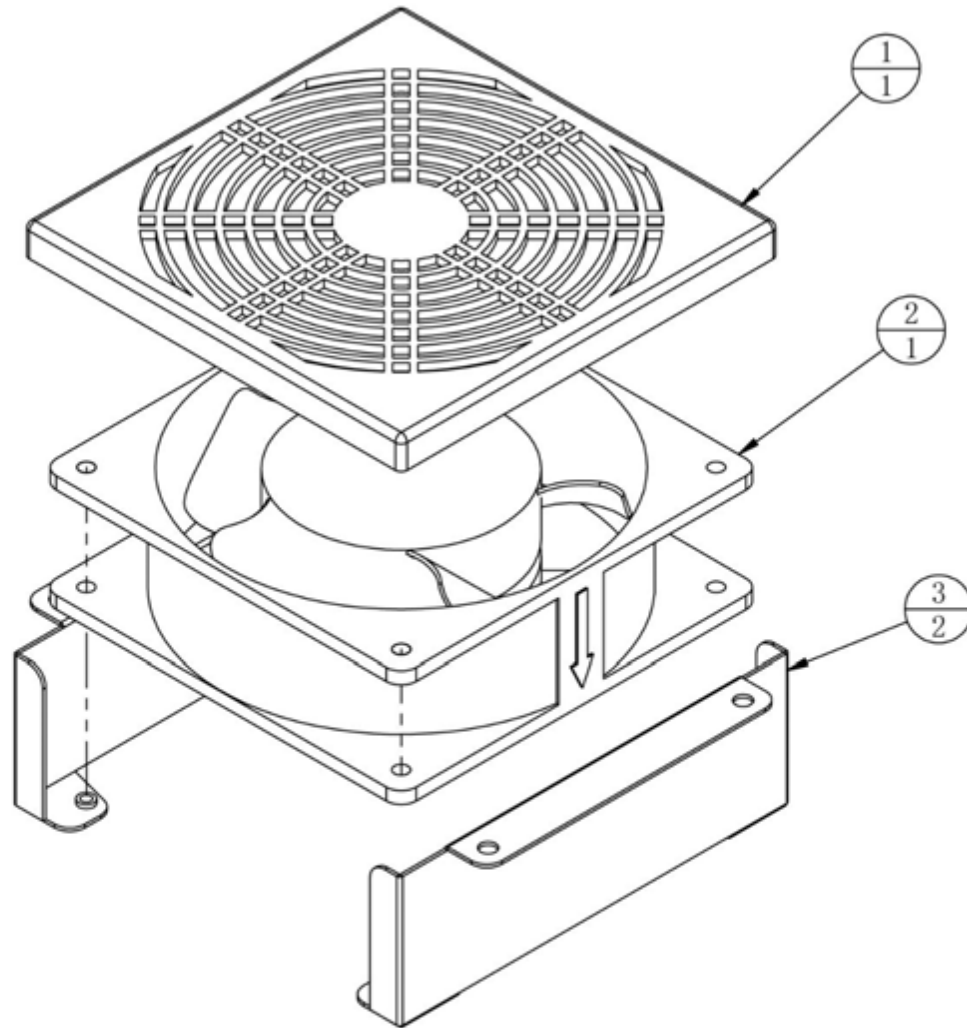

3	ATC-0210A01	Fan fixing plate	SPCC-1.2T	2	
2	TMW-0202H01	FAN	SD1238M2B DC24V 0.35A	1	
1	TMW-0302G02	Dust proof		1	
No.	Drawing No.	Name	Specification	Qty	Other

7.4.10 LCD Door Assembly

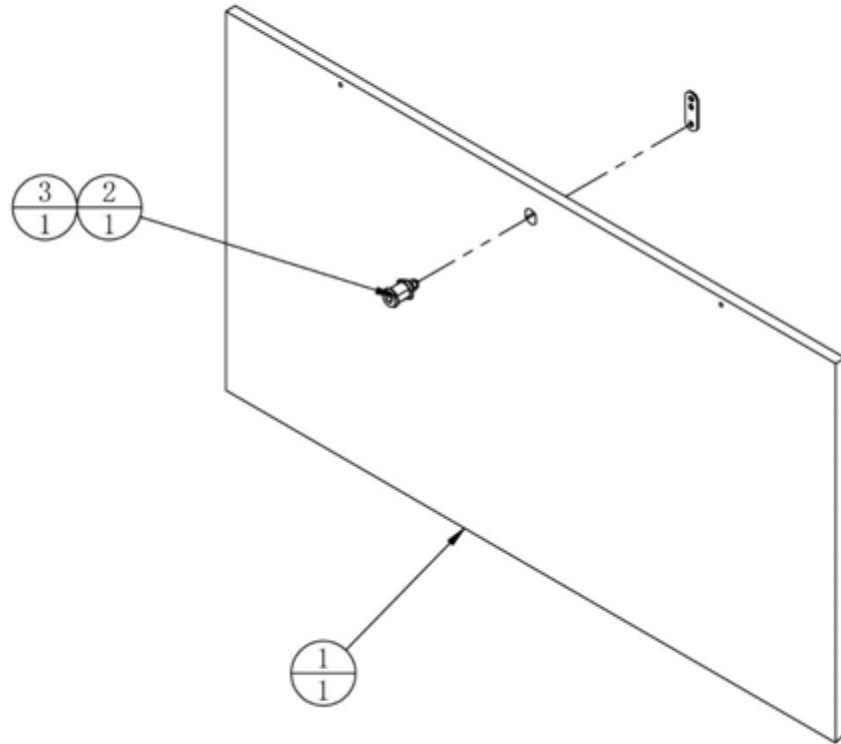

3	TMW-0203G03	Lock tab	5cm(004)	1	
2	TMW-0201G01	Lock	5555-K	1	
1	ATC-0211B01	LCD Door	MDF-15.0T	1	
No.	Drawing No.	Name	Specification	Qty	Other

7.4.11 Camera Assembly

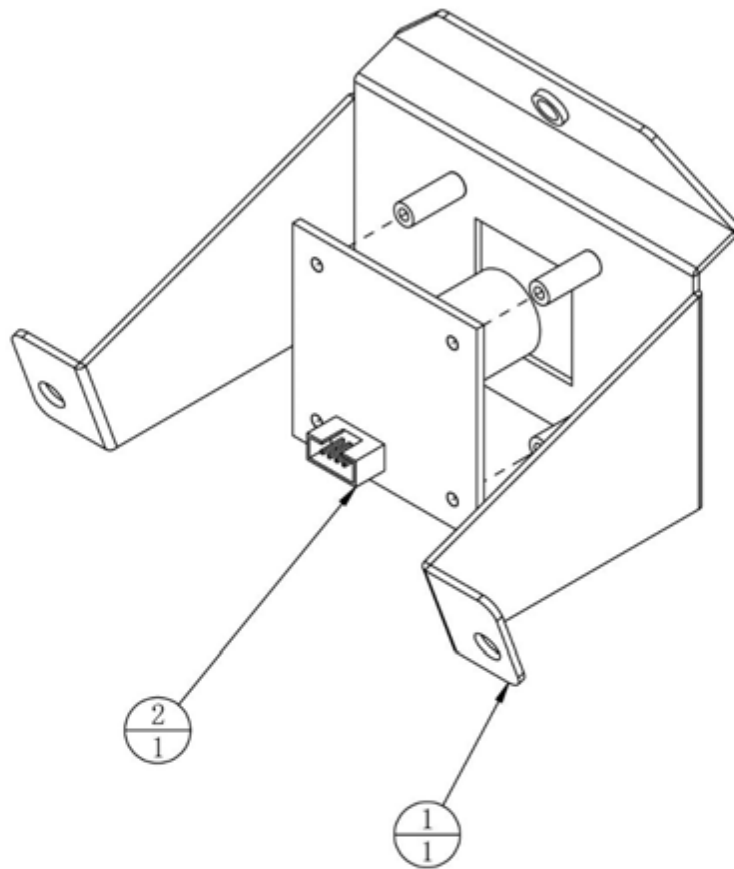

2	TMW-0210H01	Camera	ELP-USBFHD01M-L36	1	
1	ATC-0213A01	Camera fixing plate	SPCC-1.2T	1	
No.	Drawing No.	Name	Specification	Qty	Other

7.4.12 Filter Assembly

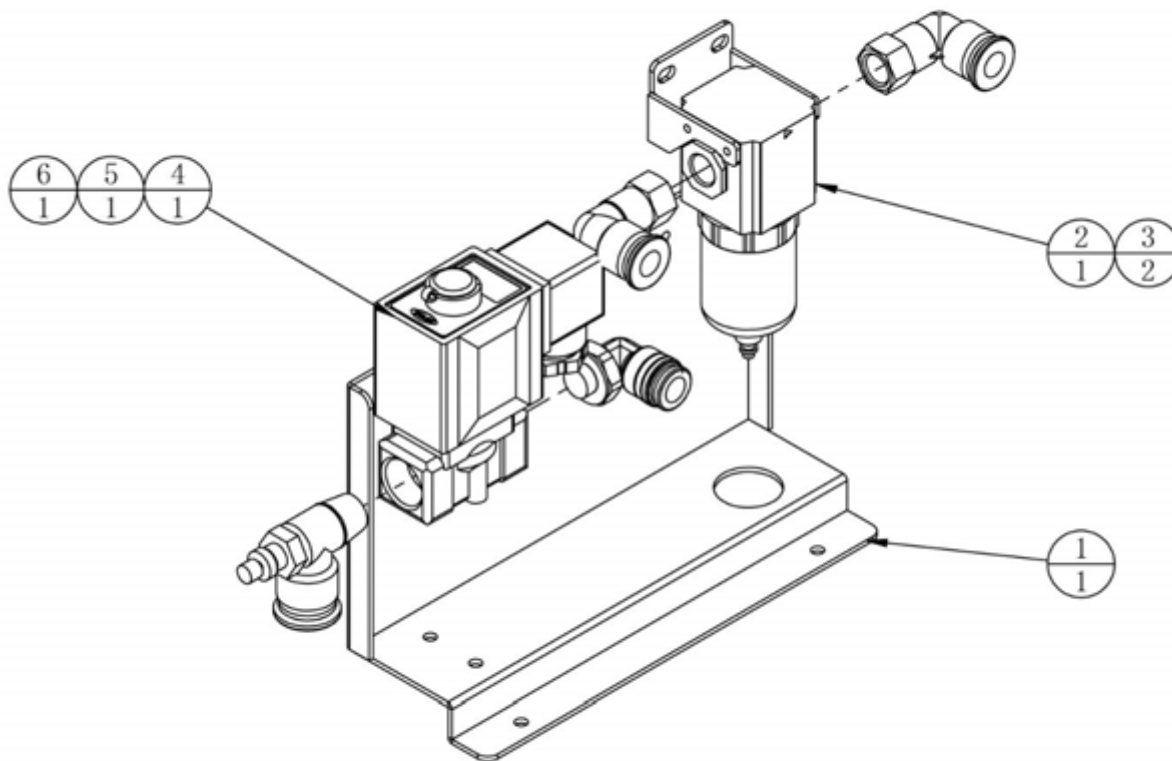

6	TMW-0404G23	L-type threaded 2-way	APL10-04	1	
5	TMW-0701H06	Pipe-connected Check Throttle	ASL10-04B	1	
4	TMW-0701H05	Fluid Control Valve	2KW050-15-F	1	
3	TMW-0404G21	L-type threaded 2-way	APL10-02	2	
2	TMW-0401G02	Gas Source Processing Component	GF200-08	1	
1	ATC-0214A01	Filter plate	SPCC-2.0T	1	
No.	Drawing No.	Name	Specification	Qty	Other

7.4.13 Sink Assembly

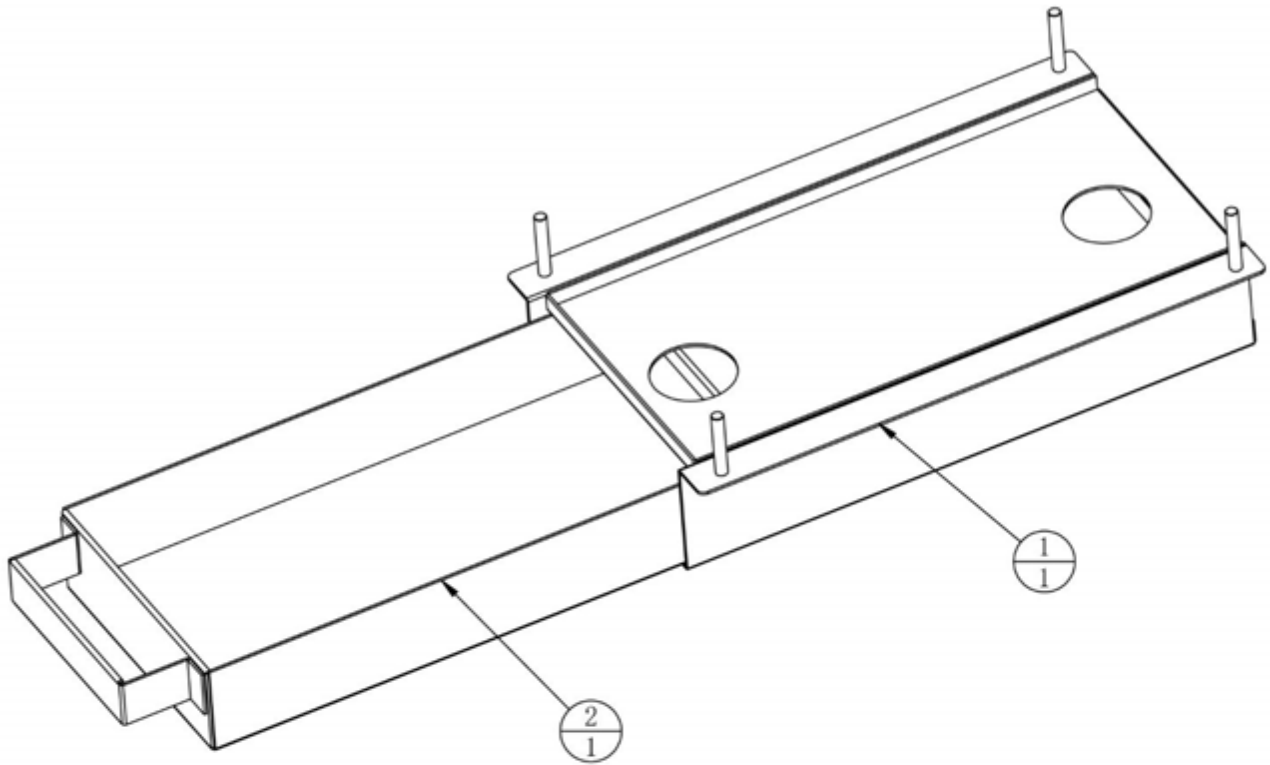

2	ATC-0215A02	Sink		1	
1	ATC-0215A01	Sink Fixing Plate		1	
No.	Drawing No.	Name	Specification	Qty	Other

7.4.14 65" LCD Assembly

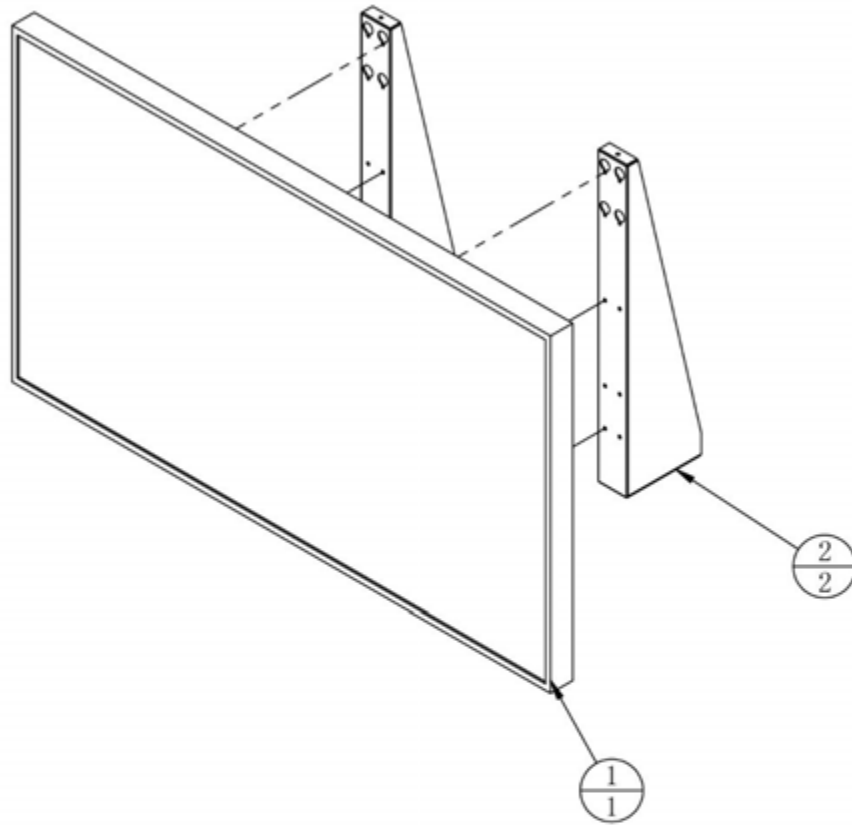

2	ATC-0203A01	LCD Monitor Fixing Plate	SPCC-2.5T	2	
1	TMW-0201H05	Monitor	65 inch	1	
No.	Drawing No.	Name	Specification	Qty	Other

7.5 LCD Panel Assembly

LCD Pabel Assembly

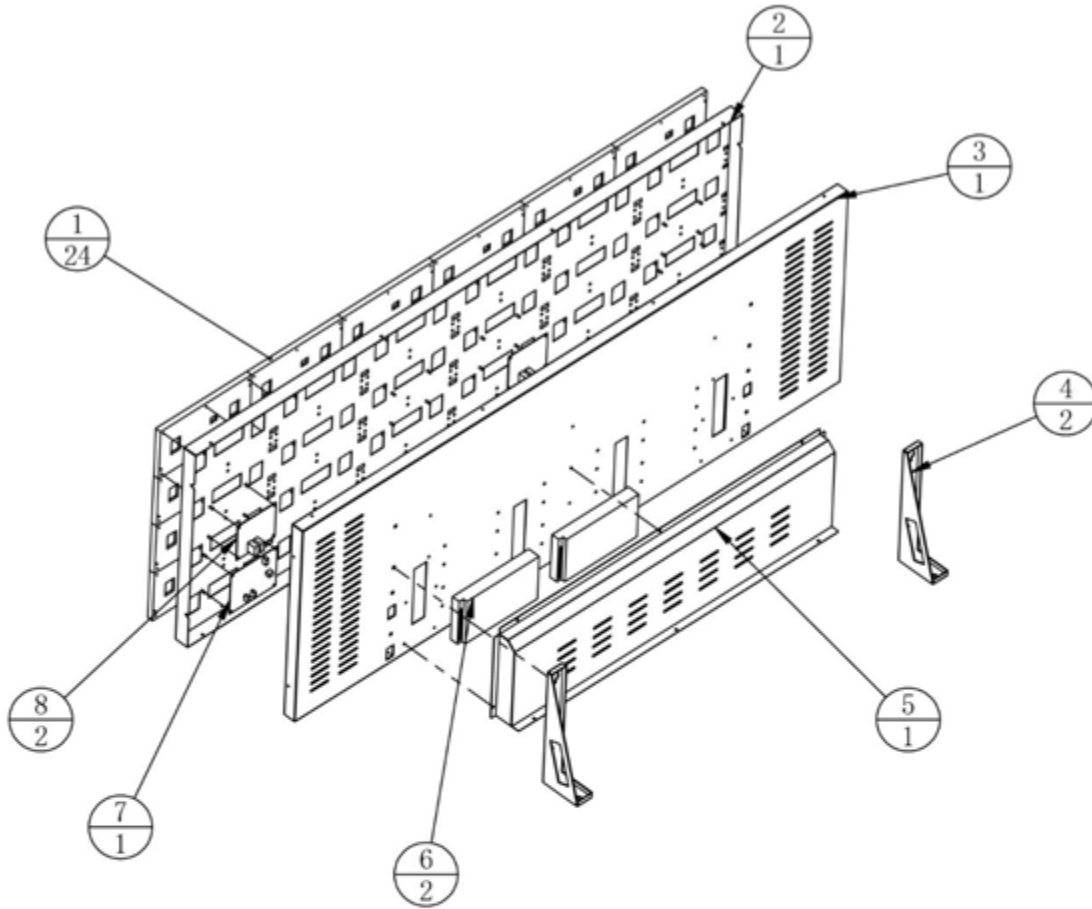

8	TMW-0801H03	Receiver Card		2	
7	TMW-0801H02	Transmitter Card	With HDMI port	1	
6	TMW-0102H04	Power box 5V	LRS-350-5	2	
5	ATC-0300A03	LED Panel rear cover	SPCC-1.0T	1	
4	ATC-0300A02	Light box bracket	SPCC-2.0T	2	
3	ATC-0300A04	LED Panel support plate	SPCC-1.2T	1	
2	ATC-0300A01	LED Panel Plate	SPCC-1.2T	1	
1	TMW-0801H01	LED Panel	MY-UDF-PH4	24	
No.	Drawing No.	Name	Specification	Qty	Other

8. Printing Pattern

8.1 Printing Pattern of Cabinet



9. Wiring Diagram

9. Wiring Diagram 6 pages

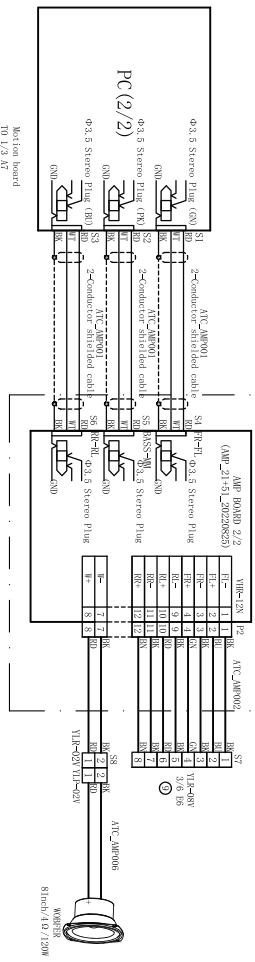
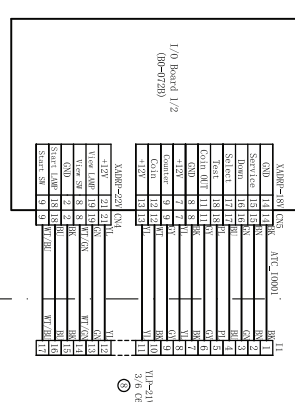
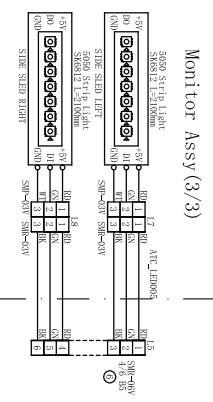
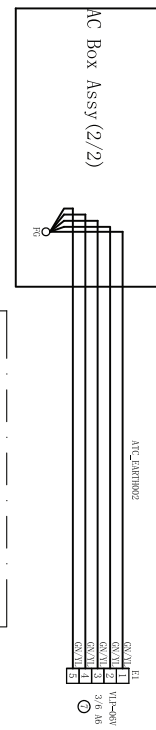

CHINESE	ENGLISH	ENGLISH ABBREVIATED	CHINESE	ENGLISH	ENGLISH ABBREVIATED	CHINESE	ENGLISH	ENGLISH ABBREVIATED
黑	BLACK	BR	粉紫	PINK	PK	白紫	WHITE PURPLE	WT/P
棕	BROWN	BN	白粉紫	WHITE PINK	WT/PK	白紫	WHITE PURPLE	WT/P
绿	GREEN	GN	白粉紫	WHITE PINK	WT/PK	白紫	WHITE PURPLE	WT/P
黄	YELLOW	YL	白粉紫	WHITE PINK	WT/PK	白紫	WHITE PURPLE	WT/P
蓝	BLUE	BL	白粉紫	WHITE PINK	WT/PK	白紫	WHITE PURPLE	WT/P
紫	PURPLE	PL	白粉紫	WHITE PINK	WT/PK	白紫	WHITE PURPLE	WT/P
灰	GRAY	GY	白粉紫	WHITE PINK	WT/PK	白紫	WHITE PURPLE	WT/P
白	WHITE	WT	白粉紫	WHITE PINK	WT/PK	白紫	WHITE PURPLE	WT/P

Air Inflation Elec Valve Assy

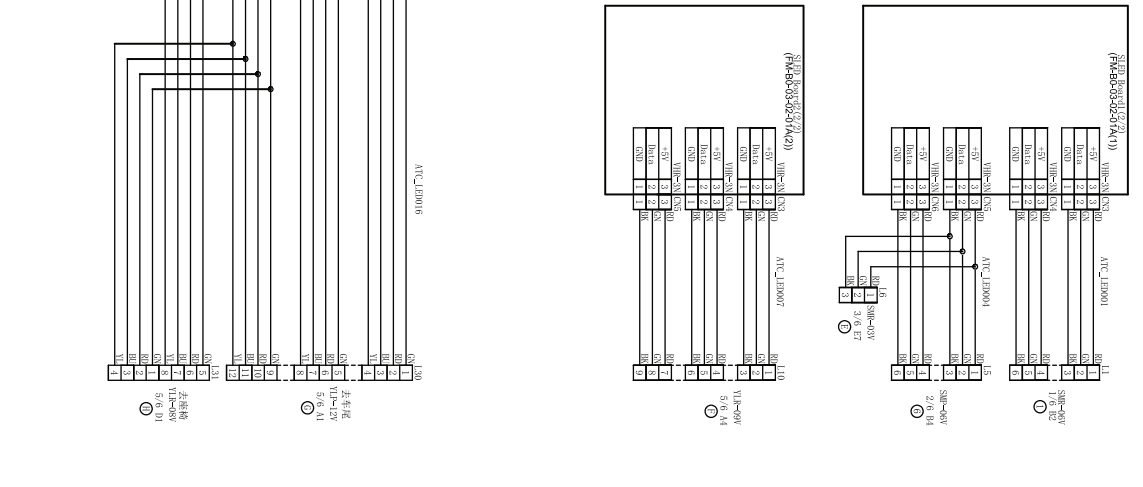
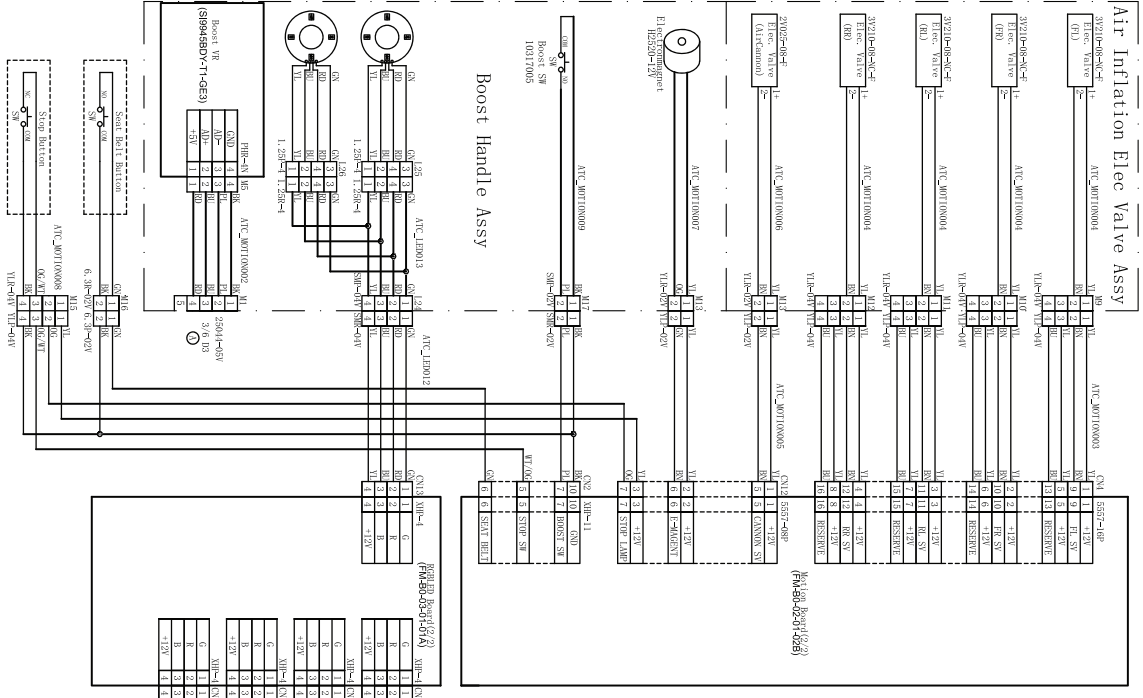

CHINESE	ENGLISH	ENGLISH ABBREVIATED	CHINESE	ENGLISH	ENGLISH ABBREVIATED	CHINESE	ENGLISH	ENGLISH ABBREVIATED																										
黑	BLACK	BLK	粉紅	PINK	PK	白綠	WHITE GREEN	WT/GS																										
棕	BROWN	BN	白	WHITE	WT	白	WHITE	WT																										
紅	RED	RD	白綠	WHITE GREEN	WT/GS	白	WHITE	WT																										
藍	BLUE	BLU	白	WHITE	WT	白	WHITE	WT																										
黃	YELLOW	YL	白	WHITE	WT	白	WHITE	WT																										
綠	GREEN	GN	白	WHITE	WT	白	WHITE </tr <tr> <td>紫</td> <td>PURPLE</td> <td>PL</td> <td>白</td> <td>WHITE</td> <td>WT</td> <td>白</td> <td>WHITE</td> <td>WT</td> </tr> <tr> <td>灰</td> <td>GRAY</td> <td>GY</td> <td>白</td> <td>WHITE</td> <td>WT</td> <td>白</td> <td>WHITE</td> <td>WT</td> </tr> <tr> <td>白</td> <td>WHITE</td> <td>WT</td> <td>白</td> <td>WHITE</td> <td>WT</td> <td>白</td> <td>WHITE</td> <td>WT</td> </tr>	紫	PURPLE	PL	白	WHITE	WT	白	WHITE	WT	灰	GRAY	GY	白	WHITE	WT	白	WHITE	WT	白	WHITE	WT	白	WHITE	WT	白	WHITE	WT
紫	PURPLE	PL	白	WHITE	WT	白	WHITE	WT																										
灰	GRAY	GY	白	WHITE	WT	白	WHITE	WT																										
白	WHITE	WT	白	WHITE	WT	白	WHITE	WT																										

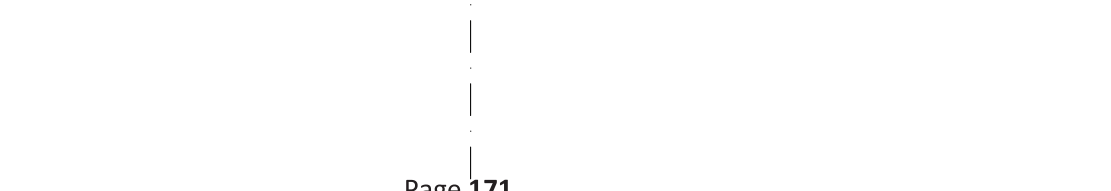
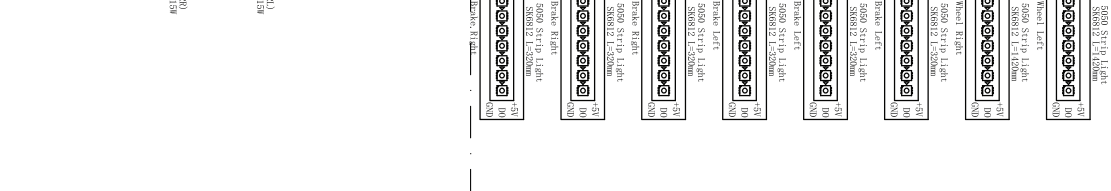
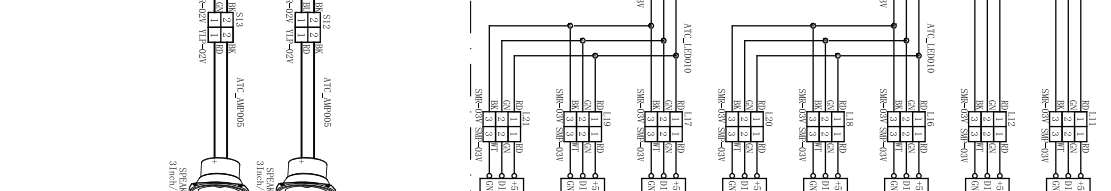
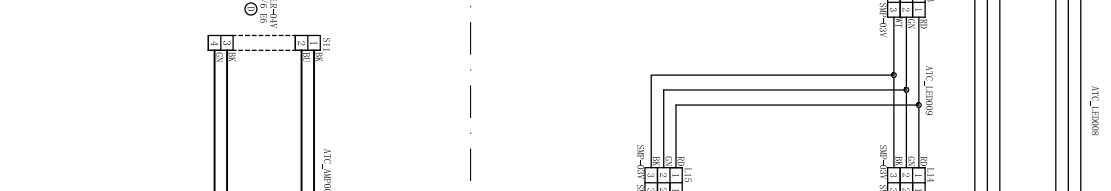
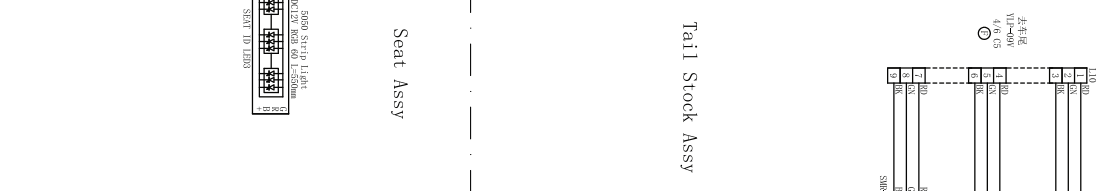
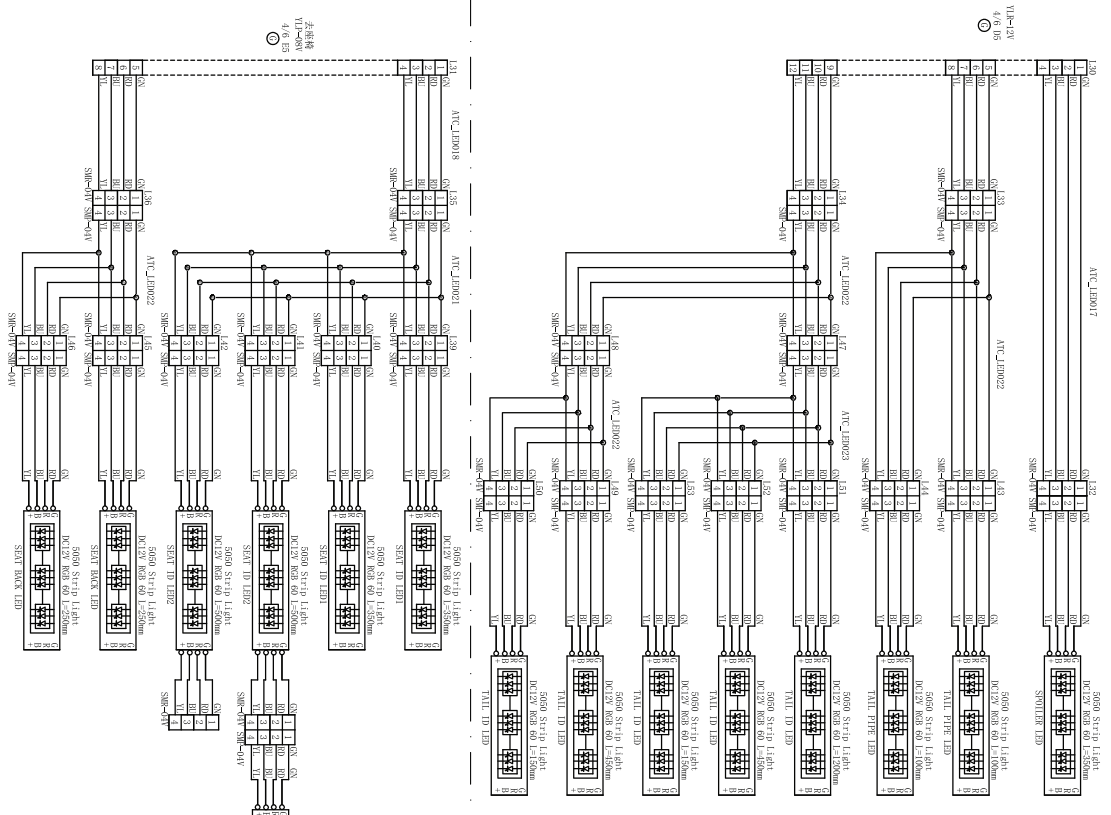

Seat Assy

Tail Stock Assy

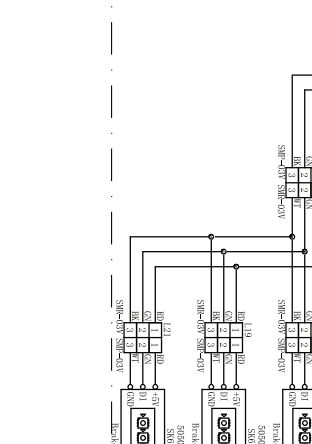
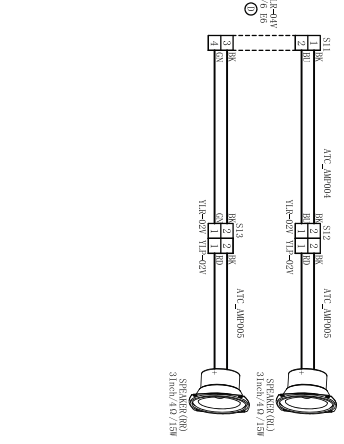

CHINESE	ENGLISH	ENGLISH ABBREVIATED	CHINESE	ENGLISH	ENGLISH ABBREVIATED	CHINESE	ENGLISH	ENGLISH ABBREVIATED
黑	BLACK	BK	粉	PINK	PK	白	WHITE	WT
棕	BROWN	BN	浅粉	LIGHT PINK	LIPK	白	WHITE	WT
红	RED	RD	浅绿	LIGHT GREEN	LIGN	白	WHITE	WT
黄	YELLOW	YL	浅黑	WHITE BLACK	WTBK	白	WHITE	WT
绿	GREEN	GN	浅蓝	WHITE LIGHT BLUE	WTLTBL	白	WHITE	WT
蓝	BLUE	BL	浅黄	WHITE YELLOW	WTYLW	白	WHITE	WT
灰	GRAY	GR	浅紫	WHITE PURPLE	WTPUR	白	WHITE	WT
白	WHITE	WT	浅紫	WHITE PURPLE	WTPUR	白	WHITE	WT

LED Panel Assy (2/2)

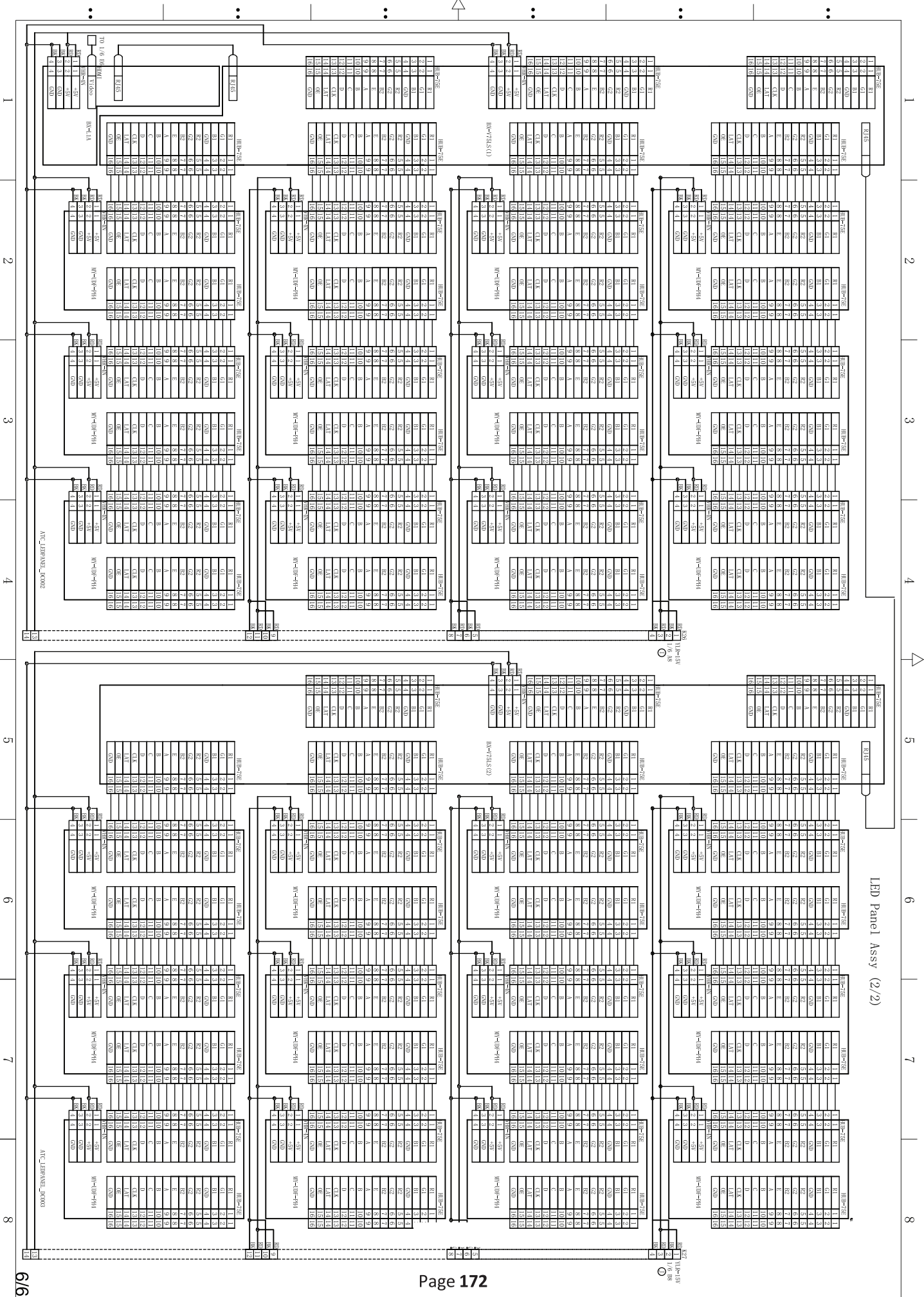

10. Spares and Service Contact Information

Sega Amusements International

42 Barwell Business Park
Leatherhead Road,
Chessington,
Surrey,
KT9 2NY
United Kingdom

Parts: +44 (0) 2083918060
stssales@segaarcade.com

- TECHNICAL SUPPORT -

+44 (0) 2083918060
technical@segaarcade.com

- PLAY IT AMUSEMENTS -

870 Lively Blvd
Wood Dale,
IL,
602191
United States of America

Parts/Customer Service: +00 (1) 224 265 4287
Technical Support: +00 (1) 224 265 4283
PIA: support@playitamusements.com





APEX REBELS MOTION

USER MANUAL

Ver. 1.04



*The specifications and operation instructions in this Manual are subject to change without notice for reasons such as performance.