



OPERATION MANUAL



IMPORTANT

- Before using this product, read this Manual carefully to understand the contents herein stated
- After reading this Manual, be sure to keep it near the product or in a convenient place for easy reference when necessary

BEFORE USING THE PRODUCT, BE SURE TO READ THE FOLLOWING:

TO MAINTAIN SAFETY:

To ensure the safe operation of this product, be sure to read the following before usage:

The following instructions are intended for the users, operators and the personnel in charge of the operation of the product. After carefully reading and sufficiently understanding the warning displays and cautions, handle the product appropriately. Be sure to keep this manual close to the product or in a convenient place for future reference.

Herein, explanations which require special attention are enclosed with dual lines. Depending on the potentially hazardous degrees, the terms of "**DANGER**", "**WARNING**", "**CAUTION**", etc. are used.

Be sure to understand the contents of the displays before reading the text.

PICTOGRAPHS AND DEFINITIONS

 **DANGER** Indicates that mishandling the product by disregarding this pictograph will cause severe injury or death.

 **WARNING** Indicates that mishandling the product by disregarding this warning will cause a potentially hazardous situation which can result in death or serious injury.

 **CAUTION** Indicates that mishandling the product by disregarding this caution will cause a slight hazardous situation which can result in personal injury and/or material damage.

For the safe usage of the product, the following pictographs are used:



Indicates "**HANDLE WITH CARE.**" In order to protect the human body and equipment, this display is attached to places where the instruction manual should be referred to



Indicates a "**protective earth terminal.**" Before operating the equipment, be sure to connect it to the ground (this step may be omitted for products in which a power cable with earth is used)

- **Perform work in accordance with the instructions herein stated:**
Instructions for work are explained by paying attention to the aspect of accident prevention. Failing to perform work as per the instructions can cause accidents. In the case where only those who have technical expertise should perform the work to avoid hazardous situation, the instructions herein state that the site maintenance personnel should perform such work
- **Be sure to turn off the power before working on the machine:**
To prevent an electric shock, be sure to turn off the power and unplug the power cable before carrying out any work that requires direct contact with the interior of the product. If the work is to be performed in the power-on status, the instruction manual herein always states to that effect
- **Be sure to ground the earth terminal (not required in the case where a power cable with earth is used):**
This product is equipped with the earth terminal. When installing the product, connect the earth terminal to the "accurately grounded indoor earth terminal" by using an earth wire. Unless the product is grounded appropriately, the user can be subject to an electric shock. After performing repair, etc. for the control equipment, ensure that the earth wire is firmly connected to the control equipment
- **Ensure that the power supply used is equipped with an earth leakage breaker:**
Using a power supply which is not equipped with the earth leakage breaker can cause a fire when earth leakage occurs
- **Be sure to use fuses which meet the specified rating (only for the machines which use fuses):**
Using fuses that exceed the specified rating can cause a fire and an electric shock

- **Specification changes (removal of equipment, conversions and additions) not designated by SEGA are not allowed:**
The parts of the product include warning labels for safety, covers for personal protection, etc. It is very hazardous to operate the product by removing parts and/or modifying the circuits. Should doors, lids and protective parts be damaged or lost, refrain from operating the product, and contact where the product was purchased from or the office herein stated.
SEGA shall not be held responsible for any accidents or compensation for damage to a third party resulting from the specifications not designated by SEGA
 - **Ensure that the product meets the requirements of appropriate electrical specifications:**
Before installing the product, check for electrical specifications. Ensure that the product is compatible with the power supply voltage and frequency requirements of the location. Using any electrical specifications different from the designated specifications can cause a fire and an electric shock
 - **Install and operate the product in places where appropriate lighting is available, allowing warning labels to be clearly read:**
To ensure safety for the customers, labels and printed instructions describing potentially hazardous situations are applied to places where accidents can be caused. Ensure that where the product is operated has sufficient lighting allowing the warnings to be read. If any label is peeled off, apply it again immediately. Please place an order with where the product was purchased from or the office herein stated
 - **When handling the monitor, take considerable care (applies only to products with monitors):**
Some of the monitor parts are subject to high tension voltage. Even after turning off the power, some portions are still subject to high tension voltage. Monitor repair and replacement should be performed only by those technical personnel who have knowledge of electricity and technical expertise
 - **Be sure to adjust the monitor properly (applies only to products with monitors):**
Do not operate the product leaving on-screen flickering or blurring as it is. Using the product with the monitor not properly adjusted may cause dizziness or a headache to an operator, a player, or customer
 - **When transporting or reselling this product, be sure to attach this manual to the product**
- * *In the case where commercially available monitors and printers are used in this product, only the contents relating to this product are explained herein. Some commercially available equipment has functions and reactions not stated in this Manual. Read this Manual together with the specific instruction Manual of such equipment*
- * *Descriptions herein contained may be subject to improvement changes without notice*
- * *The contents described herein are fully prepared with due care. However, should any question arise or errors be found, please contact SEGA*

INSPECTIONS IMMEDIATELY AFTER TRANSPORTING THE PRODUCT TO THE LOCATION

Normally, at the time of shipment, SEGA products are in a status allowing for usage immediately after transporting to the location. Nevertheless, an irregular situation may occur during transportation. Before turning on the power, check the following points to ensure that the product has been transported in a satisfactory status:

- Are there any dented portions or defects (cuts, etc.) on the external surfaces of the cabinet?
- Are castors and adjusters damaged?
- Do the power supply voltage and frequency requirements meet with those of the location?
- Are all wiring connectors correctly and securely connected? Unless connected in the correct way, connector connections can not be made accurately. Do not insert connectors forcibly.
- Do power cables have cuts or dents?
- Are all accessories available?
- Can all doors and lids be opened with the accessory keys? Can doors and lids be firmly closed?

INTRODUCTION

This Manual is intended to provide detailed descriptions together with all necessary information covering the general operation of electronic assemblies, electromechanical, servicing control, spare parts, etc. for the product:

"Capto Crane + Capto Crane Midi + Capto Candy"

This Manual is intended for the owners and personnel managers in charge of operation of this product. Operate the product after carefully reading and sufficiently understanding the instructions.

In the unlikely event that the product does not function correctly, **DO NOT** allow anyone other than a technician to touch the internal system. Turn off the power to the machine, making sure to unplug the electrical cord from the outlet, and contact the office listed below or the point-of-purchase for this product.

Use of this product is unlikely to cause physical injuries or damage to property. However, points that require special attention are indicated by bold text, the words "**STOP**", "**IMPORTANT**", "**WARNING**", or "**CAUTION**" and the symbols below.

IMPORTANT!

Indicates important information that, if ignored, may result in the mishandling of the product and cause faulty operation or damage to the product

WARNING **CAUTION**

Indicates a warning or caution that, if ignored, may result in the mishandling of the product and cause faulty operation or damage to the product

Sega Amusements International Limited



42 Barwell Business Park, Leatherhead Road
Chessington
Surrey, KT9 2NY
United Kingdom

European Sales:	+44 (0)208 391 8090	Email:	sales@segaarcade.com
USA Sales:	+00 (1) 224 265 4287	Email:	sales@segaarcade.com
STS (Spares):	+44 (0) 208 391 8060 (Option 1)	Email:	stssales@segaarcade.com
Tech Support:	+44 (0)208 391 8060 (Option 2)	Email:	technical@segaarcade.com
Prize & Merchandise:	+44 (0)208 391 8060 (Option 1)	Email:	segaprize@segaarcade.com

Web: <https://segaarcade.com/>

SPECIFICATIONS***Capto Crane Cabinet***

Machine Dimensions:	0.81m (31.9in) [Width] x 0.83m (32.7in) [Depth]
Machine Height:	2.09m (82.3in) (Installed)
Machine Weight:	130kg Approx (Installed) (286lbs)
Power, maximum current:	-220w-

SPECIFICATIONS***Capto Crane Midi Cabinet***

Machine Dimensions:	1.00m (39.4in) [Width] x 0.87m (34.3in) [Depth]
Machine Height:	2.09m (82.3in) (Installed)
Machine Weight:	150kg Approx (Installed) (330lbs)
Power, maximum current:	-230w-

SPECIFICATIONS***Capto Candy Cabinet***

Machine Dimensions:	0.81m (31.9in) [Width] x 0.83m (32.7in) [Depth]
Machine Height:	2.09m (82.3in) (Installed)
Machine Weight:	130kg Approx (Installed) (286lbs)
Power, maximum current:	-220w-



IMPORTANT!

Procedures not described in this Manual or marked as 'to be carried out by Site Maintenance Personnel or other qualified professionals' should not be carried out by personnel without the necessary skill or technological experience. Work carried out by unqualified persons may cause serious accidents, including electrocution

Parts replacement, maintenance inspections, and troubleshooting should be carried out by site maintenance personnel or other qualified professionals. This Manual includes directions for potentially dangerous procedures which should only be carried out by professionals with the appropriate specialised knowledge.

The site maintenance personnel or other qualified professionals mentioned in this Manual are defined as follows:

Site Maintenance Personnel:

Individuals with experience in maintaining amusement equipment, vending machines, etc., working under the supervision of the owner/operator of this product to maintain machines within amusement facilities or similar premises by carrying out everyday procedures such as assembly, maintenance inspections, and replacement of units/expendable parts.

Activities to be carried out by Site Maintenance Personnel:

Amusement equipment/vending machine assembly, maintenance inspection and replacement of units/expendable parts.

Other qualified professionals:

Persons employed by amusement equipment manufacturers, or involved in design, production, testing or maintenance of amusement equipment. The individual should have either graduated from technical school or hold similar qualifications in electrical/electronics/mechanical engineering.

Activities to be carried out by other qualified professionals:

Amusement equipment/vending machine assembly, repair/adjustment of electrical/electronic/mechanical parts.

Waste of Electrical and Electronic Equipment (WEEE) Statement

The WEEE (Waste of Electrical and Electronic Equipment) directive places an obligation on all EU based manufacturers and importers of Electrical and Electronic Equipment (EEE) to ensure waste equipment is disposed of in accordance with the directive at the end of their useful life.

The symbol shown below will be placed on all products manufactured from 13th August 2005, which indicates this product must NOT be disposed of with other normal waste.

Upon purchasing any EEE from SEGA Amusements International Ltd., the user accepts responsibility to dispose of their waste equipment by arranging to return it to a designated UK collection point (AATF) or an Approved Exporter (AE) for the correct recycling of waste electrical and electronic equipment.

For more information on Approved Authorised Treatment Facilities (AATF) within the UK please consult the government website: www.gov.uk/weee

For users outside of the UK, EEE should be disposed of in accordance with the local policy on the recycling of Waste Electrical and Electronic Equipment.

Battery Recycling Statement

The EC Directive on Batteries and Accumulators (2006/66/EC) aims to minimise the impact of batteries on the environment and encourage the recovery of the materials they contain. To achieve increased collection and recycling of waste batteries, the Directive places 'producer responsibility' obligations on manufacturers and importers of portable, industrial and automotive batteries.

The symbol shown below will be on all equipment fitted with batteries from 26th September 2008 and indicates they must NOT be disposed of with other normal waste. Instead, it is the user's responsibility to dispose of used batteries by arranging to return them to a designated collection point for the correct recycling.

For more information about where you can send your waste batteries for recycling contact your local authority office.



READ BEFORE OPERATING

OPERATOR NOTICE OF LEGAL REQUIREMENTS

It is the responsibility of the operator to operate this game in line with local jurisdictions and the countries laws. All prizes used **MUST** conform to local operating laws for this type of product.

This prize offering game device has many settings and operator options to accommodate various marketing concepts, a wide range of prizes, and use in most International Territories.

In the USA and other countries individual state statutes and local jurisdiction codes can impact payment required amusement themed and designed games offering prizes, including the type and value of the prizes. Further the degree of skill requirements vary. **Not all settings and options are suitable for every jurisdiction.**

It is solely your responsibility as the operator of the game to fully comply with laws, regulations and prize value and type limitations in the jurisdiction where you place and offer this game to the public. (Contact your legal adviser):

- **SKILL CONSIDERATIONS:** Generally the greater the degree of control that players have as to the movements of the retrieval tool the more likely that the element of "skill" will be present. This infers that the prizes offered are retrievable at any point in time when the skill requirement is achieved in accord with posted rules of play
- Test at each service that all player controls and the machinery work and track smoothly and time and rules display are fully visible and working
- If the machine is ever moved, violently bumped, or tilted then it is recommended that the machine is re-calibrated
- Good maintenance and cleaning of the game and cabinetry is good business and enhances your sales. A poorly maintained machine may not continue to work in the way in which it was designed
- Tips and notices to players should be posted behind a protective cover or glass and easily viewed from the player's position
- Do not alter the machine's CPU board, circuitry, components, or change the EPROM software without the manufacturer's authorization. Doing so can result in criminal or civil liabilities, and void your factory warranty
- Do not alter or modify this machine in any shape or form other than that described in the Manual. Doing so can result in criminal or civil liabilities, and void your factory warranty
- Neither manufacturer nor the distributor is responsible for any losses of prizes from this machine. It is the responsibility of the operator to set up that machine in accordance with the Manual and maintain a level of security around the machine adequate for the level of prizes contained therein
- If you have questions or need technical assistance, call the manufacturer or your authorized distributor for guidance

TABLE OF CONTENTS

INTRODUCTION	iii
HANDLING PRECAUTIONS	1
PRECAUTIONS REGARDING INSTALLATION	5
- Limitations of use	5
- Operation Area	6
PRECAUTIONS REGARDING OPERATION	8
- Before Operation	8
- Paying Attention to Customers	10
ASSEMBLY AND INSTALLATION	12
- Installation Process - Unpacking the Cab	13
- Installation Process - Main Cabinet	14
- Installation Process - Wiring Connections	16
- Fixation to Site	17
GAME DESCRIPTION	20
TEST AND SERVICE DATA	22
PARTS LIST (CC + Candy)	33
PARTS LIST (Capto Crane Midi)	46
SCHEMATIC DIAGRAM	58

HANDLING PRECAUTIONS

When installing or inspecting the machine, be mindful of the following points and pay attention to ensure that the player can enjoy the game safely.

Noncompliance with the following points or inappropriate handling running counter to the cautionary matters herein stated can cause personal injury or damage to the machine.

WARNING

- **Before performing work, be sure to turn the power off. Performing the work without turning the power off can cause an electric shock or short circuit. In cases where work should be performed in the status of power on, this Manual always states to that effect**
- **To avoid an electric shock or short circuit, do not plug in or unplug quickly**
- **To avoid an electric shock, do not plug in or unplug with a wet hand**
- **Do not expose power cords or earth wires on the surface, (floor, passage, etc). If exposed, the power cords and earth wires are susceptible to damage. Damaged cords and wires can cause an electric shock or short circuit**
- **To avoid causing a fire or an electric shock, do not put things on or damage the power cords**
- **During or after installing the product, do not unnecessarily pull the power cord. If damaged, the power cord can cause a fire or an electric shock**
- **In the case that the power cord is damaged, ask for a replacement through where the product was purchased from or the office herein stated. Using the cord as is damaged can cause fire, an electric shock or leakage**
- **Be sure to perform grounding appropriately. Inappropriate grounding can cause an electric shock**
- **Be sure to use fuses meeting the specified rating. Using fuses exceeding the specified rating can cause a fire or an electric shock**
- **Be sure that connections such as IC Board are made properly. Insufficient insertion can cause an electric shock**
- **Specification changes, removal of equipment, conversion and/or addition, not designated by SEGA are not permitted**
- **Failure to observe this may cause a fire or an electric shock. Noncompliance with this instruction can have a bad influence upon the physical conditions of players or onlookers, or result in injury during play**
- **SEGA shall not be held responsible for damage or compensation for damage to a third party caused by specification changes not designated by SEGA**
- **Do not perform any work or change parts not listed in this Manual. Doing so may lead to an accident**
- **If you need to perform any work not listed in this Manual, request work from the office indicated in this manual or the point of purchase, or inquires for details. Be sure to perform periodic maintenance inspections herein stated**

 **WARNING**

- Do not touch undesignated places. Touching places not designated can cause electric shock or short circuit
- Whenever any fasteners (e.g. screws, nuts) have been lost, be sure to use replacement fasteners with proper dimensions as specified in this Manual. If fasteners of any other dimensions are used, it could cause damage and/or separation of parts that result in secondary accidents
- Specification changes, removal of equipment, conversion and/or addition, not designated by SEGA are not permitted
- Failure to observe this may cause a fire or an electric shock. Noncompliance with this instruction can have a bad influence upon the physical conditions of players and onlookers, or result in injury during play
- SEGA shall not be held responsible for damage or compensation for damage to a third party caused by specification changes not designated by SEGA
- Performing work or parts replacements not described in this Manual could result in accidents. If you need to perform any work not listed in this Manual, request work from the office indicated in this Manual or the point-of-purchase, or inquires for details
- Be sure to perform periodic maintenance inspections herein stated

 **IMPORTANT!**

- For the IC board circuit inspections, only the use of a logic tester is recommended. Using a Multi-Tester or General Purpose Tester may result in damage to IC Circuits
- Static electricity from your body may damage some electronic devices on the IC board. Before handling the IC board, touch a grounded metallic surface so that the static electricity can be discharged
- Some parts are not designed or manufactured specifically for this game machine. The manufacturers may discontinue or change the specifications of such general-purpose parts. If this is the case, SEGA cannot repair or replace a failed game machine whether or not a warranty period has expired

CONCERNING THE STICKER DISPLAY

This SEGA product has stickers attached describing the product manufacture No. (Serial No.) and Electrical Specifications. It also has a Sticker describing where to contact for repair and for purchasing parts.

When inquiring about or asking for repairs, **mention the Serial No. and Name of Machine indicated on the Sticker.**

The Serial Number indicates the product register. Identical machines could have different parts depending on the date of production. Also, improvements and modifications might have been made after the publication of this Manual.

In order to ensure you order the correct parts, mention the Serial No. when contacting the applicable places.

CONCERNING WARNING DISPLAYS

This SEGA product has warning displays on stickers, labels and/or printed instructions adhered/attached to or incorporated in the places where a potentially hazardous situation could arise. The warning displays are intended for accident prevention for customers and for avoiding hazardous situations relating to maintenance and servicing work.

Some portions of the Cabinet contain high voltage and may cause accidents if touched. When performing maintenance, be very careful of the warning displays. It is especially important that any complex repair and replacement work not mentioned herein should be performed by those technical personnel who have knowledge of electricity and has technical expertise.

In order to prevent accidents, caution any customer ignoring the warnings to cease and desist immediately.

Safety label layout

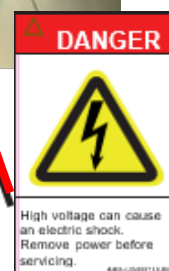

PRECAUTIONS REGARDING INSTALLATION

WARNING

- This product is an indoor game machine. Do not install it outside. Even indoors, avoid installing in places mentioned below so as not to cause fire, electric shock, injury and/or malfunction:
- Places subject to rain/water leakage or places subject to high humidity, in the proximity of an indoor swimming pool and/or shower, etc
- Places subject to direct sunlight or places subject to high temperatures, in the proximity of heating units, etc
- Places filled with inflammable gas or vicinity of highly inflammable/volatile chemicals or hazardous matter
- In dusty places or locations prone to heavy dust accumulation
- On sloped or uneven surfaces
- Places subject to any type of violent impact
- Vicinity of anti-disaster facilities such as fire exits and fire extinguishers
- Areas where the temperature exceeds the applicable temperature (ambient temperature) range of 5 to 30 degrees centigrade

LIMITATIONS OF USAGE

WARNING

- Be sure to check the Electrical Specifications. Ensure that this product is compatible with the location's power supply, voltage, and frequency requirements. A plate describing Electrical Specifications is attached to the product. Noncompliance with the Electrical Specifications can cause a fire and electric shock
- This product requires a Breaker and Earth Mechanism as part of the location facilities. Using the product without these can cause a fire and electric shock
- Ensure that the indoor wiring for the power supply is rated at 15 A or higher (AC single phase 100 V ~ 120 V area), and 7 A or higher (AC 220 V ~ 240 V area). Noncompliance with the Electrical Specifications can cause a fire and electric shock
- Be sure to use an independent power supply equipped with an Earth Leakage Breaker. Using a power supply without an Earth Leakage Breaker can cause an outbreak of fire if a power surge occurs
- Putting many loads on one electrical outlet can cause generation of heat and a fire resulting from overload
- When using an extension cord, ensure that the cord is rated at 15 A or higher (AC 100 V ~ 120 V area) and 7 A or higher (AC 220 V ~ 240 V area). Using a cord rated lower than the specified rating can cause a fire and electric shock



IMPORTANT!

- Securing a safe area for operation as described in this Manual will ensure safe operation for players and observers
- SEGA shall not be held responsible for damage or compensation for damage to a third party, resulting from the failure to observe this instruction

OPERATION AREA

WARNING

- For safe operation, use and operate this product in an area measuring at least **2.00m (78.8in)** in width and **1.9m (74.8in)** in depth when the Cabinet is installed. SEGA shall not be held responsible for damage or compensation for damage to a third party, resulting from the failure to observe this instruction
- The ceiling where this product is installed must be at least **2.1m (82.7in)** high. If the ceiling is too low, the heat emitted from the product may cause it to catch on fire
- Be sure to provide the sufficient space specified in this Manual. Do not allow objects to block the ventilation ports. This can cause generation of heat and a fire
- Put the Cabinets close together so that people cannot get through or provide enough space between them that people can go both ways without difficulty. If the Cabinets are installed carelessly, people may bump into each other or the Cabinets when passing between them or fall down. To prevent people from walking between them, place them 0.15 m (5.9 in) apart
- If the machine does not fit through the entryway to the installation location, do not disassemble it without first consulting the instructions. Specific tools and adjustment procedures are required to assemble and disassemble the mechanical parts
- Attempting to assemble or disassemble the machine without consulting the instructions may result in accidents during assembly/disassembly, electric shock, short circuits, and/or personal injury during operation. If the machine still does not fit through the entryway after following the procedures in this Manual, contact your retailer or the office listed in this Manual
- If the machine is still too large to fit through the entryway after following the procedures listed in this Manual, do not tip the machine on its side. Attempting to transport the machine while it is tipped on its side may cause accidents. It may also damage or warp parts of the machine, resulting in accidents during operation

⚠ WARNING

- To install this product, the entrance must be at least **0.88m (34.7in)** in width and **2.1m (82.7in)** in height
- If the entrance is too narrow, do not tilt the product carelessly. If all the product weight is put on the castors at one side only, there could be damage or deformation, causing serious accidents such as workers getting caught underneath

(not to scale)

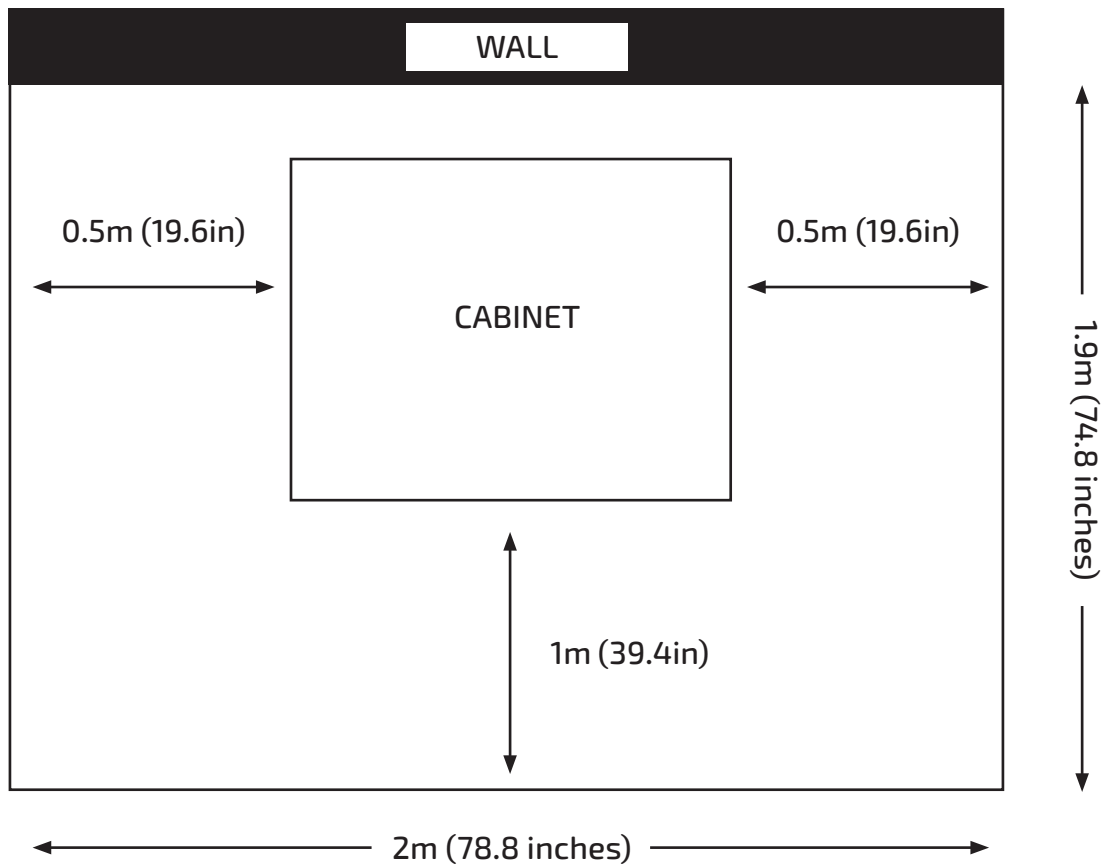

PRECAUTIONS REGARDING OPERATION

To avoid injury and trouble, be sure to pay attention to the behaviour of visitors and players.

BEFORE OPERATION

WARNING

- In order to avoid accidents, check the following before starting the operation:
- To ensure maximum safety for the players and the customers, ensure that where the product is operated has sufficient lighting to allow any warnings to be read. Operation under insufficient lighting can cause bodily contact with each other, hitting accident, and/or trouble between customers
- It is suggested to ensure a space allowing the players who feel sick while playing the game to take a rest
- Check if all of the adjusters are in contact with the surface. If they are not, the Cabinet can move and cause an accident
- Do not put any heavy item on this product. Placing any heavy item on the product can cause a falling down accident or parts damage
- Do not climb on the product. Climbing on the product can cause falling down accidents. To check the top portion of the product, use a step/stepladder
- To avoid electric shock, check to see if door and cover parts are damaged or omitted
- Do not place the following items on top of or near the product or hang them from the ceiling. Doing so could result in electric shock, short circuits and/or damage to the parts:
- Flower vases, flowerpots, cups, water tanks, cosmetics, and receptacles/containers/vessels containing chemicals and water

CAUTION

- To avoid injury, be sure to provide sufficient space by considering the potentially crowded situation at the installation location. Insufficient installation space can cause contact, collisions, and/or trouble between customers
- During daily cleaning, be sure to check the surface of the Control Unit and other parts that the player touches with his/her hands for damage, cracks, or loose screws. If a player uses the machine while it is damaged, cracked, or has a loose screw, the player may become injured
- Check carefully to make sure there are no gaps in the Cabinet joints and that they are not loose. If there are gaps or looseness, players may get their hands or fingers caught, resulting in an injury
- Make sure all the doors are locked securely and they do not rattle. If the doors are not locked properly or there are gaps or rattling, players could get their fingers or hands caught
- Inspect for the following items during a trial run. If there is any type of error, use the Test Mode, etc. to resolve the problem. If you continue use with an error, it can cause an accident or irreparable parts damage:
 - Is there any strangeness in the operability of the Control Unit?
- Prepare a place where players can rest if they feel sick

PAYING ATTENTION TO CUSTOMERS

To avoid injury and trouble, be sure to constantly give careful attention to the behaviour and manner of the visitors and players.

DURING OPERATION (PAYING ATTENTION TO CUSTOMERS)

WARNING

- For safety reasons, do not allow any of the following people to play the game:
 - Those who have high blood pressure or a heart problem
 - Those who have experienced muscle convulsion or loss of consciousness when playing video games, etc
 - Those who have neck or spinal cord problems
 - Those who are intoxicated or under the influence of drugs
 - Pregnant women
 - Those who are not in good health
 - Those who do not follow the attendant's instructions
 - Those who cannot grasp the Control Unit securely because of immobility in fingers, hands or arms
 - Persons who disregard the product's warning displays
- Even players who have never been adversely affected by light stimulus might experience dizziness or headache depending on their physical condition when playing the game
- Small children are especially likely to experience these symptoms. Caution guardians of small children to keep watch over them during play
- Instruct those who feel sick during play to have a medical examination
- To avoid injury from falls and electric shocks due to spilled drinks, instruct the player not to place heavy items or drinks on the product
- To avoid electric shocks and short circuits, do not allow customers to put hands, fingers or extraneous matter in the openings of the product or small openings in and around the doors
- To avoid falls and resulting injury, immediately stop the customer from leaning against or climbing on the product, etc
- To avoid electric shock and short circuit, do not allow customers to unplug the power plug without a justifiable reason
- Instruct the guardians of small children to keep watch over their children
- Children cannot sense danger. Allowing small children to get near a player who is playing the game could result in the children being bumped, struck or knocked down



IMPORTANT!

- Diligently clean the parts that players touch directly to ensure a pleasant game playing experience
- Inspect the coin insertion slots to make sure no foreign objects have been inserted and that they have not otherwise been tampered with as this will prevent play

CAUTION

- Immediately stop such violent acts as hitting and kicking the product. Such violent acts can cause parts damage or falling down, resulting in injury due to fragments and falling down
- Persons other than the player should not be allowed to touch the controls during play. They may brush against or collide with the controls or the player, possibly resulting in accidents
- Instruct those who feel sick during play to have a medical examination
- Immediately stop users from leaning or sitting on the Control Panel. Such acts can lead to injury or damage to parts or the shape of the Cabinet

WARNING

- Perform assembly work by following the procedure herein stated. Failure to comply with the instructions can cause electric shock
- Perform assembling as per this Manual. Since this is a complex machine, incorrect assembling can cause an electric shock, machine damage and/or improper functioning as per specified performance
- When assembling, more than one person is required. Depending on the assembly work, there are some cases in which working by one person alone can cause personal injury or parts damage
- Ensure that connectors are properly connected. Improper connections can cause electric shock
- Be careful not to damage the wires. Damaged wires may cause electric shock or short circuit or present a risk of fire
- This work should be carried out by site maintenance personnel or other qualified professionals. Work performed by non-technical personnel can cause a severe accident such as electric shock. Failing to comply with this instruction can cause a severe accident such as electric shock to the player during operation. If no one with proper technological expertise is available, request service from the office indicated in this document or the point of purchase so as to ensure safety
- Provide sufficient space so that assembling can be performed. Performing work in places with narrow space or low ceiling may cause an accident and assembly work to be difficult
- To perform work safely and avoid serious accident such as the Cabinet falling down, do not perform work in places where step-like grade differences, a ditch, or slope exist
- Do not leave power cords or Ground Wires exposed in areas of heavy foot traffic. Doing so may cause them to become damaged, possibly resulting in electric shock and/or short circuits. When laying wiring across the floor, always use safety covers to protect the wires. (Wiring diameter: power cable - approx. \varnothing 8)
- Have a flashlight or another supplementary lighting unit available while working. With indoor lighting alone, the Cabinet interior may be too dark. Working without proper lighting can lead to accidents. It also hinders proper work performance
- The Cabinet has ventilation ports. Be sure not to block them. If they are blocked, heat can build up, leading to fire. This can also accelerate wearing of parts and malfunctions
- Secure ample ventilation space around the Cabinet. If heat builds up, there could be accidents associated with heat or smoke generation
- This product does not use any connectors other than those connected to and used by the Game Board when it leaves the factory. Do not needlessly connect wires to unused connectors. This could lead to overheating, generation of smoke and burn related injuries

CAUTION

- Handle molded parts with care. Excessive weight or pressure may cause them to break and the broken pieces may cause injury
- To perform the operations at height safely and accurately you must use a safe, steady footstool or stepladder. Working without this may lead to a fall and possible injury
- When attaching or removing doors or lids, be careful that your hand or finger does not get caught in anything

INSTALLATION PROCESS - UNPACKING THE CABINET

- 1** Cut the banding straps from over the Cabinet
- 2** Using a forklift, carefully lift the game off of the pallet
- 3** Open the Lower Rear Door, remove the Control Panel, and unwrap
- 4** Open the Back Door, remove the Cash Box Assembly + Control Panel, and unwrap

INSTALLATION PROCESS - MAIN CABINET

STOP IMPORTANT!

- Be careful not to damage parts surfaces. In some cases, if such surfaces are damaged, the part must be replaced; it cannot be reinforced or repaired
- Ensure to carry out the installation with a minimum of **2 people**

1 Secure the Cash Box Assembly using 4 x Fixings (2 Side - 2 Back)

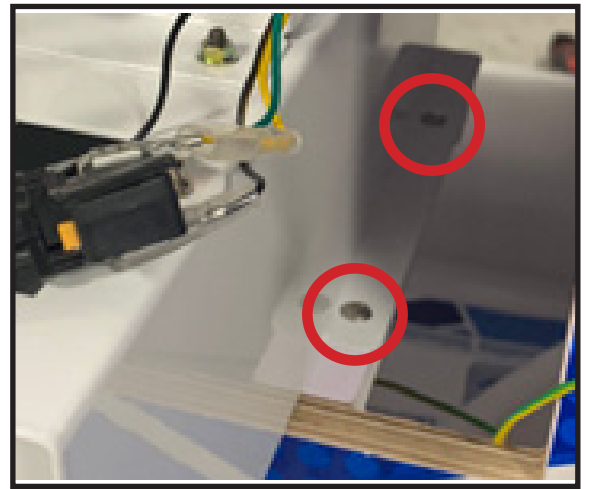

2 Install the control panel by hooking the control panel screws through the top holes in the Cabinet eyelets

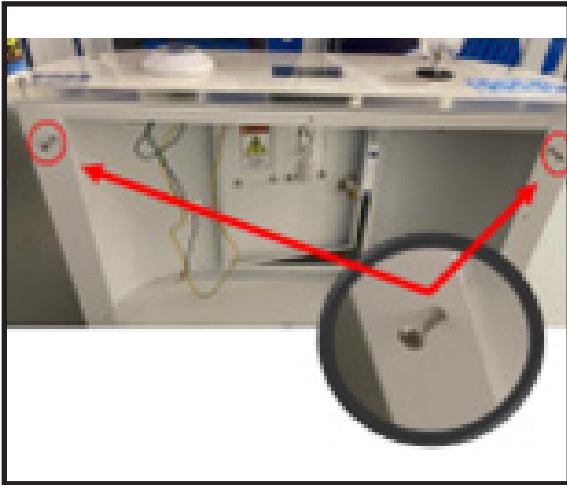

3 From inside the back door, fit and secure the remaining 3 x screws and tighten the top screw

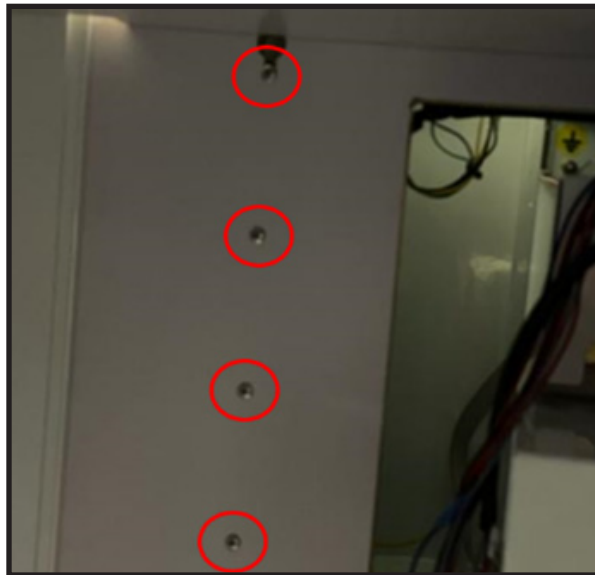

4 Open the glass door, remove 2 x screws securing the Diverter Plate and remove the Plate



5 Add 3 x screws to the rear of the Control Panel and secure



INSTALLATION PROCESS - WIRING CONNECTIONS

1 Connect the 4 x Control Panel peripheral harnesses (LCD - Joystick - Button - Speaker)

Note: DO NOT connect the spare 12v Cable

LCD Harness

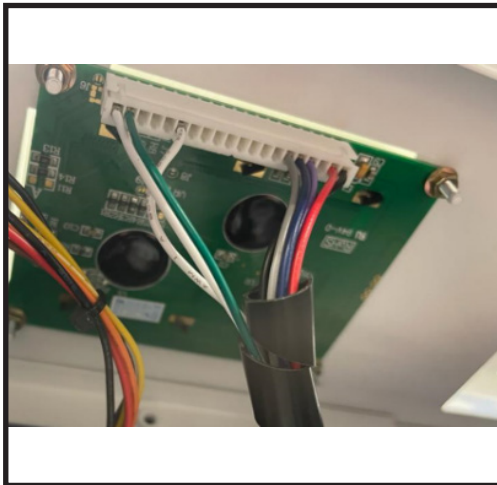

Joystick Harness

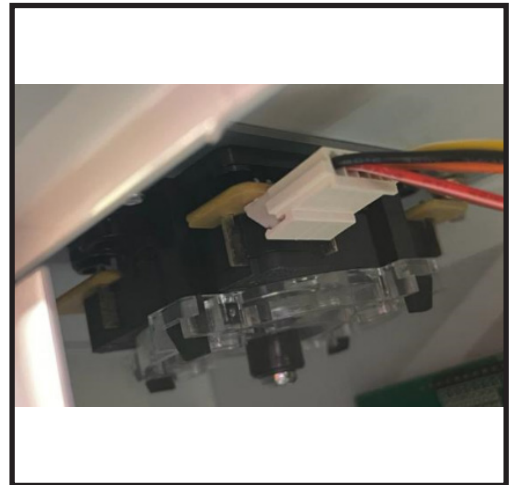

Button Harness

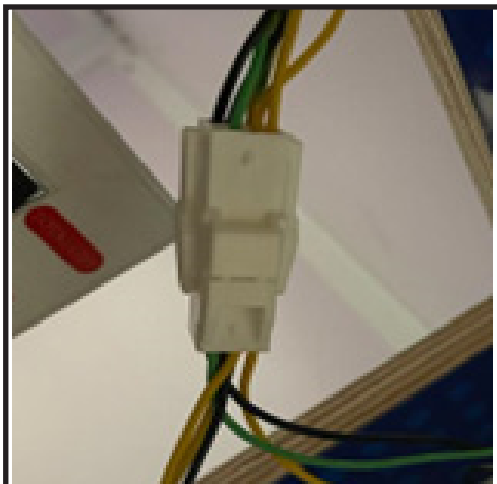

Speaker Harness



FIXATION TO INSTALLATION SITE

WARNING

Make sure that all the adjusters contact the floor. Otherwise the Cabinet could move, causing an accident

The product comes with castors and adjusters at multiple locations.

When the installation site has been determined, have the adjusters come in direct contact with the floor. Establish a gap of at least 5 mm between the floor and the castors and adjust the unit so that it will remain level.

- 1** Move the product to the installation site. If the product is to be installed near a wall, secure enough passageway space for players to access the seat. You must also secure a 15cm space between the back wall and the back of the cabinet for ventilation
- 2** Bring the adjusters into direct contact with the floor. Use a wrench to align the height of the adjusters until the Cabinet is perfectly level
- 3** After setting, turn adjuster nuts upwards to tighten them and secure adjuster heights

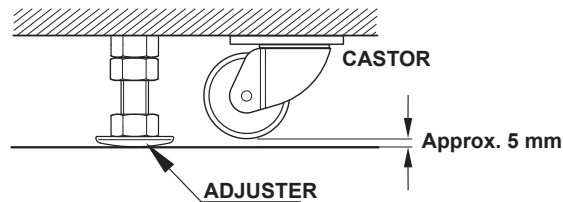
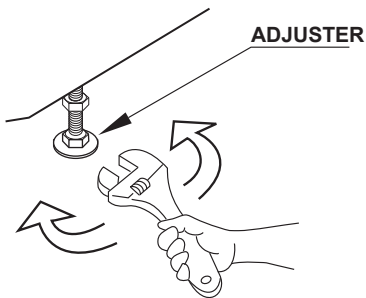

CONNECTION OF POWER AND GROUND CABLES

(Only applies where an integral earth is not present in the mains/power lead.)

WARNING

- Use the power supply equipped with an earth leakage breaker. Use of power supply without such a breaker could result in fire if there is a current leakage
- Have available a securely grounded indoor ground terminal. Without proper grounding, customers could be electrocuted and product operations might not always be stable
- Do not expose the power cord or ground wire. If these are exposed, customers could stumble over them, for instance, and easily damage them. Additionally, if these lines are damaged, there could be a risk of electrical shock or short circuit. Set these lines at locations where they will not interfere with customer traffic, or attach covers to them
- After laying out the power cord on the floor, be sure to always protect it. If the power cord is left exposed, it can easily be damaged, resulting in electrical shock
- When using the product's AC unit ground terminal, use ground wire with a circular terminal as shown in the illustration, and establish ground securely. Avoid indiscriminate grounding operations such as use of wire with only its sheath peeled off

IMPORTANT!

If grounding has been established with the ground wire inside the power cord, do not perform grounding with the AC unit ground terminal. Conversely, if the AC unit ground terminal has been used for grounding, do not establish ground with the ground wire in the power cord. Otherwise there could be faulty or erroneous operations

-
- 1** Confirm that the main switch is at OFF

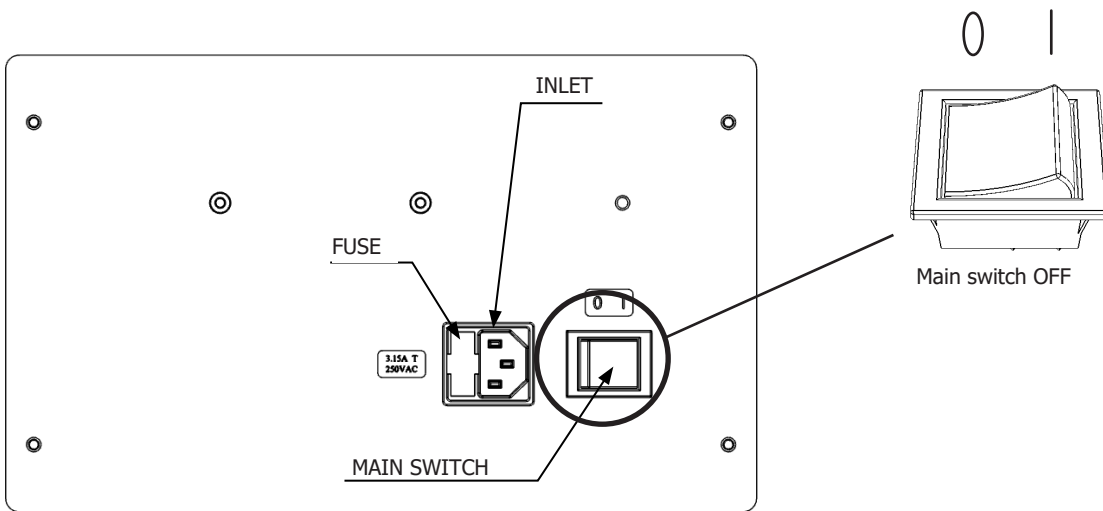

-
- 2** Fully insert the power cord connector on the side opposite the power plug into the AC unit inlet

-
- 3** Fully insert the power cord plug into the outlet

-
- 4** The power cord is laid out indoors. Protect the power cord by attaching wire cover to it. If ground will be established with a ground wire made available separately, lay out the ground wire indoors and have it protected

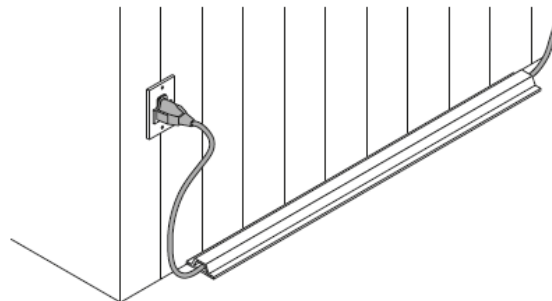

PARTS LIST (CAPTO CRANE + CAPTO CANDY)

No.	Name	Part Code	Quantity
1	Cabinet	Diagram:1-Cabinet	1
2	Glass Door Assembly	Diagram:2-Glass Door Assembly	1
3	Cash Machine Frame Assembly	Diagram:3-Cash Machine Frame Assembly	1
4	Console Sheet Metal Assembly	Diagram:4-Console Sheet Metal Assembly	1
5	Coin Box	07.023.154	1
6	Control Panel	Diagram:6-Service Panel	1
7	Crane Assembly	01.012.003	1
8	Chassis Power Supply	01.005.012	1
9	Light Strip Power Supply	01.005.013	1
10	Gift Baffle - 2	06.028.028	1
11	Gift Baffle - 1	06.028.027	1
12	Sensor Board	01.019.058	1
13	Carpet	01.015.039	1
14	Power Box Cover NO:14	06.028.034	1
15	Rear Small Door	07.023.190	1
16	Anti-Shake Device	01.016.015	1
17	Power Box Assembly	Diagram:17-Power Supply Box Assembly	1
18	Rod for Gift Machine (70-120)	01.015.009	2

Overview

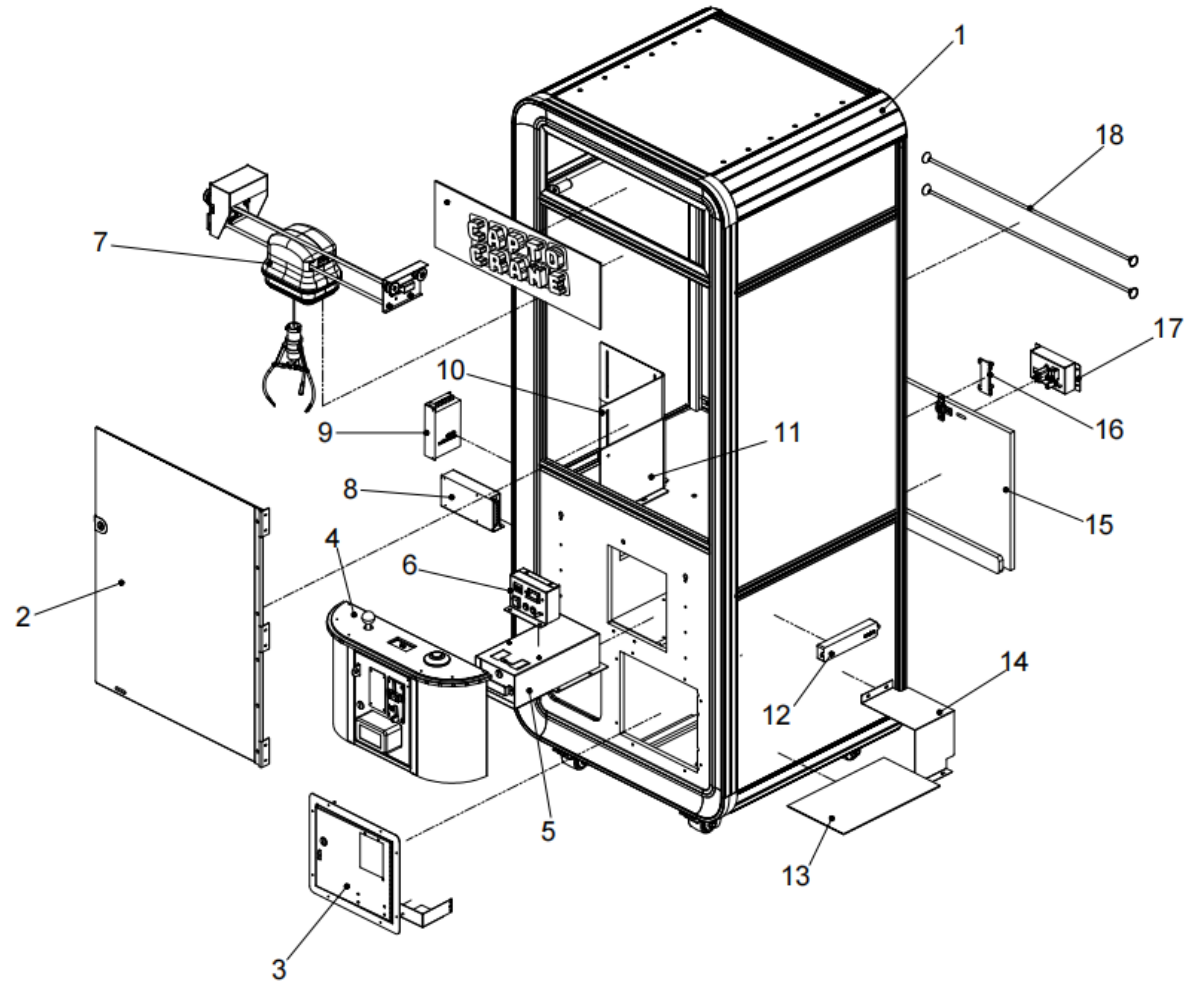

No.	Name	Part Code	Quantity
1	Card Reader Cover Plate	07.023.229	1
2	Card Reader Mounting Plate	07.023.179	1
3	Coin Acceptor Panel	\	1
4	Bill Validator Cover Plate	07.023.175	1
5	Console Door Panel - 2	07.023.180	1
6	Console Sheet Metal Weldment	07.023.230	1
7	Speaker	01.016.008	1
8	Console Panel	07.023.144	1
9	NO:6	06.028.026	1
10	\	\	1
11	Joystick - B	01.008.030	1
12	LCD Panel	01.002.009	1
13	White Rainbow Button	01.008.020	1
14	Console Door Panel - 1	07.023.197	1

Diagram4-Console Sheet Metal Assembly

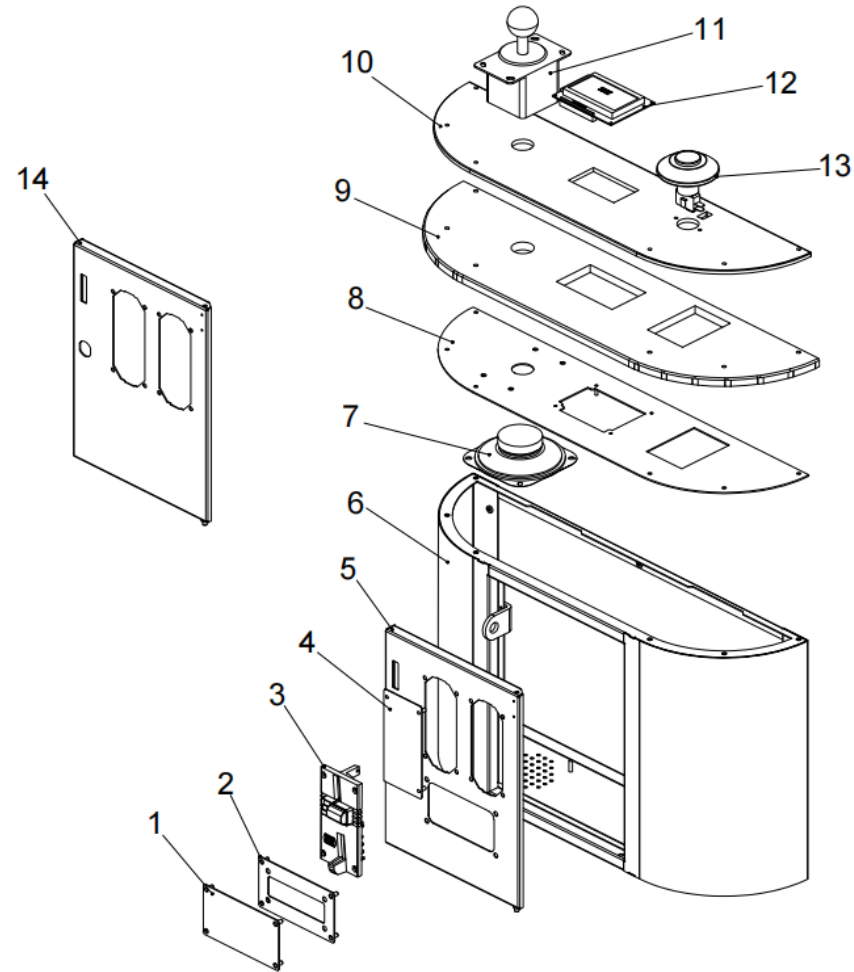

No.	Name	Part Code	Quantity
1	Glass Door Panel	07.023.181	1
2	Glass Door Hinge 1	07.023.120	1
3	Mirror Finish Stainless Steel Glass Door Hinge Press Strip	07.023.153	1
4	Hinge Rod 1	07.023.156	1
5	Glass Door Hinge 2	07.023.119	3
6	Mirror Finish Stainless Steel Glass Door Lock Plate	07.023.151	1

Diagram2-Glass Door Assembly

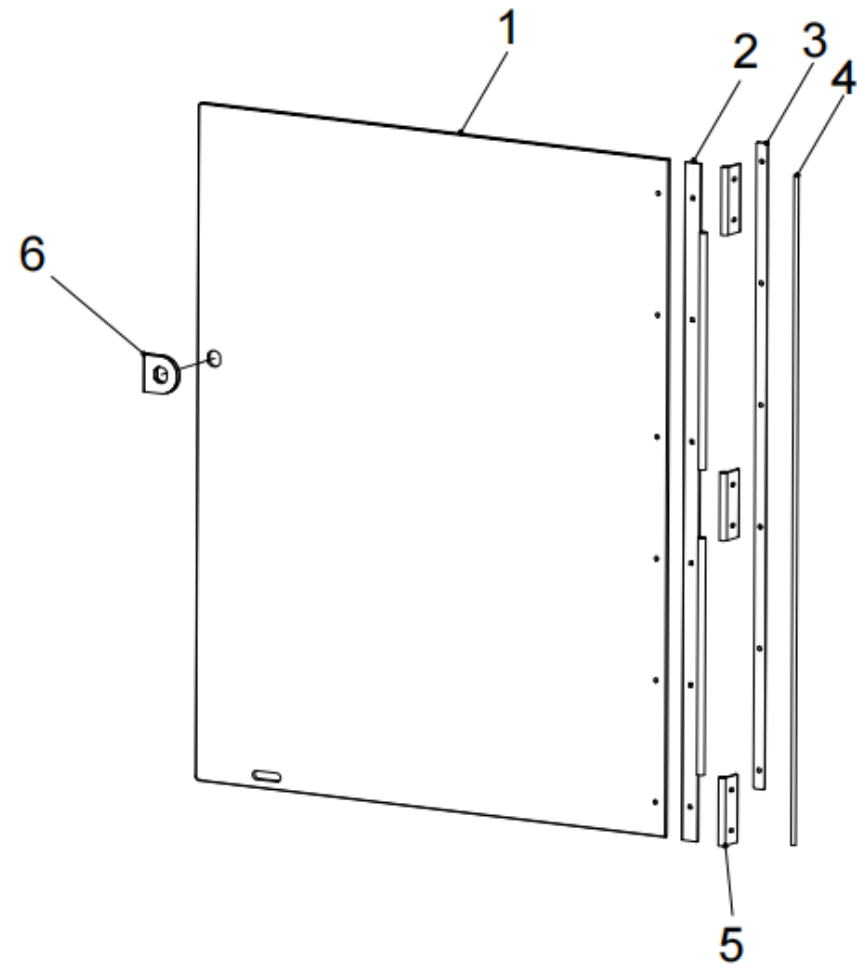

No.	Name	Part Code	Quantity
1	Door Panel Sheet Metal Weldment	07.023.171	1
2	Bill Validator Cover Plate - 2	07.023.176	1
3	Door Panel Frame	07.023.172	1
4	Fixing Plate	07.023.178	1
5	Hinge Assembly	07.023.177	1

Diagram3-Cash Machine Frame Assembly

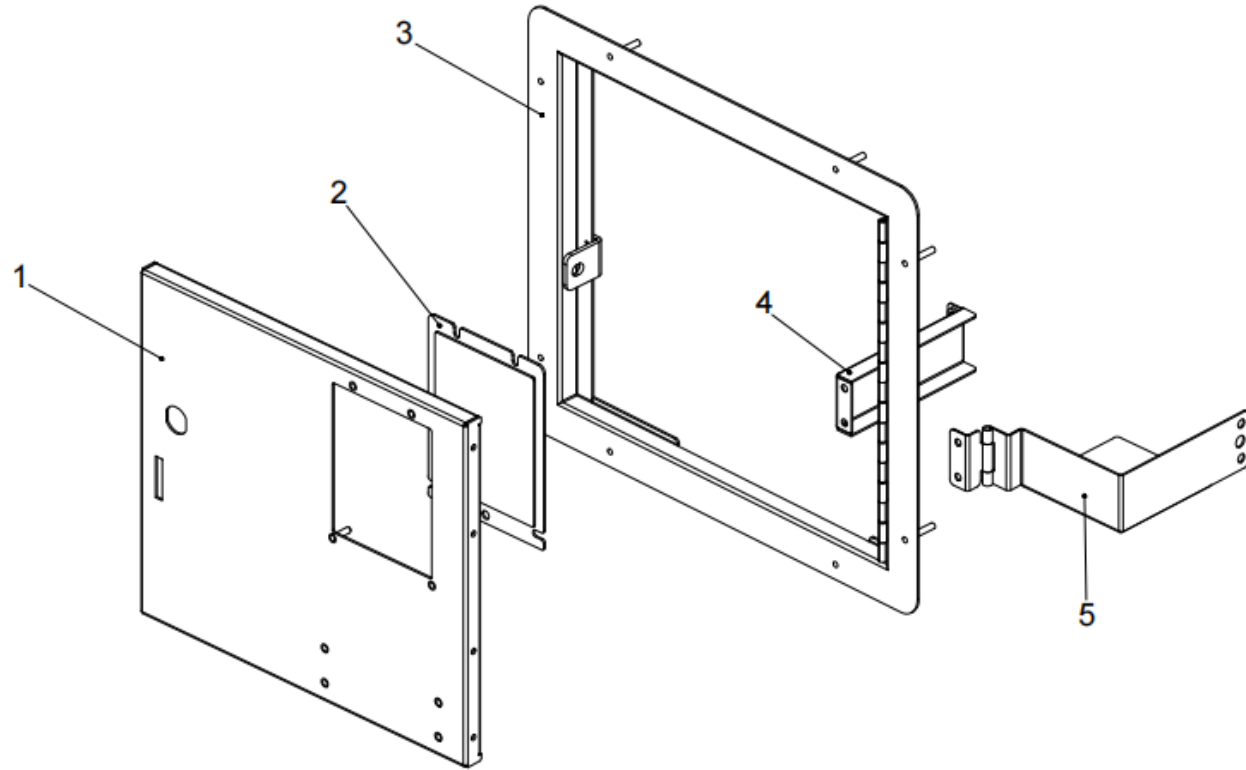

No.	Name	Part Code	Quantity
1	Universal Fuse Holder	01.016.004	1
2	Universal Power Switch	01.016.003	
3	Filter	01.016.102	1
4	Power Switch Box	07.023.140	1

Diagram:17-Power Supply Box Assembly

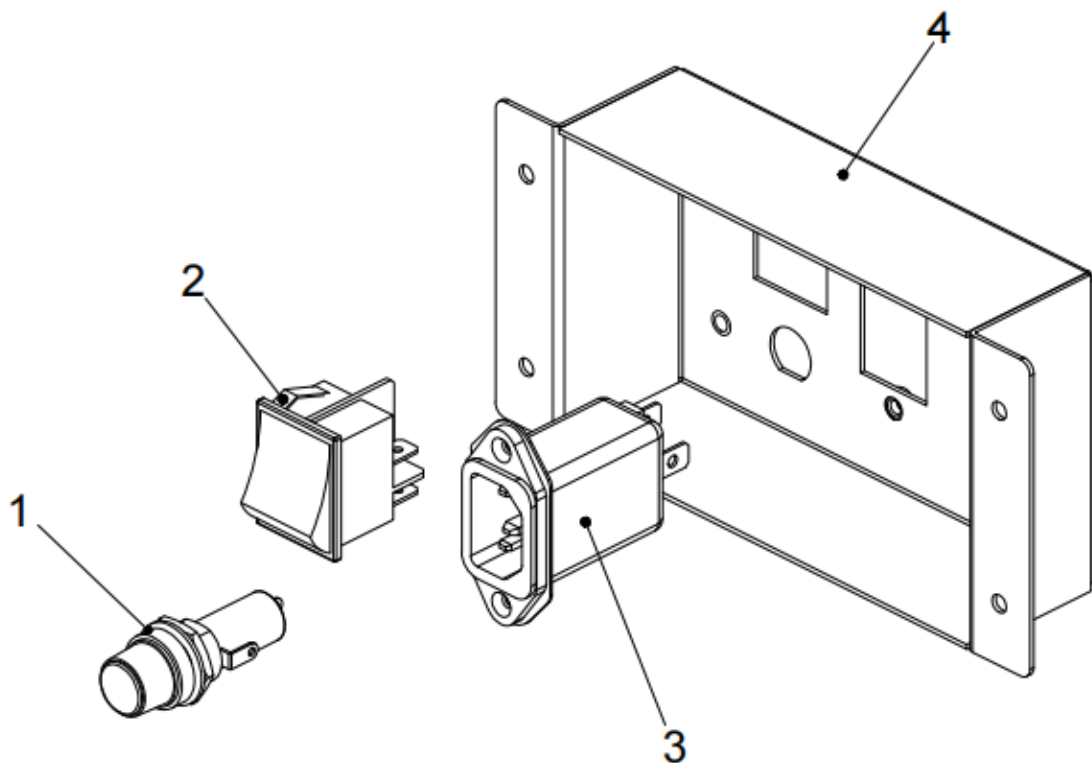

No.	Name	Part Code	Quantity
1	Universal Power Switch	01.016.003	1
2	Universal Setting Button - Red	01.008.017	1
3	Universal Setting Button - Green	01.008.015	1
4	Service Panel	07.023.148	1
5	Mechanical Tachometer	01.016.032	1
6	Knob Switch	01.016.101	1
7	Universal Electronic Tachometer	01.016.051	1
8	Digital meter Bracket	07.023.147	1
9	Service Panel Cover Plate	07.023.010	1

Diagram6-Service Panel

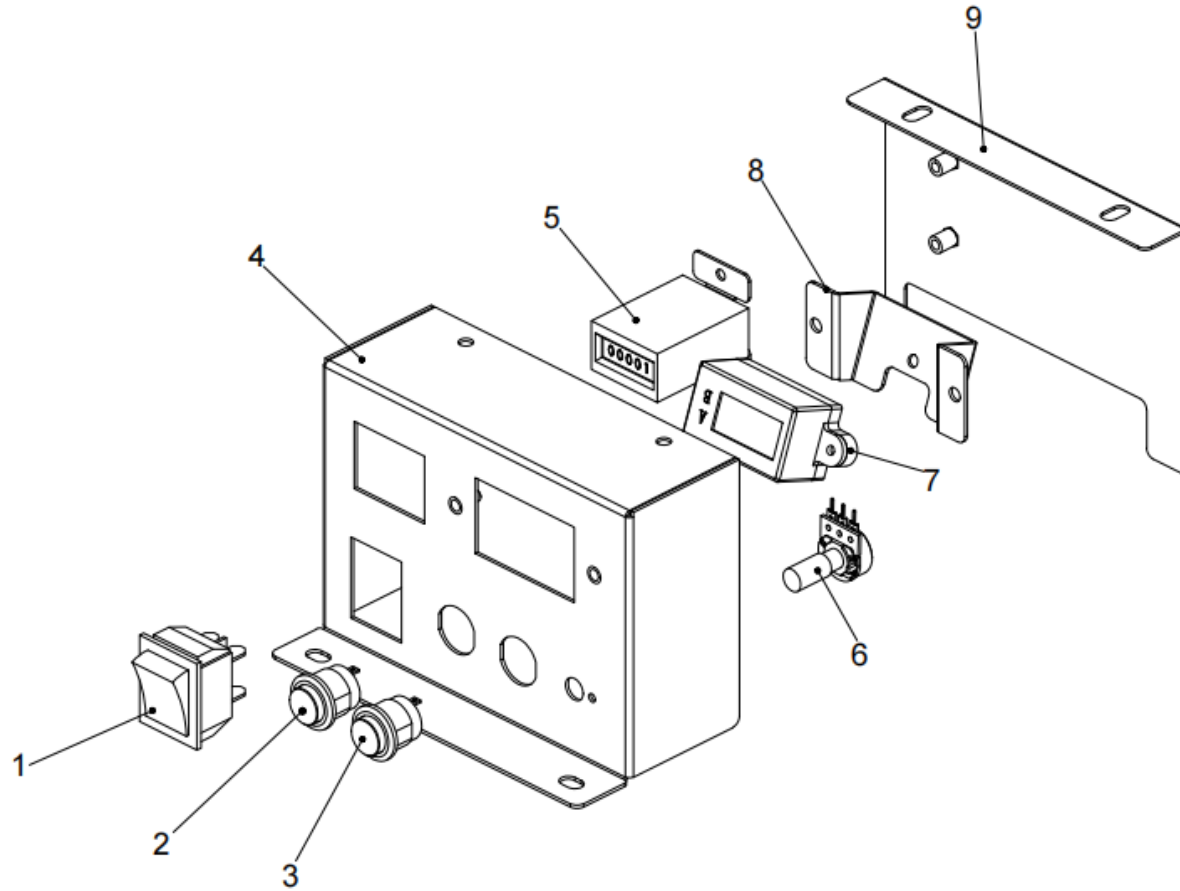

7-Standard Claw Crane

No.	Name	Part Code	Quantity
1	Front & back pulley(no hole)	07.023.058	1
2	Front & back pulley(with hole)	07.023.045	1
3	Left & right slip proof cover	07.023.034	2
4	4E snap ring	01.021.060	5
5	Fixture board-R	07.023.029	1
6	Shaft	07.023.049	1
7	Rubber mat	07.023.221	1
8	Guide rod 1	07.023.042	2
9	Guide rod 2	07.023.043	1
10	Z,PPY micro switch(wheel)	07.023.064	2
11	Z,PPY micro switch(short)	07.023.063	1
12	Micro switch bracket	07.023.033	1
13	Front & back motor fixture board	07.023.030	1
14	Plastic gear wheel	07.023.044	1
15	Guide shaft	07.023.046	1
16	Motor connect board	07.023.036	1
17	Motor	07.023.071	1
18	Motor fixture	07.023.035	1
19	Motor mat	07.023.226	2
20	Left cover	07.023.031	1
21	Wiring cover	07.023.032	1
22	Belt	07.023.066	2
23	Movable motor component	\	1

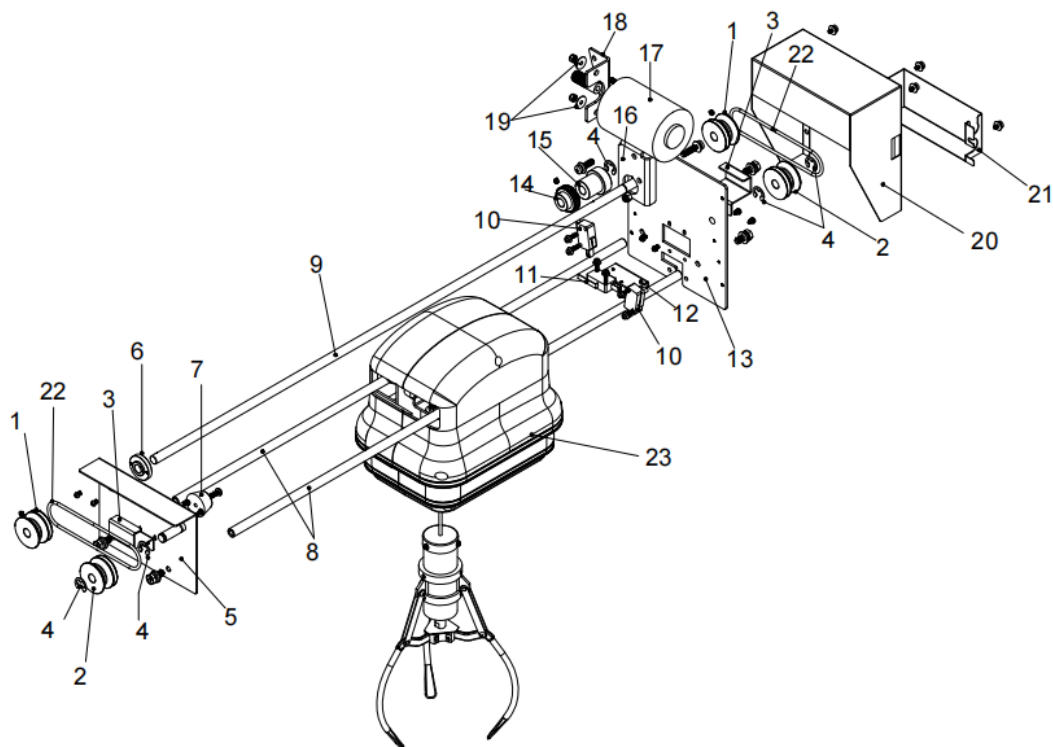

No.	Name	Part Code	Quantity
1	Claw box deco strip-short	\	2
2	Claw box deco strip-long	\	2
3	Front box	01.010.119	1
4	Back box	01.010.120	1
5	Wire hanging wheel	07.023.050	2
6	Φ4 blossom snap ring	01.021.059	3
7	Z,PPY micro switch(arc)	07.023.062	1
8	Anti-shake part	07.023.056	1
9	Spring	07.023.222	1
10	Washer	07.023.223	1
11	Φ4E snap ring	01.021.060	6
12	Spring install board component	07.023.040	1
13	Wire stop strip	07.023.225	2
14	Z,PPY micro switch(wheel)	07.023.064	1
15	Locate plate	07.023.224	1
16	Wire stop torsional spring	07.023.070	1
17	Install Board	07.023.227	1
18	Motor connect board	07.023.228	1
19	Wire locate part	07.023.041	1
20	Motor	07.023.071	2
21	Motor Fixture	07.023.035	2
22	Motor mat	07.023.226	4
23	Left& right pulley(with hole)	07.023.054	2
24	Left& right pulley(no hole)	07.023.057	2
25	Wire roll wheel	07.023.051	1
26	Guide shaft	07.023.046	2
27	Plastic gear wheel	07.023.044	1
28	Iron gear wheel	07.023.047	1
29	Gear wheel shaft 1	07.023.052	1
30	Gear wheel shaft 2	07.023.053	1
31	Seal ring	01.010.142	1
32	Solenoid	07.023.061	1
33	Stand claw	07.023.060	1

7-23-Movable Motor Component

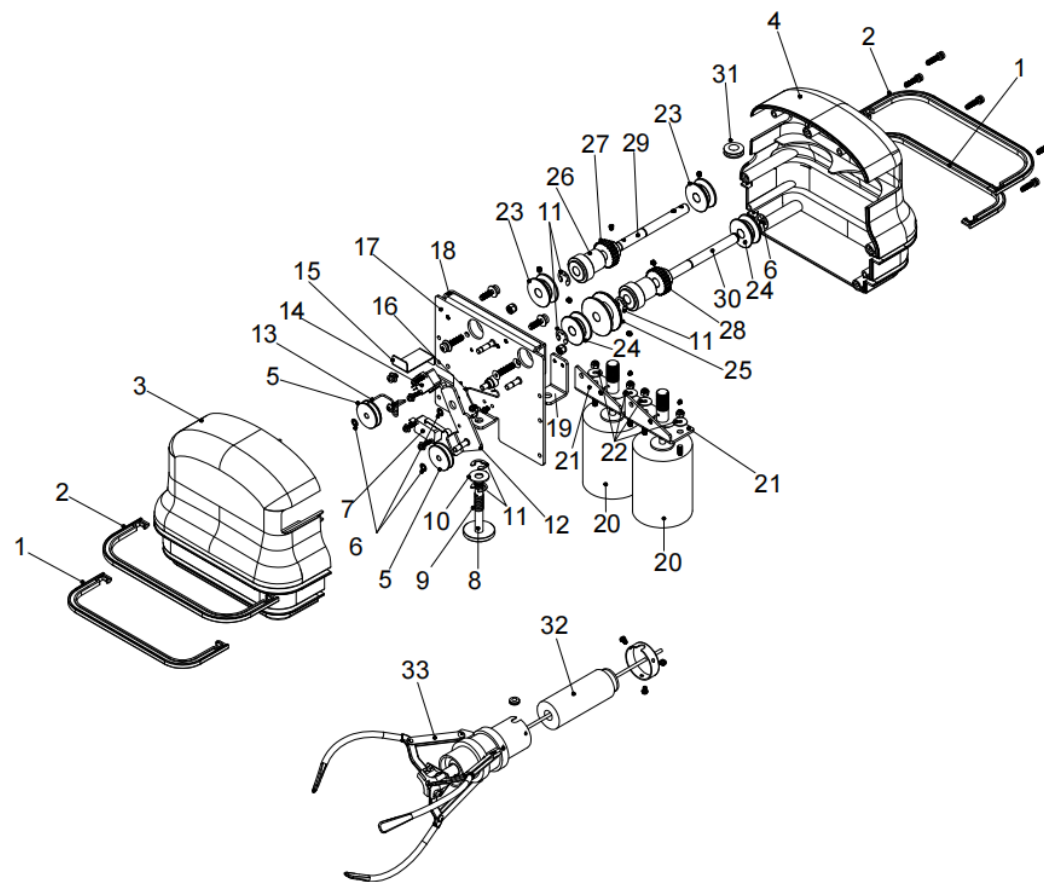

Claw Box Deco Strip-Short

No.	Name	Part Code	Color	Quantity
1	Claw box deco strip-short	01.010.128	Blue	2
2	Claw box deco strip-short	01.010.141	Green	2
3	Claw box deco strip-short	01.010.144	Red	2
4	Claw box deco strip-short	01.010.146	Yellow	2
5	Claw box deco strip-short	01.010.148	Pink	2
6	Claw box deco strip-short	01.010.150	White	2

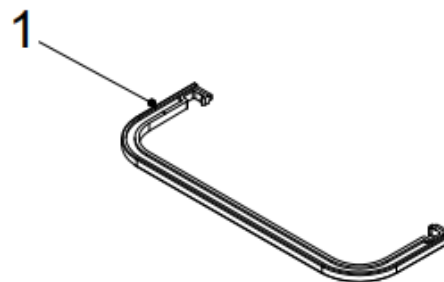

Claw Box Deco Strip-Long

No.	Name	Part Code	Color	Quantity
1	Claw box deco strip-long	01.010.127	Blue	2
2	Claw box deco strip-long	01.010.140	Green	2
3	Claw box deco strip-long	01.010.143	Red	2
4	Claw box deco strip-long	01.010.145	Yellow	2
5	Claw box deco strip-long	01.010.147	Pink	2
6	Claw box deco strip-long	01.010.149	White	2

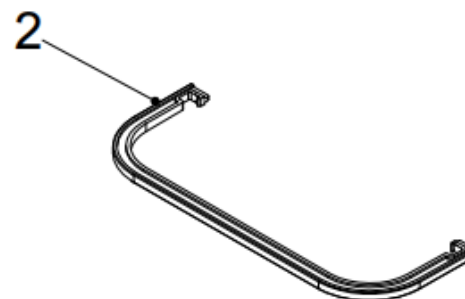

No.	Name	Part Code	Quantity
1	BJ candy claw-right support rod	07.023.323	2
2	BJ candy claw-right side board	07.023.324	1
3	BJ candy claw-right bracket	07.023.325	2
4	BJ candy claw-side cover	07.023.326	1
5	BJ candy claw-left side board	07.023.327	1
6	BJ candy claw-micro switch bracket	07.023.328	1
7	BJ candy claw-left motor bracket	07.023.329	1
8	BJ candy claw-motor bracket	07.023.330	3
9	BJ candy claw-rubber gear wheel	07.023.331	3
10	BJ candy claw-left micro switch	07.023.332	1
11	BJ candy claw-front micro switch	07.023.333	1
12	BJ candy claw-back micro switch	07.023.334	1
13	BJ candy claw-long sleeve suit	07.023.335	3
14	BJ candy claw-double sheave wheel	07.023.336	2
15	BJ candy claw-double sheave wheel with teeth	07.023.337	2
16	BJ candy claw-flat sleeve suit	07.023.338	1
17	BJ candy claw-black belt	07.023.339	2
18	BJ candy claw-8mm steel snap ring	07.023.340	11
19	BJ candy claw-drive rod	07.023.341	1
20	BJ candy claw-big spring tube	07.023.342	1
21	BJ candy claw-small spring tube	07.023.343	1
22	Back cover	01.010.120	1
23	Front cover	01.010.119	1
24	BJ candy claw-middle plate	07.023.344	1
25	BJ candy claw-stop plate	07.023.345	1
26	BJ candy claw-slide block	07.023.346	1
27	BJ candy claw-micro switch mat	07.023.347	1
28	BJ candy claw-middle fixture	07.023.348	1
29	BJ candy claw-short sleeve	07.023.349	1
30	BJ candy claw-short sleeve with groove	07.023.350	1

01.012.039-BJ Candy Claw-1

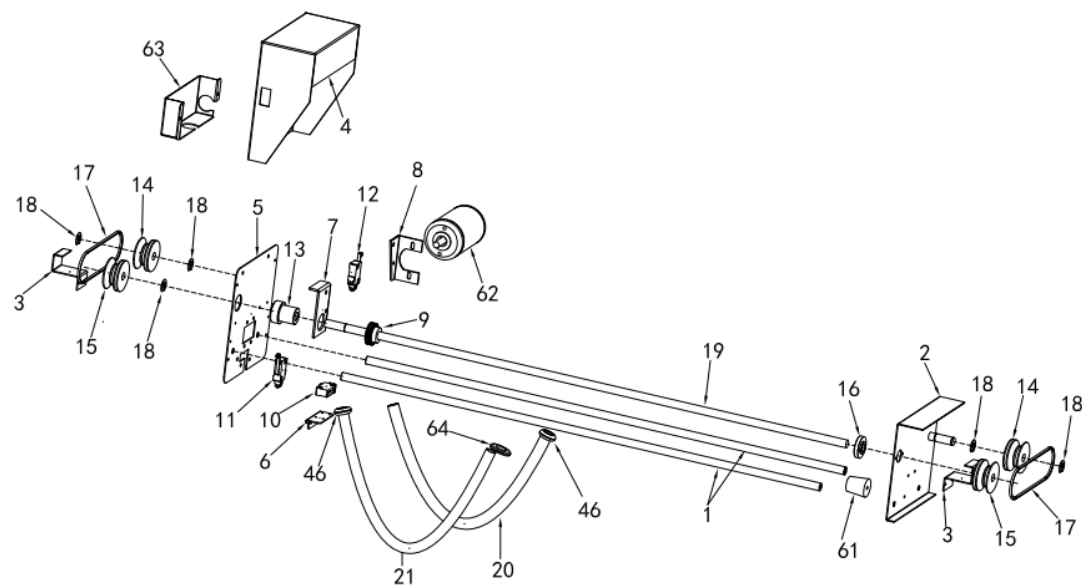

31	BJ candy claw-guide plate	07.023.351	1
32	BJ candy claw-conduit	07.023.352	1
33	BJ candy claw-tube top cover	07.023.353	1
34	BJ candy claw-demagnetize sheet	07.023.354	1
35	BJ candy claw-coil	07.023.355	1
36	BJ candy claw-single sheave wheel	07.023.356	2
37	BJ candy claw-single sheave wheel with teeth	07.023.357	2
38	BJ candy claw-wire wheel	07.023.358	1
39	BJ candy claw-4MM steel snap ring	07.023.359	3
40	BJ candy claw-wire wheel	07.023.360	2
41	Claw box deco strip-Long	01.010.127	2
42	BJ candy claw-5mm bearing clip	07.023.361	1
43	BJ candy claw-spring wire	07.023.362	1
44	BJ candy claw-down micro switch	07.023.363	1
45	BJ candy claw-up micro switch	07.023.364	1
46	BJ candy claw-spring rubber suit	07.023.365	2
47	BJ candy claw-8mm inter sheet	07.023.366	1
48	BJ candy claw-terminal block	07.023.367	1
49	BJ candy claw-connect sheet	07.023.368	3
50	BJ candy claw-steel claw piece	07.023.369	3
51	BJ candy claw-claw feet	07.023.370	3
52	BJ candy claw-suck iron rod	07.023.371	1
53	BJ candy claw-tube inner cover	07.023.372	1
54	BJ candy claw-coil tube	07.023.373	1
55	BJ candy claw-iron fist	07.023.374	2
56	BJ candy claw-claw fixture	07.023.375	1
57	BJ candy claw-adjust plate	07.023.376	1
58	BJ candy claw-guide groove	07.023.377	1
59	BJ candy claw-claw wire	07.023.378	1
60	BJ candy claw-micro switch block	07.023.379	1
61	BJ candy claw-micro switch mat	07.023.380	2

62	BJ candy claw-motor without brake	07.023.381	2
63	BJ candy claw-side box	07.023.382	1
64	BJ candy claw-side box glue suit	07.023.383	1
65	BJ candy claw-up down motor with brake	07.023.384	1
66	BJ candy claw-vortex rod	07.023.385	1
67	BJ candy claw-0.9 press spring	07.023.386	1
68	BJ candy claw-spring wire	07.023.387	1
69	BJ candy claw-claw box deco strip-short	01.010.128	2

01.012.039-BJ Candy Claw-2

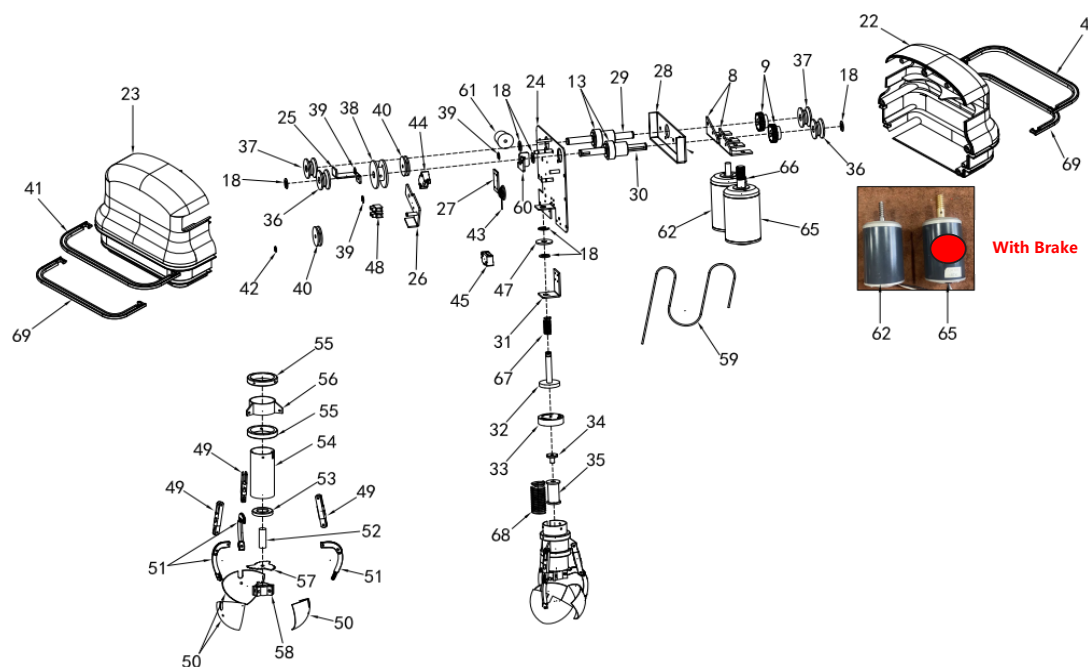

No.	Name	Part Code	Quantity
1A	XML standard claw 700 sub rod	07.023.243	2
2A	XML standard claw 700 main rod	07.023.244	1
3	XML Claw-right side board	07.023.245	1
4	XML Claw-bracket	07.023.246	2
5	XML Claw-side box	07.023.247	1
6	XML Claw-side cover	07.023.248	1
7	XML Claw-left side board	07.023.249	1
8	XML Claw-micro switch bracket	07.023.250	1
9	XML Claw-left motor bracket	07.023.251	1
10	XML Claw-motor bracket	07.023.252	3
11	XML Claw-rubber gear wheel	07.023.253	3
12	Direct current motor 24V-3800RPM without break	01.009.148	2
13	XML Claw-left micro switch	07.023.254	1
14	XML Claw-front & back micro switch	07.023.255	2
15	Direct current motor 24V-3800RPM with break	01.009.147	1
16	XML Claw-long sleeve suit	07.023.256	2
17	XML Claw-double groove wheel	07.023.257	2
18	XML Claw-double groove wheel with teeth	07.023.258	1
19	XML Claw-flat sleeve suit	07.023.259	2
20	XML Claw-green belt	07.023.260	11
21	XML Claw-7mm steel snap ring	07.023.261	1
22A	XML standard Claw-700 big spring tube	07.023.262	1
23A	XML standard claw-700 small spring tube	07.023.263	1
24	XML Claw-16 wire grommet	07.023.264	1
25	XML Claw-14 wire grommet	07.023.265	1
26	XML Claw-11 wire grommet	07.023.266	1
27	XML Claw-middle board	07.023.267	1
28	XML Claw-stop board	07.023.268	1
29	XML Claw-slide brick	07.023.269	1
30	XML Claw-micro switch mat	07.023.270	1
31	XML Claw-middle fixture	07.023.271	1

01.012.037 XML Standard Claw-1

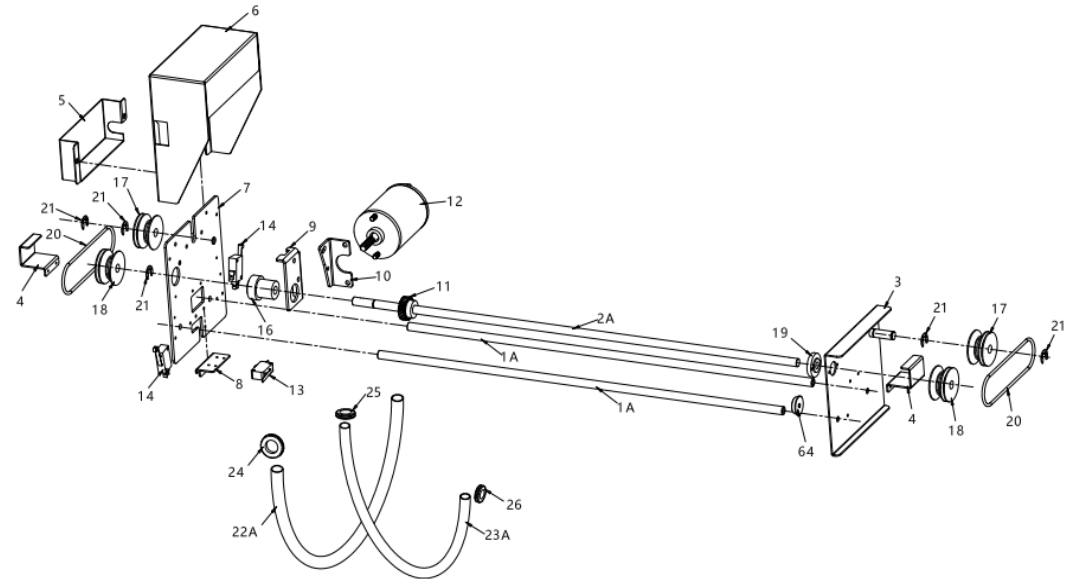

32	XML Claw-short sleeve	07.023.272	1
33	XML Claw-short sleeve with groove	07.023.273	1
34	XML Claw-guide board	07.023.274	1
35	XML Claw-wire tube	07.023.275	1
36A	XML Standard Claw-tube top cover	07.023.276	1
37	XML Claw-demagnetize sheet	07.023.277	1
38A	XML Standard Claw-wire ring	07.023.278	1
39	XML Claw-0.9 press spring	07.023.279	1
40	XML Claw-single groove wheel with teeth	07.023.280	2
41	XML Claw-single groove wheel	07.023.281	2
42	XML Claw-rope wheel	07.023.282	1
43	XML Claw-4mm steel snap ring	07.023.283	2
44	XML Claw-rope wheel	07.023.284	2
45	XML Claw-wheel stop rod	07.023.285	1
46	XML Claw-5 bearing clip	07.023.286	1
47	XML Claw-1.1 torsional spring	07.023.287	1
48	XML Claw-terminal block	07.023.288	1
49	XML Claw-down micro switch	07.023.289	1
50	XML Claw-up micro switch	07.023.290	1
51	XML Claw-claw glove	07.023.291	3
52	XML Claw-8mm flat sheet	07.023.292	1
53A	XML Standard Claw-iron ring	07.023.293	2
54A	XML Standard Claw-claw fixture	07.023.294	1
55A	XML Standard Claw-connect plate	07.023.295	3 pairs
56A	XML Standard Claw-steel tube	07.023.296	1
57A	XML Standard Claw-tube inner cover	07.023.297	1
58A	XML Standard Claw-Magnetic absorb bar	07.023.298	1
59A	XML Standard Claw-claw feet	07.023.299	3
60A	XML Standard Claw-triangle plate	07.023.300	1
61A	XML Standard Claw-guide groove	07.023.301	1
62	XML Claw-rope	07.023.302	1

63	XML Claw-spring wire	07.023.303	1
64	XML Claw- anti-collision rubber	07.023.304	2
65	XML Claw- anti-collision brick	07.023.305	1
66	XML Claw-front box	01.010.119	1
67	XML Claw-back box	01.010.120	1
68	XML Claw-long blue strip	01.010.127	2
69	XML Claw-short blue strip	01.010.128	2

01.012.037 XML Standard Claw-2

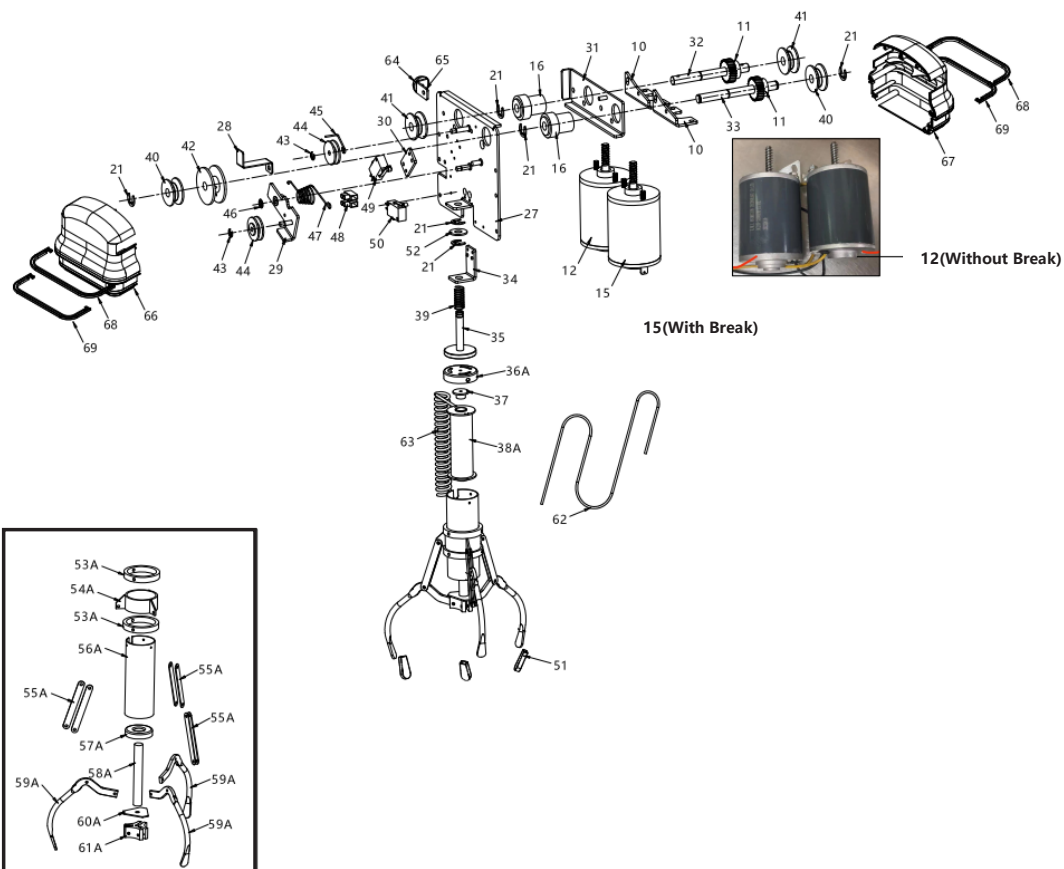

PARTS LIST (CAPTO CRANE MIDI)

No.	Name	Part Code	Quantity
1	Cabinet	Diagram1-Cabinet	1
2	Glass Door Assembly	Diagram2-Glass Door Assembly	1
3	Cash Machine Frame Assembly	Diagram3-Cash Machine Frame Assembly	1
4	Console Sheet Metal Assembly	Diagram4-Console Sheet Metal Assembly	1
5	Coin Box	Diagram5-coin box	1
6	Service Panel	Diagram6-Service Panel	1
7	Middle Size Crane Assembly	01.012.001	1
8	Chassis Power Supply	01.005.012	1
9	Light Strip Power Supply	01.005.013	1
10	Name Plate	\	1
11	\	\	\
12	NO:7	06.028.007	1
13	NO.8	06.028.080	1
14	Sensor Board	01.019.058	1
15	Carpet	01.015.039	1
16	Power Box Cover NO:14	06.028.082	1
17	Rear Small Door	07.023.215	1
18	Anti-Shake Device	01.016.015	1
19	Power Box Assembly	Diagram17-Power Supply Box Assembly	1

Overview

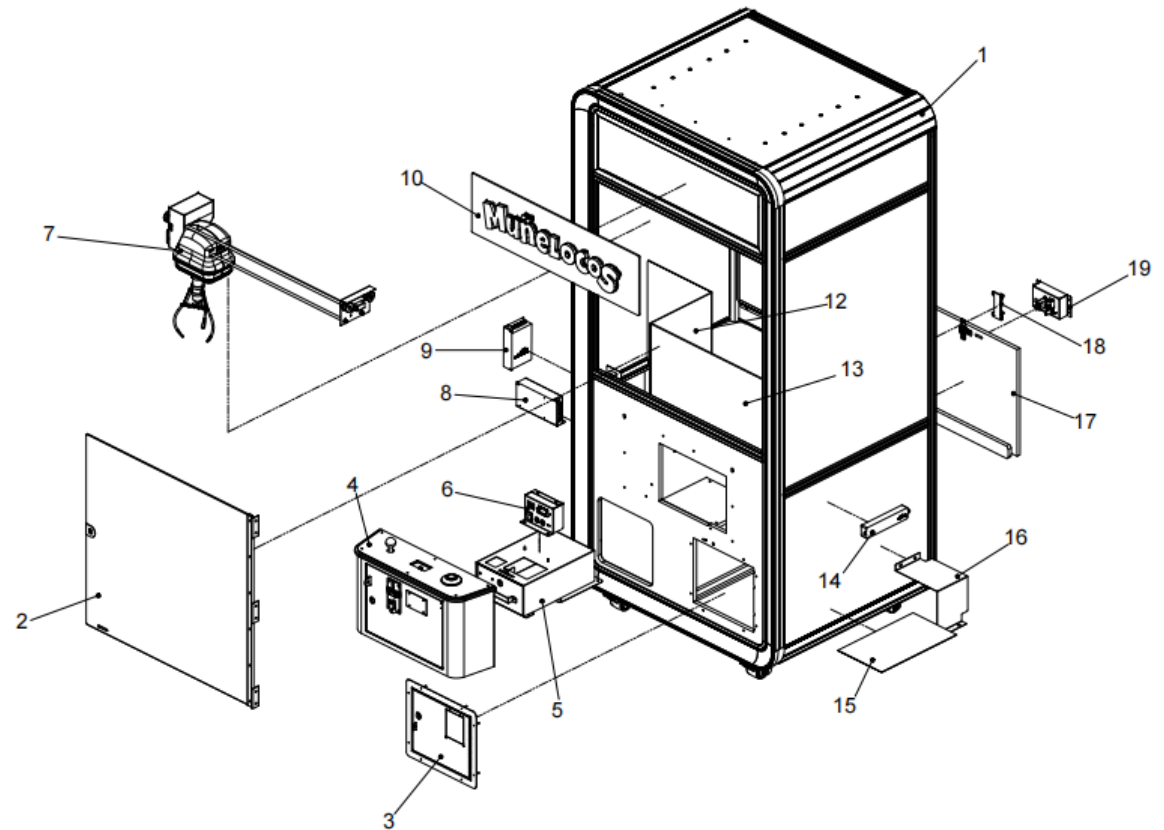

No.	Name	Part Code	Quantity
1	Coin Acceptor Panel	\	1
2	Bill Validator Cover Plate	07.023.205	1
3	Console Door Panel	07.023.004	1
4	Console Sheet Metal Weldment	07.023.024	1
5	Speaker	01.016.008	1
6	Console Panel	07.023.005	1
7	NO:6	06.028.006	1
8	\	\	1
9	Joystick - B	01.008.030	1
10	LCD Panel	01.002.009	1
11	White Rainbow Button	01.008.020	1

Diagram4-Console Sheet Metal Assembly

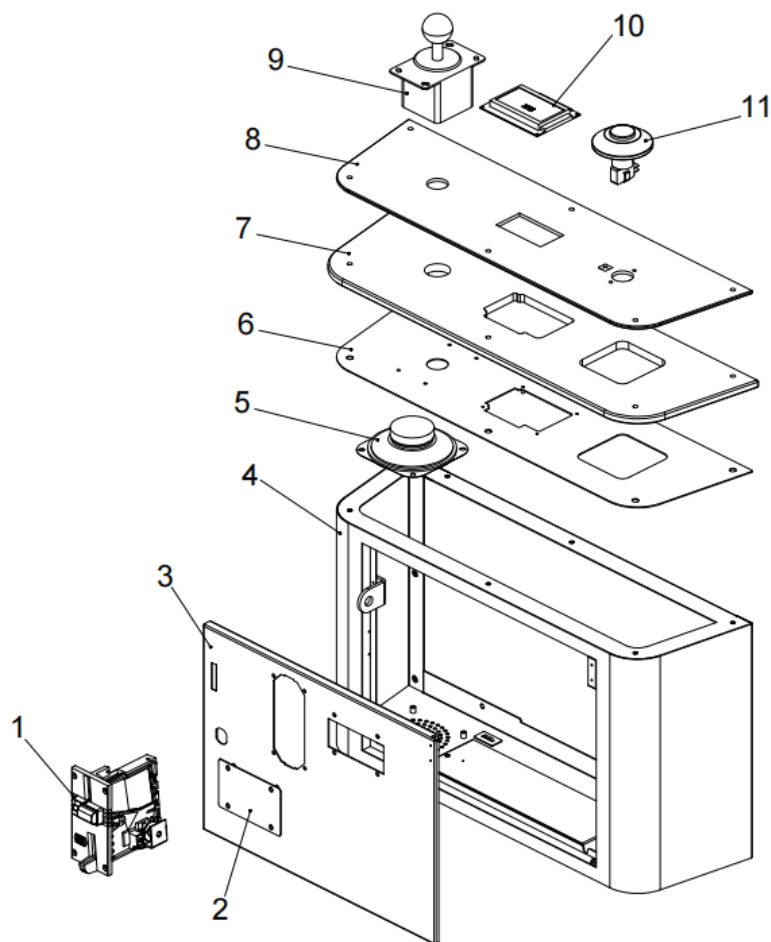

No.	Name	Part Code	Quantity
1	Glass Door Panel	07.023.206	1
2	Glass Door Hinge 1	07.023.083	1
3	Mirror Finish Stainless Steel Glass Door Hinge Press Strip	07.023.014	1
4	Hinge Rod 1	07.023.199	1
5	Glass Door Hinge 2	07.023.082	3
6	Mirror Finish Stainless Steel Glass Door Lock Plate	07.023.013	1

Diagram2-Glass Door Assembly

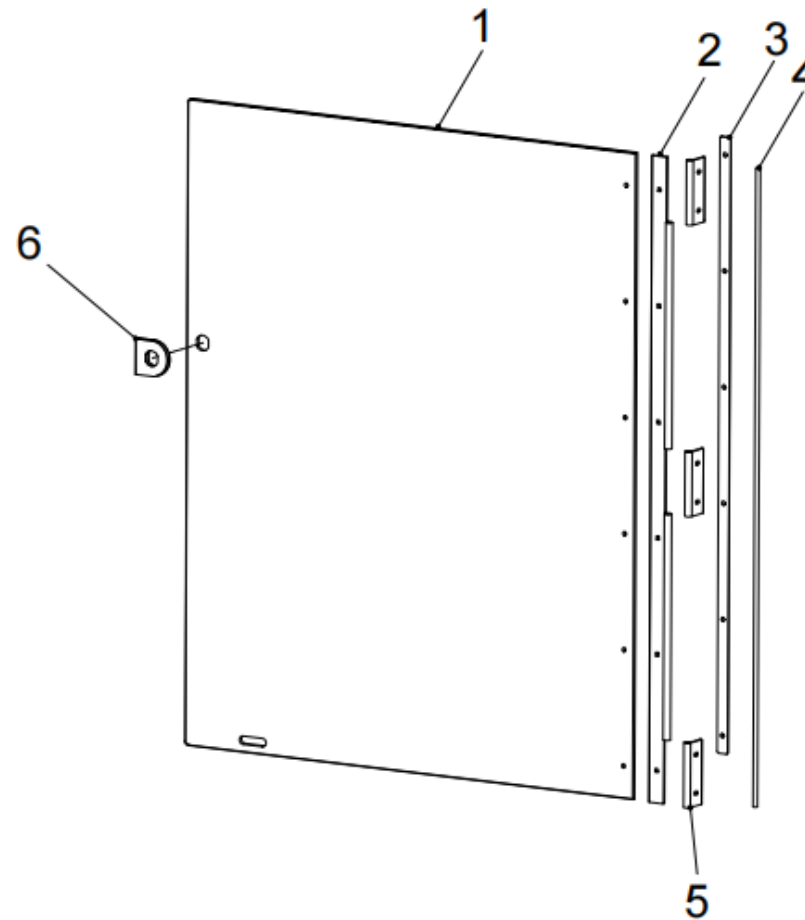

No.	Name	Part Code	Quantity
1	Door Panel Sheet Metal Weldment	07.023.171	1
2	Bill Validator Cover Plate - 2	07.023.176	1
3	Door Panel Frame	07.023.172	1

Diagram3-Cash Machine Frame Assembly

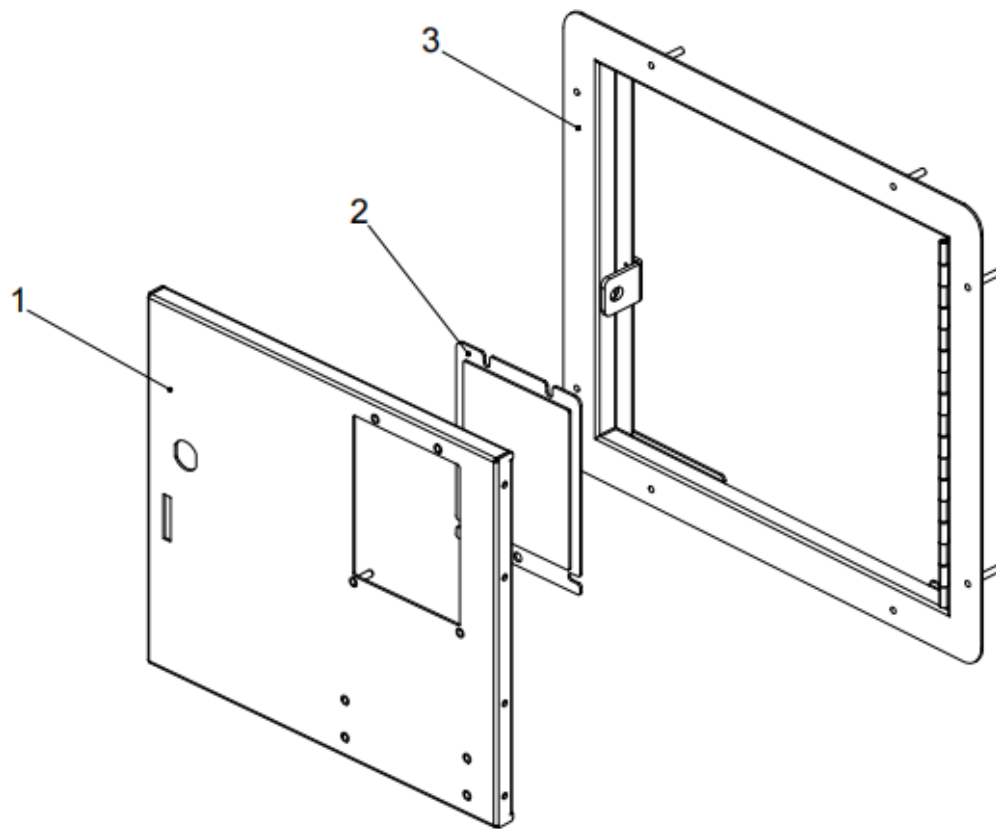

No.	Name	Part Code	Quantity
1	Universal Fuse Holder	01.016.004	1
2	Universal Power Switch	01.016.003	1
3	Filter	01.016.102	1
4	Power Switch Box	07.023.140	1

Diagram:17-Power Supply Box Assembly

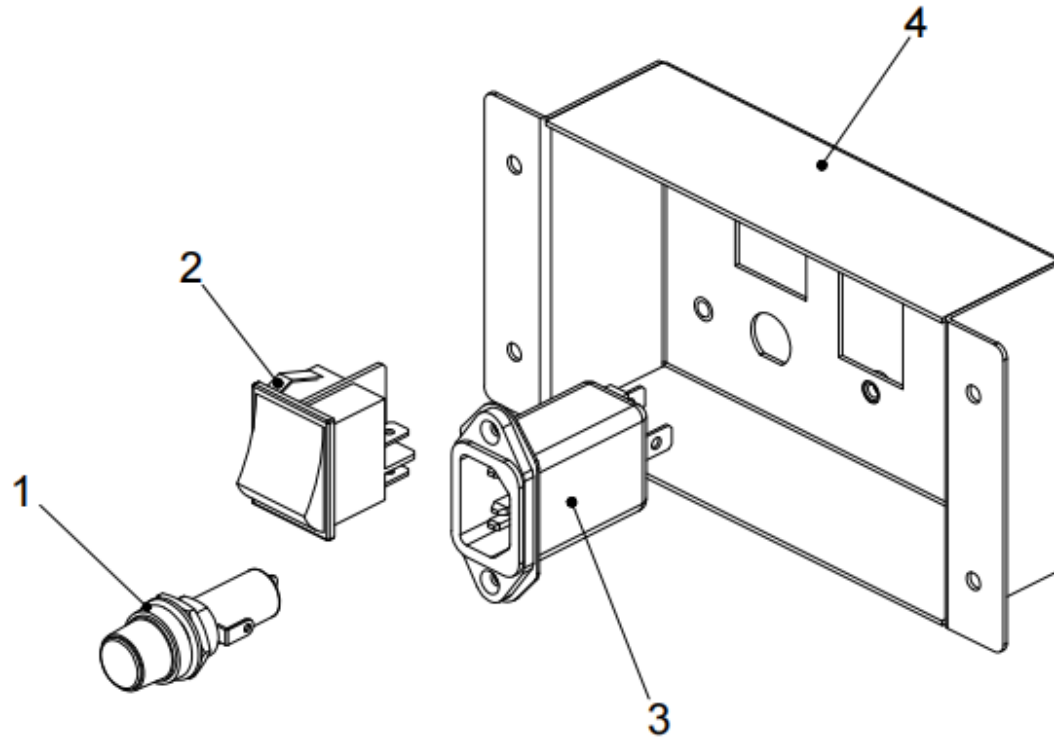

No.	Name	Part Code	Quantity
1	Universal Power Switch	01.016.003	1
2	Universal Setting Button - Red	01.008.017	1
3	Universal Setting Button - Green	01.008.015	1
4	Service Panel	07.023.148	1
5	Mechanical Tachometer	01.016.032	1
6	Knob Switch	01.016.101	1
7	Universal Electronic Tachometer	01.016.051	1
8	Digital meter Bracket	07.023.147	1
9	Service Panel Cover Plate	07.023.010	1

Diagram6-Service Panel

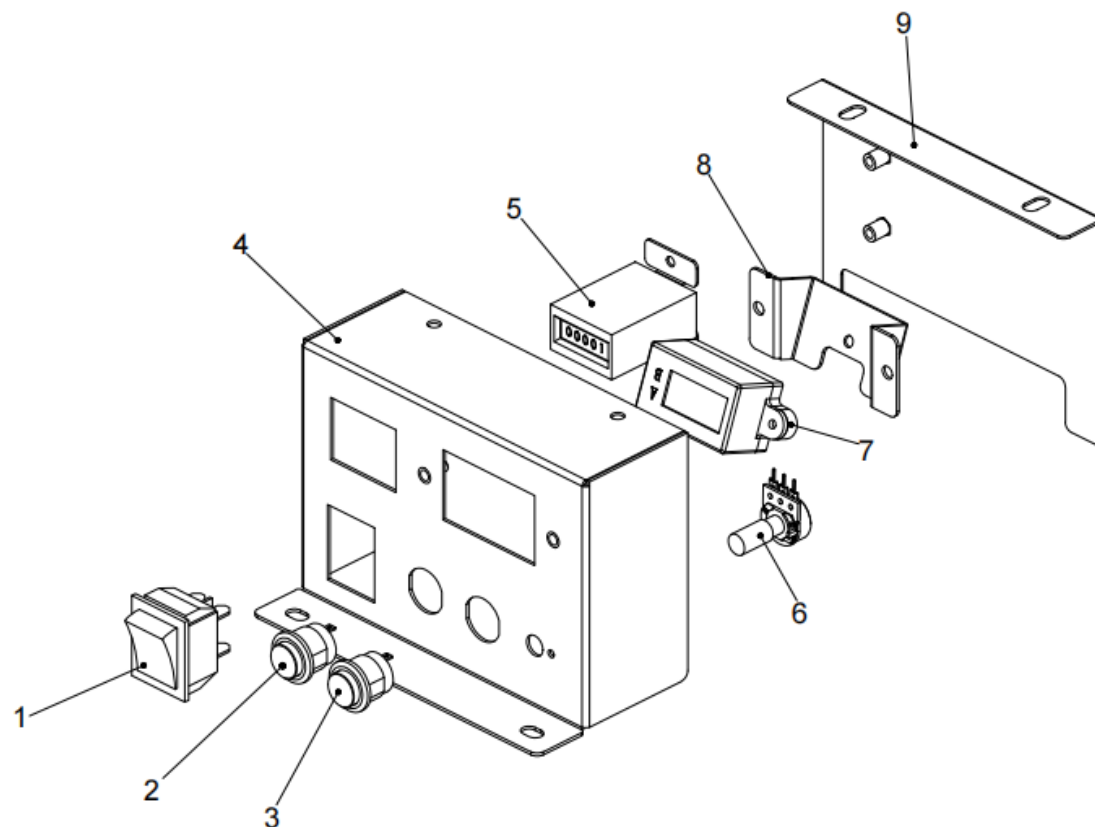

No.	Name	Part Code	Quantity
1	Drawer Box	07.023.028	1
2	Coin Box	07.023.027	1

Diagram5-Coin Box

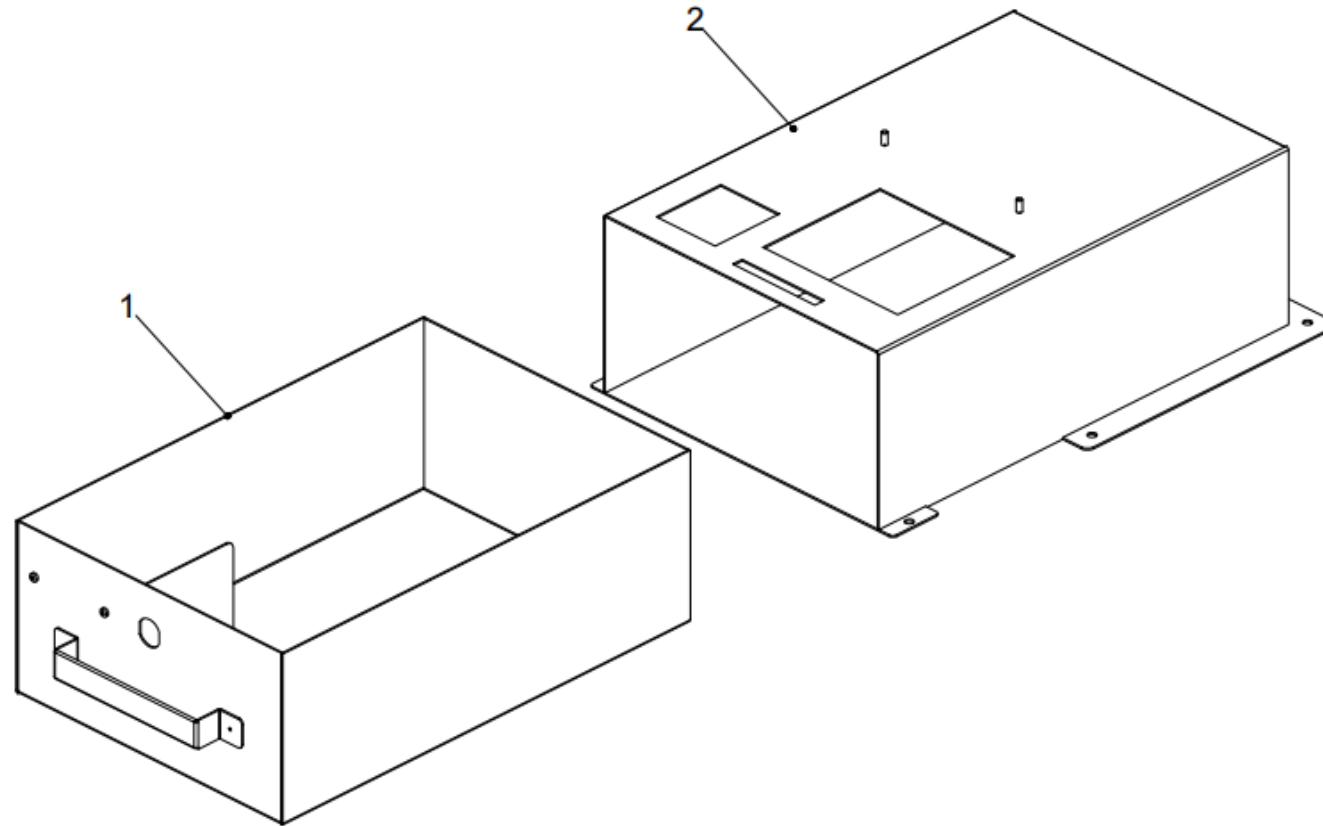

No.	Name	Part Code	Quantity
1	Front & back pulley(no hole)	07.023.058	1
2	Front & back pulley(with hole)	07.023.045	1
3	Left & right slip proof cover	07.023.034	2
4	4E snap ring	01.021.060	5
5	Fixture board-R	07.023.029	1
6	Shaft	07.023.049	1
7	Rubber mat	07.023.221	1
8	Middle size claw-guide rod 1 841.4mm	07.023.231	2
9	Middle size claw-Guide rod 2 841.4mm	07.023.232	1
10	Z,PPY micro switch(wheel)	07.023.064	2
11	Z,PPY micro switch(short)	07.023.063	1
12	Micro switch bracket	07.023.033	1
13	Front & back motor fixture board	07.023.030	1
14	Plastic gear wheel	07.023.044	1
15	Guide shaft	07.023.046	1
16	Motor connect board	07.023.036	1
17	Motor	07.023.071	1
18	Motor fixture	07.023.035	1
19	Motor mat	07.023.226	2
20	Left cover	07.023.031	1
21	Wiring cover	07.023.032	1
22	Belt	07.023.066	2
23	Movable motor component	\	1

7-Middle Size Claw

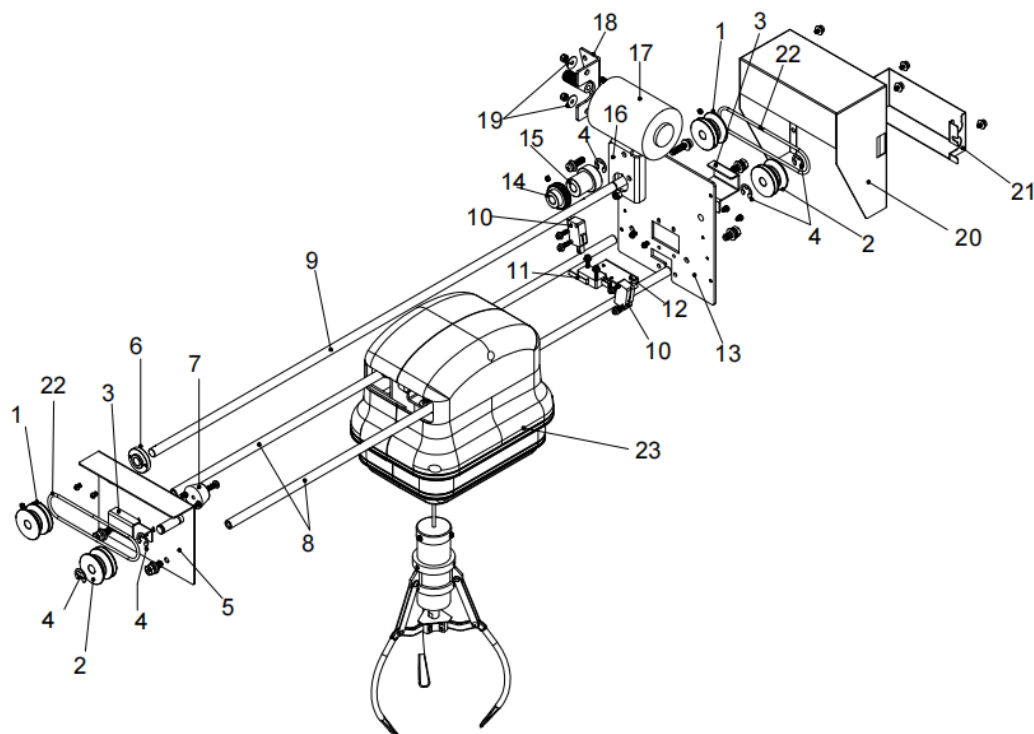

No.	Name	Part Code	Quantity
1	Claw box deco strip-short	\	2
2	Claw box deco strip-long	\	2
3	Front box	01.010.119	1
4	Back box	01.010.120	1
5	Wire hanging wheel	07.023.050	2
6	Φ4 blossom snap ring	01.021.059	3
7	Z,PPY micro switch(arc)	07.023.062	1
8	Anti-shake part	07.023.056	1
9	Spring	07.023.222	1
10	Washer	07.023.223	1
11	Φ4E snap ring	01.021.060	6
12	Spring install board component	07.023.040	1
13	Wire stop strip	07.023.225	2
14	Z,PPY micro switch(wheel)	07.023.064	1
15	Locate plate	07.023.224	1
16	Wire stop torsional spring	07.023.070	1
17	Install Board	07.023.227	1
18	Motor connect board	07.023.228	1
19	Wire locate part	07.023.041	1
20	Motor	07.023.071	2
21	Motor Fixture	07.023.035	2
22	Motor mat	07.023.226	4
23	Left& right pulley(with hole)	07.023.054	2
24	Left& right pulley(no hole)	07.023.057	2
25	Wire roll wheel	07.023.051	1
26	Guide shaft	07.023.046	2
27	Plastic gear wheel	07.023.044	1
28	Iron gear wheel	07.023.047	1
29	Gear wheel shaft 1	07.023.052	1
30	Gear wheel shaft 2	07.023.053	1
31	Seal ring	01.010.142	1
32	Solenoid	07.023.061	1
33	Middle Size Claw	01.016.024	1

7-23-Movable Motor Component

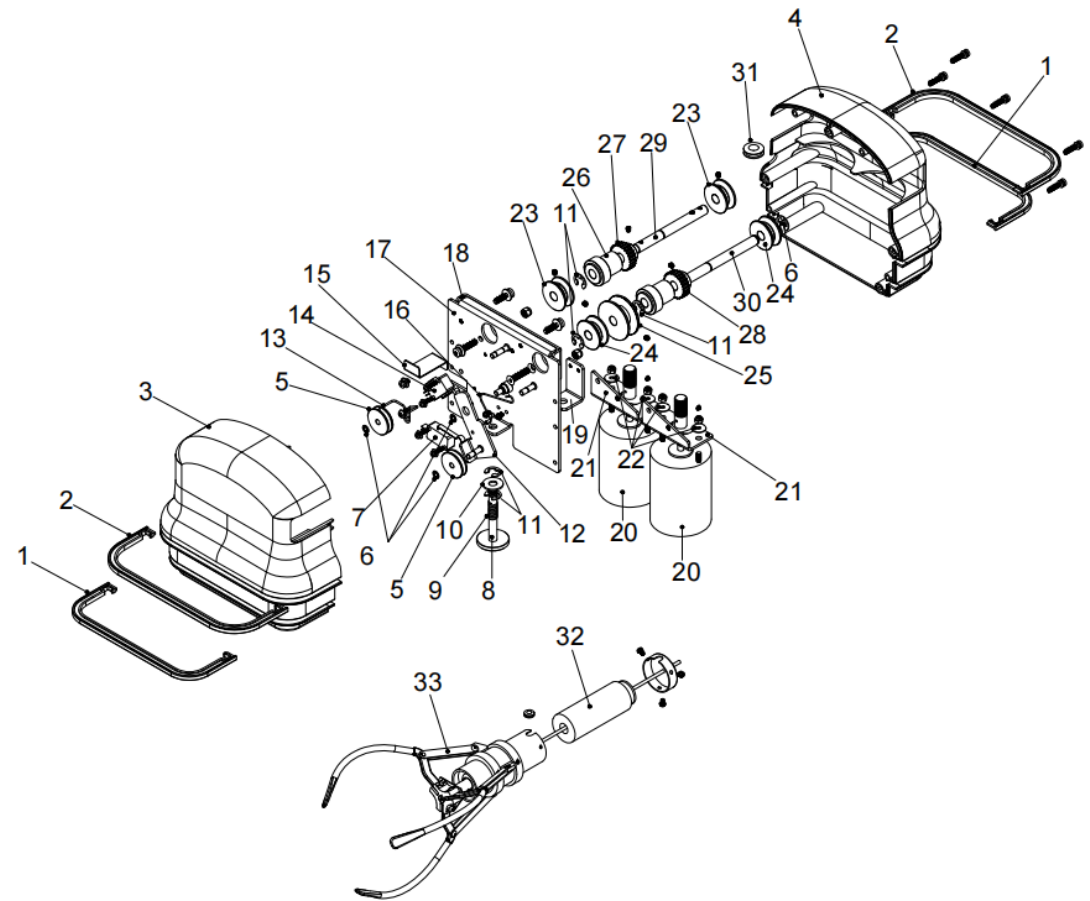

Claw Box Deco Strip-Short

No.	Name	Part Code	Color	Quantity
1	Claw box deco strip-short	01.010.128	Blue	2
2	Claw box deco strip-short	01.010.141	Green	2
3	Claw box deco strip-short	01.010.144	Red	2
4	Claw box deco strip-short	01.010.146	Yellow	2
5	Claw box deco strip-short	01.010.148	Pink	2
6	Claw box deco strip-short	01.010.150	White	2



Claw Box Deco Strip-Long

No.	Name	Part Code	Color	Quantity
1	Claw box deco strip-long	01.010.127	Blue	2
2	Claw box deco strip-long	01.010.140	Green	2
3	Claw box deco strip-long	01.010.143	Red	2
4	Claw box deco strip-long	01.010.145	Yellow	2
5	Claw box deco strip-long	01.010.147	Pink	2
6	Claw box deco strip-long	01.010.149	White	2

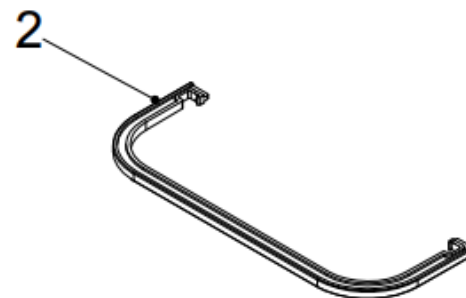

No.	Name	Part Code	Quantity
1B	XML middle size claw-884 sub rod	07.023.308	2
2B	XML middle size claw-884 main rod	07.023.309	1
3	XML middle size claw-right side board	07.023.245	1
4	XML middle size claw-bracket	07.023.246	2
5	XML middle size claw-side box	07.023.247	1
6	XML middle size claw-side cover	07.023.248	1
7	XML middle size claw-left side board	07.023.249	1
8	XML middle size claw-micro switch bracket	07.023.250	1
9	XML middle size claw-left motor bracket	07.023.251	1
10	XML middle size claw-motor bracket	07.023.252	3
11	XML middle size claw-rubber gear wheel	07.023.253	3
12	Direct current motor 24V-3800RPM without break	01.009.148	2
13	XML middle size claw-left micro switch	07.023.254	1
14	XML middle size claw-front & back micro switch	07.023.255	2
15	Direct current motor 24V-3800RPM with break	01.009.147	1
16	XML middle size claw-long sleeve suit	07.023.256	3
17	XML middle size claw-double groove wheel	07.023.257	1
18	XML middle size claw-double groove wheel with teeth	07.023.258	1
19	XML middle size claw-flat sleeve suit	07.023.259	1
20	XML middle size claw-green belt	07.023.260	2
21	XML middle size claw-7mm steel snap ring	07.023.261	11
22B	XML middle size claw-884 big spring tube	07.023.310	1
23B	XML middle size claw-884 small spring tube	07.023.311	1
24	XML middle size claw-16 wire grommet	07.023.264	1
25	XML middle size claw-14 wire grommet	07.023.265	1
26	XML middle size claw-11 wire grommet	07.023.266	1

01.012.038-XML Middle Size Claw-1

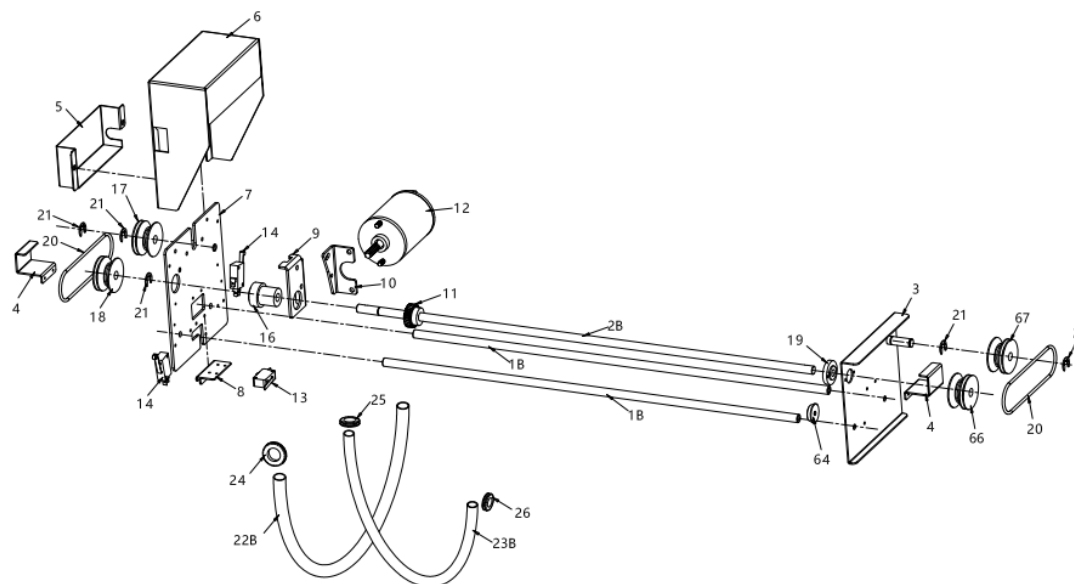

No.	Name	Part Code	Quantity
27	XML Claw-middle board	07.023.267	1
28	XML Claw-stop board	07.023.268	1
29	XML Claw-slide brick	07.023.269	1
30	XML Claw-micro switch mat	07.023.270	1
31	XML Claw-middle fixture	07.023.271	1
32	XML Claw-short sleeve	07.023.272	1
33	XML Claw-short sleeve with groove	07.023.273	1
34	XML Claw-guide board	07.023.274	1
35	XML Claw-wire tube	07.023.275	1
36B	XML Claw-tube top cover	07.023.312	1
38B	XML Claw-wire ring	07.023.313	1
39	XML Claw-0.9 press spring	07.023.279	1
40	XML Claw-single groove wheel with teeth	07.023.280	2
41	XML Claw-single groove wheel	07.023.281	2
42	XML Claw-rope wheel	07.023.282	1
43	XML Claw-4mm steel snap ring	07.023.283	2
44	XML Claw-rope wheel	07.023.284	2
45	XML Claw-wheel stop rod	07.023.285	1
46	XML Claw-5 bearing clip	07.023.286	1
47	XML Claw-1.1 torsional spring	07.023.287	1
48	XML Claw-terminal block	07.023.288	1
49	XML Claw-down micro switch	07.023.289	1
50	XML Claw-up micro switch	07.023.290	1
51	XML Claw-claw glove	07.023.291	3
52	XML Claw-8mm flat sheet	07.023.292	1
53B	XML Middle Size Claw-iron ring	07.023.314	2
54B	XML Middle Size Claw-claw fixture	07.023.315	1
55B	XML Middle Size Claw-connect plate	07.023.316	3 对
56B	XML Middle Size Claw-steel tube	07.023.317	1
57B	XML Middle Size Claw-tube inner cover	07.023.318	1
58B	XML Middle Size Claw-Magnetic absorb bar	07.023.319	1
59B	XML Middle Size Claw-claw feet	07.023.320	3
60B	XML Middle Size Claw-triangle plate	07.023.321	1

61B	XML Middle Size Claw-guide groove	07.023.322	1
62	XML Claw-rope	07.023.302	1
63	XML Claw-spring wire	07.023.303	1
64	XML Claw- anti-collision rubber	07.023.304	2
65	XML Claw- anti-collision brick	07.023.305	1
66	XML Claw-front right wheel-big	07.023.306	1
67	XML Claw-back right wheel-big	07.023.307	1
68	Front box	01.010.119	1
69	Back box	01.010.120	1
70	long blue strip	01.010.127	2
71	short blue strip	01.010.128	2

01.012.038-XML Middle Size Claw-2

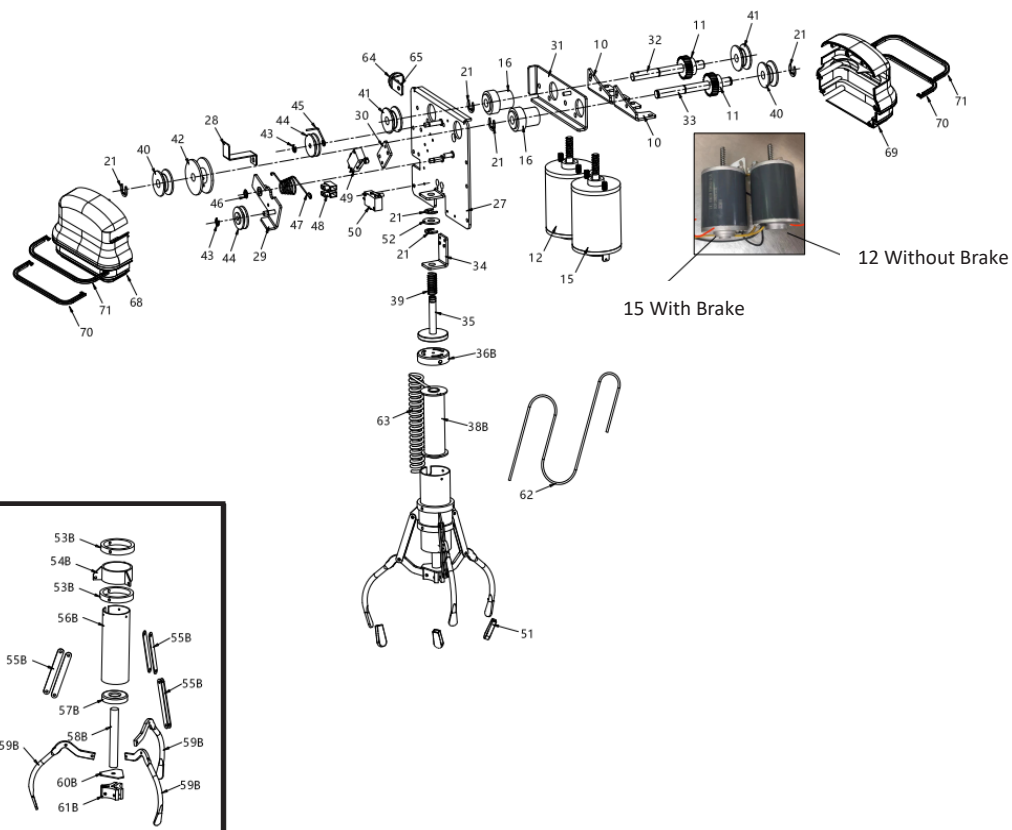

SCHEMATIC DIAGRAMS

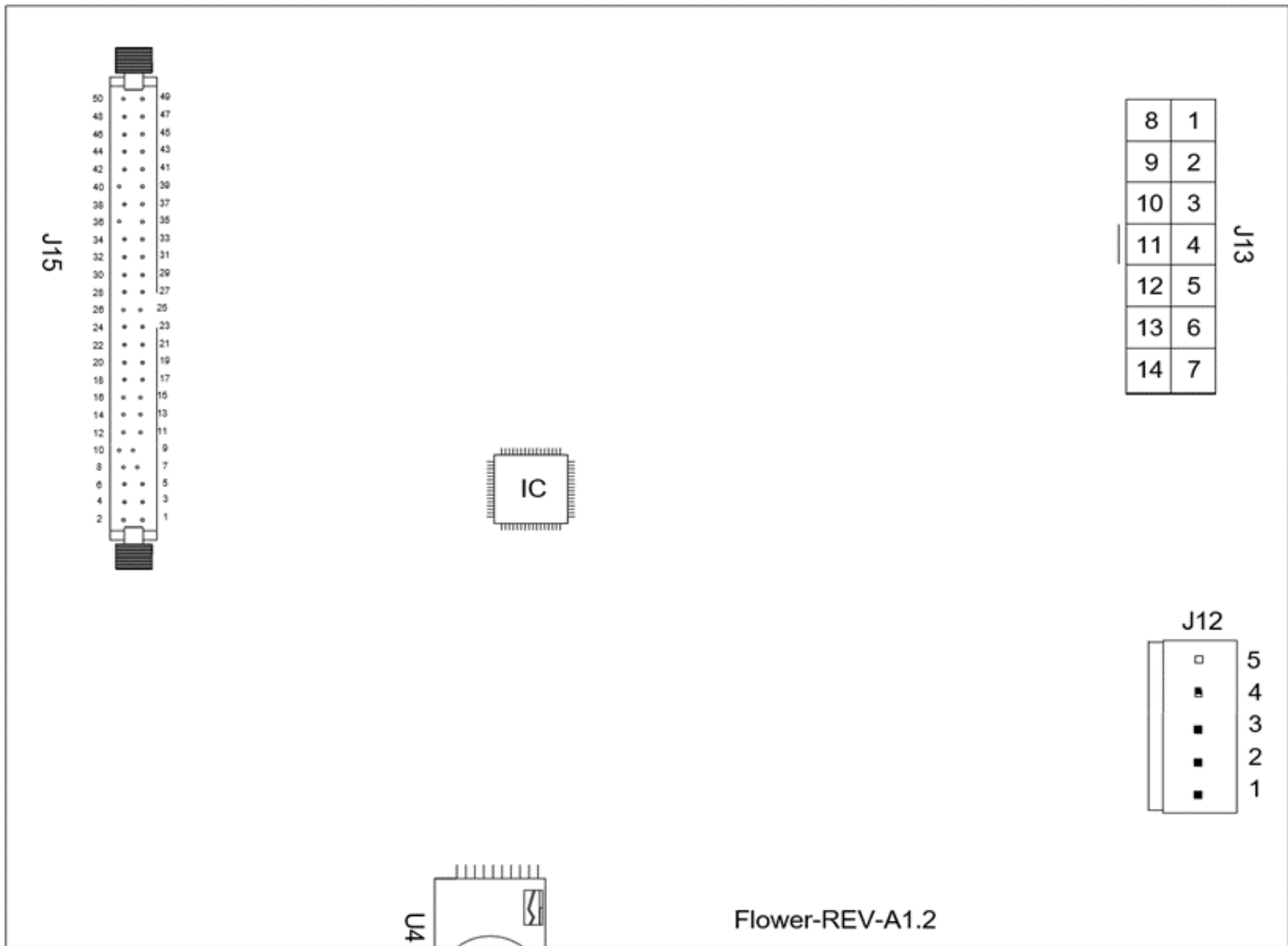

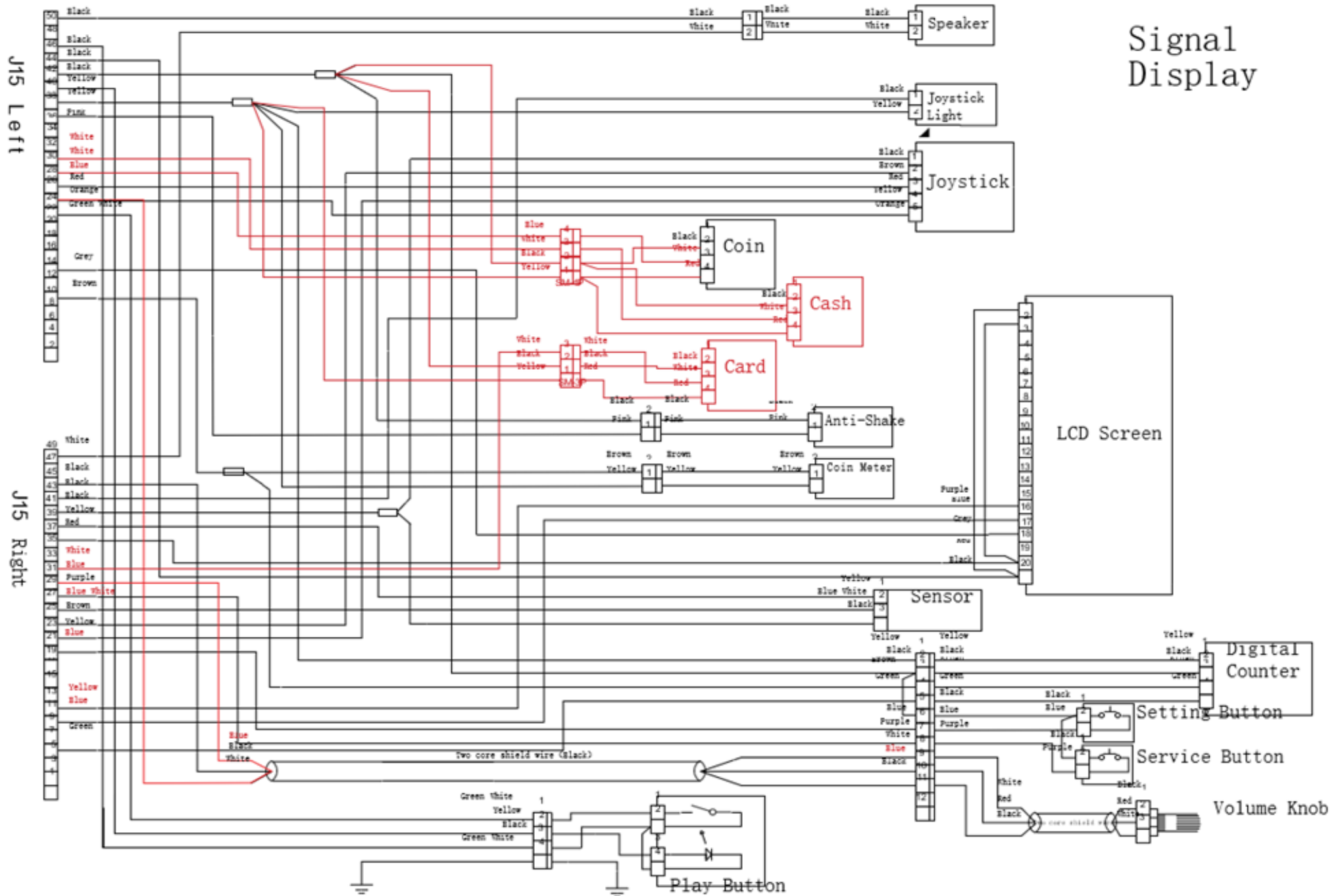

Crane

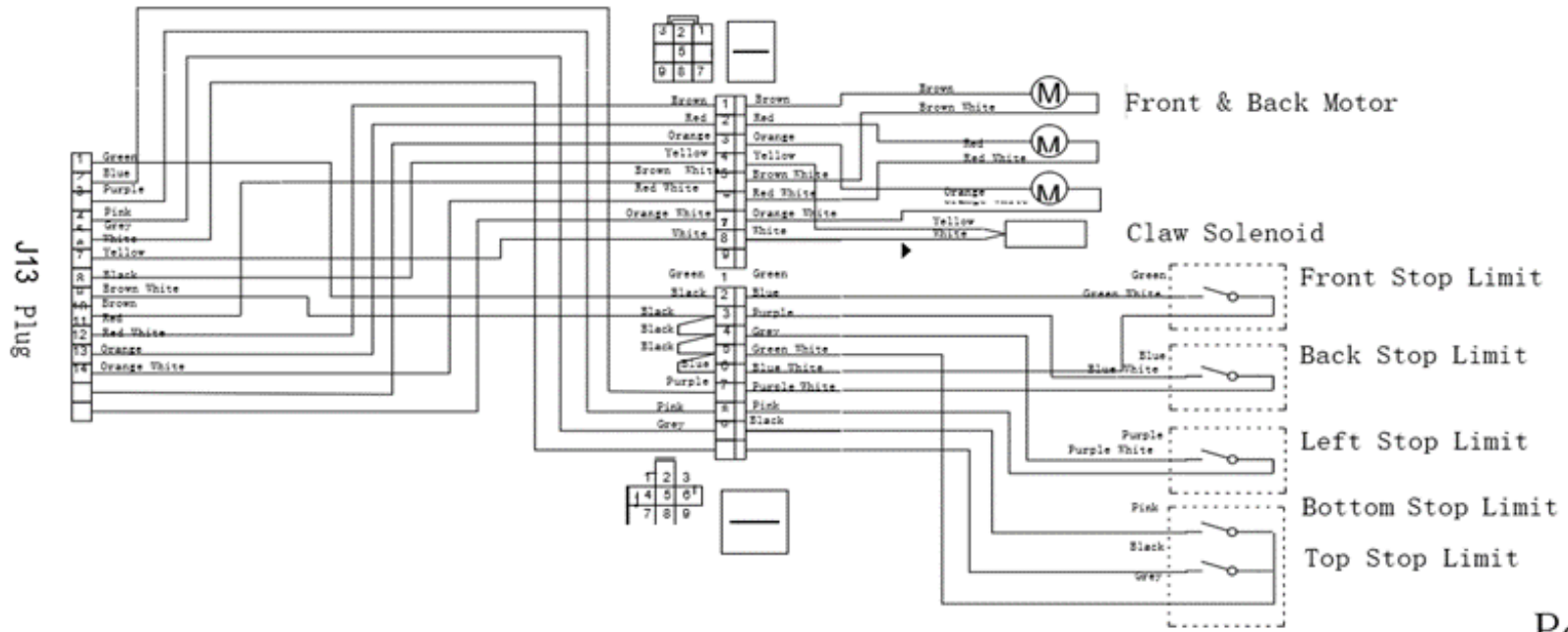

Power Supply

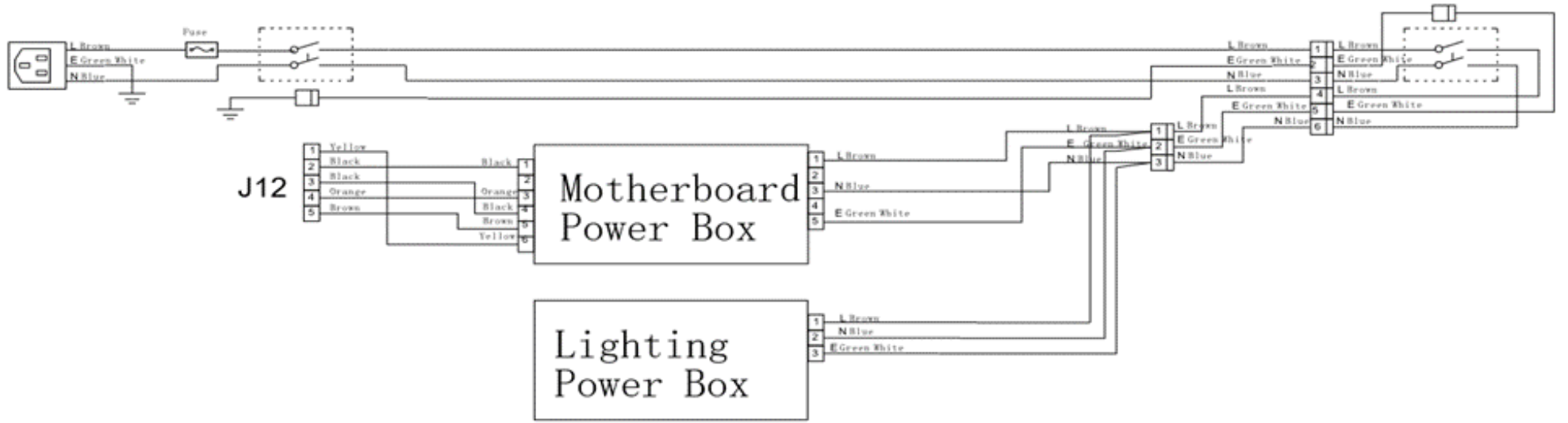

SPARES AND SERVICE CONTACT INFORMATION



- SEGA TOTAL SOLUTIONS -

42 Barwell Business Park
Leatherhead Road,
Chessington,
Surrey,
KT9 2NY
United Kingdom

Parts: +44 (0) 2083918060
stssales@segaarcade.com

- TECHNICAL SUPPORT -

+44 (0) 2083918060
technical@segaarcade.com

- PLAY IT AMUSEMENTS -

870 Lively Blvd
Wood Dale,
IL,
602191
United States of America

Parts/Customer Service: +00 (1) 224 265 4287
Technical Support: +00 (1) 224 265 4283
PIA: support@playitamusements.com

