

420-0040UK
1ST PRINTING



SEGA AMUSEMENTS INTERNATIONAL LTD.

42 Barwell Business Park, Leatherhead Road
Chessington, Surrey
KT9 2NY
United Kingdom

Telephone: +44 (0) 208 391 8090 Facsimile: +44 (0) 208 391 8099
Email: sales@segaarcade.com Web: <http://www.segaarcade.com>

© Kaizen Entertainment

Errors & Omissions Excepted (E&OE)

BOP IT ARCADE

OWNER'S MANUAL

420-0040UK



SERVICE MANUAL



IMPORTANT

- Before using this product, read this Manual carefully to understand the contents herein stated
- After reading this Manual, be sure to keep it near the product or in a convenient place for easy reference when necessary

BEFORE USING THE PRODUCT, BE SURE TO READ THE FOLLOWING:

TO MAINTAIN SAFETY:

To ensure the safe operation of this product, be sure to read the following before usage:

The following instructions are intended for the users, operators and the personnel in charge of the operation of the product. After carefully reading and sufficiently understanding the warning displays and cautions, handle the product appropriately. Be sure to keep this manual close to the product or in a convenient place for future reference.

Herein, explanations which require special attention are enclosed with dual lines. Depending on the potentially hazardous degrees, the terms of "**DANGER**", "**WARNING**", "**CAUTION**", etc. are used.

Be sure to understand the contents of the displays before reading the text.

PICTOGRAPHS AND DEFINITIONS

 **DANGER** Indicates that mishandling the product by disregarding this pictograph will cause severe injury or death.

 **WARNING** Indicates that mishandling the product by disregarding this warning will cause a potentially hazardous situation which can result in death or serious injury.

 **CAUTION** Indicates that mishandling the product by disregarding this caution will cause a slight hazardous situation which can result in personal injury and/or material damage.

For the safe usage of the product, the following pictographs are used:



Indicates "**HANDLE WITH CARE.**" In order to protect the human body and equipment, this display is attached to places where the instruction manual should be referred to



Indicates a "**protective earth terminal.**" Before operating the equipment, be sure to connect it to the ground (this step may be omitted for products in which a power cable with earth is used)

- **Perform work in accordance with the instructions herein stated:**
Instructions for work are explained by paying attention to the aspect of accident prevention. Failing to perform work as per the instructions can cause accidents. In the case where only those who have technical expertise should perform the work to avoid hazardous situation, the instructions herein state that the site maintenance personnel should perform such work
- **Be sure to turn off the power before working on the machine:**
To prevent an electric shock, be sure to turn off the power and unplug the power cable before carrying out any work that requires direct contact with the interior of the product. If the work is to be performed in the power-on status, the instruction manual herein always states to that effect
- **Be sure to ground the earth terminal (not required in the case where a power cable with earth is used):**
This product is equipped with the earth terminal. When installing the product, connect the earth terminal to the "accurately grounded indoor earth terminal" by using an earth wire. Unless the product is grounded appropriately, the user can be subject to an electric shock. After performing repair, etc. for the control equipment, ensure that the earth wire is firmly connected to the control equipment
- **Ensure that the power supply used is equipped with an earth leakage breaker:**
Using a power supply which is not equipped with the earth leakage breaker can cause a fire when earth leakage occurs
- **Be sure to use fuses which meet the specified rating (only for the machines which use fuses):**
Using fuses that exceed the specified rating can cause a fire and an electric shock

- **Specification changes (removal of equipment, conversions and additions) not designated by SEGA are not allowed:**

The parts of the product include warning labels for safety, covers for personal protection, etc. It is very hazardous to operate the product by removing parts and/or modifying the circuits. Should doors, lids and protective parts be damaged or lost, refrain from operating the product, and contact where the product was purchased from or the office herein stated.

SEGA shall not be held responsible for any accidents or compensation for damage to a third party resulting from the specifications not designated by SEGA

- **Ensure that the product meets the requirements of appropriate electrical specifications:**

Before installing the product, check for electrical specifications. SEGA products have a nameplate on which the electrical specifications are described. Ensure that the product is compatible with the power supply voltage and frequency requirements of the location. Using any electrical specifications different from the designated specifications can cause a fire and an electric shock

- **Install and operate the product in places where appropriate lighting is available, allowing warning labels to be clearly read:**

To ensure safety for the customers, labels and printed instructions describing potentially hazardous situations are applied to places where accidents can be caused. Ensure that where the product is operated has sufficient lighting allowing the warnings to be read. If any label is peeled off, apply it again immediately. Please place an order with where the product was purchased from or the office herein stated

- **When handling the monitor, take considerable care (applies only to products with monitors):**

Some of the monitor parts are subject to high tension voltage. Even after turning off the power, some portions are still subject to high tension voltage. Monitor repair and replacement should be performed only by those technical personnel who have knowledge of electricity and technical expertise

- **Be sure to adjust the monitor properly (applies only to products with monitors):**

Do not operate the product leaving on-screen flickering or blurring as it is. Using the product with the monitor not properly adjusted may cause dizziness or a headache to an operator, a player, or customer

- **When transporting or reselling this product, be sure to attach this manual to the product**

* *In the case where commercially available monitors and printers are used in this product, only the contents relating to this product are explained herein. Some commercially available equipment has functions and reactions not stated in this Manual. Read this Manual together with the specific instruction manual of such equipment*

* *Descriptions herein contained may be subject to improvement changes without notice*

* *The contents described herein are fully prepared with due care. However, should any question arise or errors be found, please contact SEGA*

INSPECTIONS IMMEDIATELY AFTER TRANSPORTING THE PRODUCT TO THE LOCATION

Normally, at the time of shipment, SEGA products are in a status allowing for usage immediately after transporting to the location. Nevertheless, an irregular situation may occur during transportation. Before turning on the power, check the following points to ensure that the product has been transported in a satisfactory status:

- Are there any dented portions or defects (cuts, etc.) on the external surfaces of the cabinet?
- Are castors and adjusters damaged?
- Do the power supply voltage and frequency requirements meet with those of the location?
- Are all wiring connectors correctly and securely connected? Unless connected in the correct way, connector connections can not be made accurately. Do not insert connectors forcibly.
- Do power cables have cuts or dents?
- Are all accessories available?
- Can all doors and lids be opened with the accessory keys? Can doors and lids be firmly closed?

INTRODUCTION

This Manual is intended to provide detailed descriptions together with all necessary information covering the general operation of electronic assemblies, electromechanical, servicing control, spare parts, etc. for the product:

"BOP IT ARCADE"

This Manual is intended for the owners and personnel managers in charge of operation of this product. Operate the product after carefully reading and sufficiently understanding the instructions.

In the unlikely event that the product does not function correctly, **DO NOT** allow anyone other than a technician to touch the internal system. Turn off the power to the machine, making sure to unplug the electrical cord from the outlet, and contact the office listed below or the point-of-purchase for this product.

Use of this product is unlikely to cause physical injuries or damage to property. However, points that require special attention are indicated by bold text, the words "**STOP**", "**IMPORTANT**", "**WARNING**", or "**CAUTION**" and the symbols below.

IMPORTANT

Indicates important information that, if ignored, may result in the mishandling of the product and cause faulty operation or damage to the product

WARNING **CAUTION**

Indicates a warning or caution that, if ignored, may result in the mishandling of the product and cause faulty operation or damage to the product

Sega Amusements International Limited



42 Barwell Business Park, Leatherhead Road
Chessington
Surrey, KT9 2NY
United Kingdom

European Sales:	+44 (0)208 391 8090	Email:	sales@segaarcade.com
USA Sales:	+00 (1) 224 265 4287	Email:	sales@segaarcade.com
STS (Spares):	+44 (0) 208 391 8060 (Option 1)	Email:	stssales@segaarcade.com
Tech Support:	+44 (0)208 391 8060 (Option 2)	Email:	technical@segaarcade.com
Prize & Merchandise:	+44 (0)208 391 8060 (Option 1)	Email:	stssales@segaarcade.com

Web: <https://segaarcade.com/>

SPECIFICATIONS

Standard Cabinet

Machine Dimensions:	1.2m (47.2in) [Width] x 0.7m (27.5in) [Depth]
Machine Height:	2.68m (105.5in) (Installed)
Machine Weight:	166kg Approx (Installed) (366lbs)
Power, maximum current:	-220w-
Rating:	115-230VAC @ 50/60Hz
Fuse Rating:	3.15A

INDIVIDUAL SPECIFICATIONS

Main Cabinet

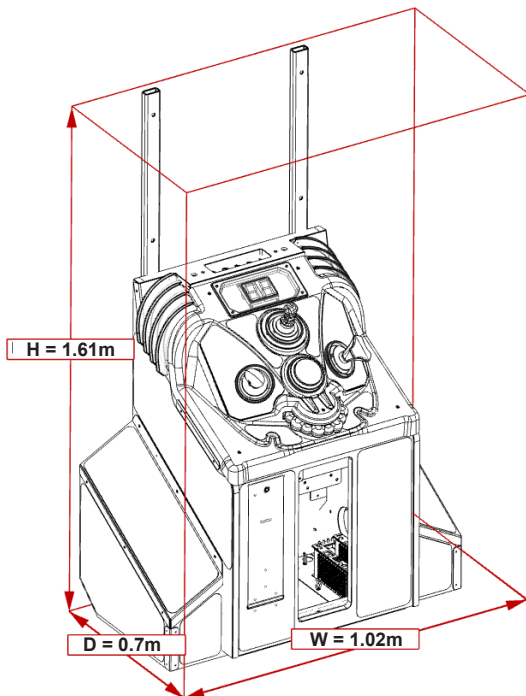

Main Display

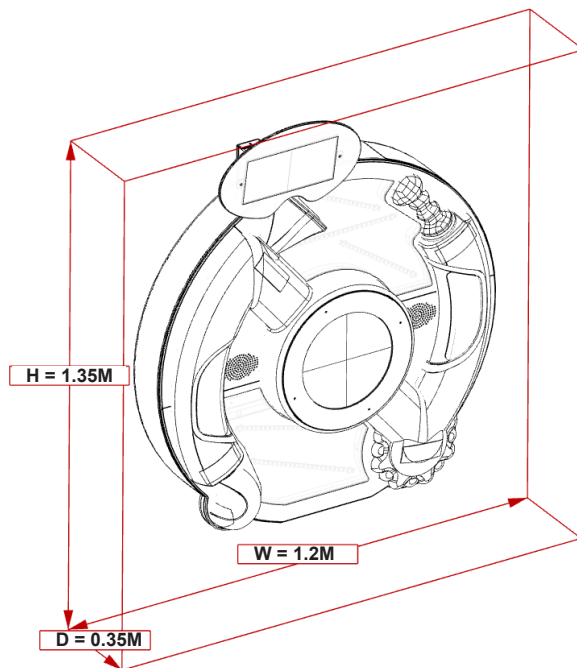

Billboard

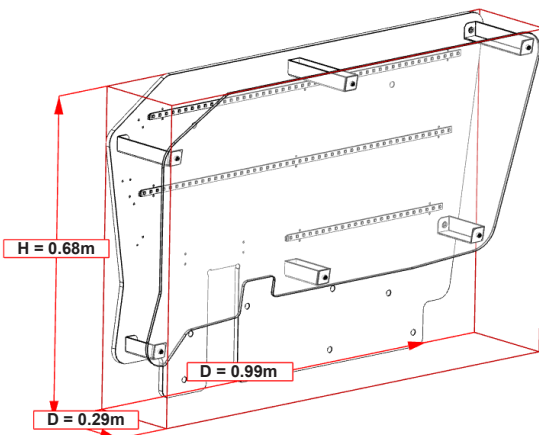

Definition of 'Site Maintenance Personnel' or Other Qualified Individuals

IMPORTANT

Procedures not described in this Manual or marked as 'to be carried out by Site Maintenance Personnel or other qualified professionals' should not be carried out by personnel without the necessary skill or technological experience. Work carried out by unqualified persons may cause serious accidents, including electrocution

Parts replacement, maintenance inspections, and troubleshooting should be carried out by site maintenance personnel or other qualified professionals. This Manual includes directions for potentially dangerous procedures which should only be carried out by professionals with the appropriate specialised knowledge.

The site maintenance personnel or other qualified professionals mentioned in this Manual are defined as follows:

Site Maintenance Personnel:

Individuals with experience in maintaining amusement equipment, vending machines, etc., working under the supervision of the owner/operator of this product to maintain machines within amusement facilities or similar premises by carrying out everyday procedures such as assembly, maintenance inspections, and replacement of units/expendable parts.

Activities to be carried out by Site Maintenance Personnel:

Amusement equipment/vending machine assembly, maintenance inspection and replacement of units/expendable parts.

Other qualified professionals:

Persons employed by amusement equipment manufacturers, or involved in design, production, testing or maintenance of amusement equipment. The individual should have either graduated from technical school or hold similar qualifications in electrical/electronics/mechanical engineering.

Activities to be carried out by other qualified professionals:

Amusement equipment/vending machine assembly, repair/adjustment of electrical/electronic/mechanical parts.

Waste of Electrical and Electronic Equipment (WEEE) Statement

The WEEE (Waste of Electrical and Electronic Equipment) directive places an obligation on all EU based manufacturers and importers of Electrical and Electronic Equipment (EEE) to ensure waste equipment is disposed of in accordance with the directive at the end of their useful life.

The symbol shown below will be placed on all products manufactured from 13th August 2005, which indicates this product must NOT be disposed of with other normal waste.

Upon purchasing any EEE from SEGA Amusements International Ltd., the user accepts responsibility to dispose of their waste equipment by arranging to return it to a designated UK collection point (AATF) or an Approved Exporter (AE) for the correct recycling of waste electrical and electronic equipment.

For more information on Approved Authorised Treatment Facilities (AATF) within the UK please consult the government website: www.gov.uk/weee

For users outside of the UK, EEE should be disposed of in accordance with the local policy on the recycling of Waste Electrical and Electronic Equipment.

Battery Recycling Statement

The EC Directive on Batteries and Accumulators (2006/66/EC) aims to minimise the impact of batteries on the environment and encourage the recovery of the materials they contain. To achieve increased collection and recycling of waste batteries, the Directive places 'producer responsibility' obligations on manufacturers and importers of portable, industrial and automotive batteries.

The symbol shown below will be on all equipment fitted with batteries from 26th September 2008 and indicates they must NOT be disposed of with other normal waste. Instead, it is the user's responsibility to dispose of used batteries by arranging to return them to a designated collection point for the correct recycling.

For more information about where you can send your waste batteries for recycling contact your local authority office.



READ BEFORE OPERATING

OPERATOR NOTICE OF LEGAL REQUIREMENTS

This game is a ticket redemption game. The laws and regulations on operating ticket redemption games are different in individual states, countries and territories.

The game has settings and operator options to accommodate various levels of skill and ticket payout. Local laws, regulations and codes can impact the stake, value of ticket payout and the level of skill required to win.

Not all settings and options are suitable for every jurisdiction. In some jurisdictions, ticket redemption games are prohibited.

IT IS SOLELY YOUR RESPONSIBILITY AS THE OPERATOR OF THE GAME TO:

- fully comply with laws, regulations and ticket payout value limitations in the jurisdiction where you place and offer this game to the public. (Contact your legal adviser for local advice);
- ensure that the amount of ticket payout comply with local laws (in type and value); and
- use the settings and options for play to ensure the game is operated within the local laws.

Neither the manufacturer nor distributor is responsible for any failure to operate the game in accordance with the relevant laws and regulations and has no liability for any consequences of such failure.

TABLE OF CONTENTS

	INTRODUCTION	iii
1	HANDLING PRECAUTIONS	1
2	PRECAUTIONS REGARDING INSTALLATION	5
3	PRECAUTIONS REGARDING OPERATION	8
	3-1 Before Operation	8
	3-2 Paying Attention to Customers	10
4	PARTS DESCRIPTION	12
5	ACCESSORIES	13
6	ASSEMBLY AND INSTALLATION	14
	6-1 Unpacking the Cabinet	16
	6-2 Installing the Main Display	17
	6-3 Installing the Billboard	21
	6-4 Fixation to Site	23
	6-5 Confirmation of Installation	26
	6-6 Components that Change State	27
	6-7 Replacing Tickets	28
7	PRECAUTIONS WHEN MOVING	29
	7-1 Moving the Machine	29
8	GAME DESCRIPTION	31
	8-1 Game Outline	31
	8-2 Game Flow	31
9	TEST AND SERVICE DATA	33
	9-1 Switch and Coin Meter	34
	9-2 Game Test Mode	35
	9-3 Game Settings	35
	9-4 Bookkeeping	41
	9-5 System Info	44
	9-6 Lighting Test	45
	9-7 Display Test	45
	9-8 Input Test	47
	9-9 Output Test	47
	9-10 Audio Settings	48
	9-11 Date/Time	49
10	CONTROLLER UNIT	51
	10-1 Replacing the Control Units	52

11	COIN HANDLING	57
	11-1 Cleaning the Coin Selector	57
	11-2 Fault Finding	60
	11-3 Adjusting the Price of Play (Excel)	61
	11-4 Coin Region & Price of Play Settings	62
	11-5 Price of Play Quick Start (USA)	64
12	LAMPS AND LIGHTING	65
	12-1 Coin Door Lamp	65
	12-2 Cabinet LED List	66
	12-3 LED Diagrams	67
13	PERIODIC INSPECTION	72
14	TROUBLE SHOOTING	74
	14-1 Troubleshooting (No Error Message)	74
15	GAME BOARD	76
	15-1 How to Remove Game Board	77
	15-2 Game Board Location & Removal	78
	15-3 Game Board Introduction	79
	15-4 Game Board Parts Detail	80
	15-5 Replacing the Battery Button	87
	15-6 DIP Switch Settings	88
16	DESIGN RELATED PARTS	89
17	PARTS LIST	90
18	COLOUR CODE	121
19	SCHEMATIC DIAGRAM	122

1 HANDLING PRECAUTIONS

When installing or inspecting the machine, be mindful of the following points and pay attention to ensure that the player can enjoy the game safely.

Noncompliance with the following points or inappropriate handling running counter to the cautionary matters herein stated can cause personal injury or damage to the machine.

WARNING

- Before performing work, be sure to turn the power off. Performing the work without turning the power off can cause an electric shock or short circuit. In cases where work should be performed in the status of power on, this Manual always states to that effect
- To avoid an electric shock or short circuit, do not plug in or unplug quickly
- To avoid an electric shock, do not plug in or unplug with a wet hand
- Do not expose power cords or earth wires on the surface, (floor, passage, etc). If exposed, the power cords and earth wires are susceptible to damage. Damaged cords and wires can cause an electric shock or short circuit
- To avoid causing a fire or an electric shock, do not put things on or damage the power cords
- During or after installing the product, do not unnecessarily pull the power cord. If damaged, the power cord can cause a fire or an electric shock
- In the case that the power cord is damaged, ask for a replacement through where the product was purchased from or the office herein stated. Using the cord as is damaged can cause fire, an electric shock or leakage
- Be sure to perform grounding appropriately. Inappropriate grounding can cause an electric shock
- Be sure to use fuses meeting the specified rating. Using fuses exceeding the specified rating can cause a fire or an electric shock
- Be sure that connections such as IC Board are made properly. Insufficient insertion can cause an electric shock
- Specification changes, removal of equipment, conversion and/or addition, not designated by SEGA are not permitted
- Failure to observe this may cause a fire or an electric shock. Noncompliance with this instruction can have a bad influence upon the physical conditions of players or onlookers, or result in injury during play
- SEGA shall not be held responsible for damage or compensation for damage to a third party caused by specification changes not designated by SEGA
- Do not perform any work or change parts not listed in this Manual. Doing so may lead to an accident
- If you need to perform any work not listed in this Manual, request work from the office indicated in this manual or the point of purchase, or inquires for details. Be sure to perform periodic maintenance inspections herein stated

 **WARNING**

- Do not touch undesignated places. Touching places not designated can cause electric shock or short circuit
- Whenever any fasteners (e.g. screws, nuts) have been lost, be sure to use replacement fasteners with proper dimensions as specified in this Manual. If fasteners of any other dimensions are used, it could cause damage and/or separation of parts that result in secondary accidents
- Specification changes, removal of equipment, conversion and/or addition, not designated by SEGA are not permitted
- Failure to observe this may cause a fire or an electric shock. Noncompliance with this instruction can have a bad influence upon the physical conditions of players and onlookers, or result in injury during play
- SEGA shall not be held responsible for damage or compensation for damage to a third party caused by specification changes not designated by SEGA
- Performing work or parts replacements not described in this Manual could result in accidents. If you need to perform any work not listed in this Manual, request work from the office indicated in this Manual or the point-of-purchase, or inquires for details
- Be sure to perform periodic maintenance inspections herein stated

 STOP**IMPORTANT**

- For the IC board circuit inspections, only the use of a logic tester is recommended. Using a Multi-Tester or General Purpose Tester may result in damage to IC Circuits
- Static electricity from your body may damage some electronic devices on the IC board. Before handling the IC board, touch a grounded metallic surface so that the static electricity can be discharged
- Some parts are not designed or manufactured specifically for this game machine. The manufacturers may discontinue or change the specifications of such general-purpose parts. If this is the case, SEGA cannot repair or replace a failed game machine whether or not a warranty period has expired

CONCERNING THE STICKER DISPLAY

This SEGA product has stickers attached describing the product manufacture No. (Serial No.) and Electrical Specifications. It also has a Sticker describing where to contact for repair and for purchasing parts.

When inquiring about or asking for repairs, **mention the Serial No. and Name of Machine indicated on the Sticker.**

The Serial Number indicates the product register. Identical machines could have different parts depending on the date of production. Also, improvements and modifications might have been made after the publication of this Manual.

In order to ensure you order the correct parts, mention the Serial No. when contacting the applicable places.

CONCERNING WARNING DISPLAYS

This SEGA product has warning displays on stickers, labels and/or printed instructions adhered/attached to or incorporated in the places where a potentially hazardous situation could arise. The warning displays are intended for accident prevention for customers and for avoiding hazardous situations relating to maintenance and servicing work.

Some portions of the Cabinet contain high voltage and may cause accidents if touched. When performing maintenance, be very careful of the warning displays. It is especially important that any complex repair and replacement work not mentioned herein should be performed by those technical personnel who have knowledge of electricity and has technical expertise.

In order to prevent accidents, caution any customer ignoring the warnings to cease and desist immediately.

1 HANDLING PRECAUTIONS

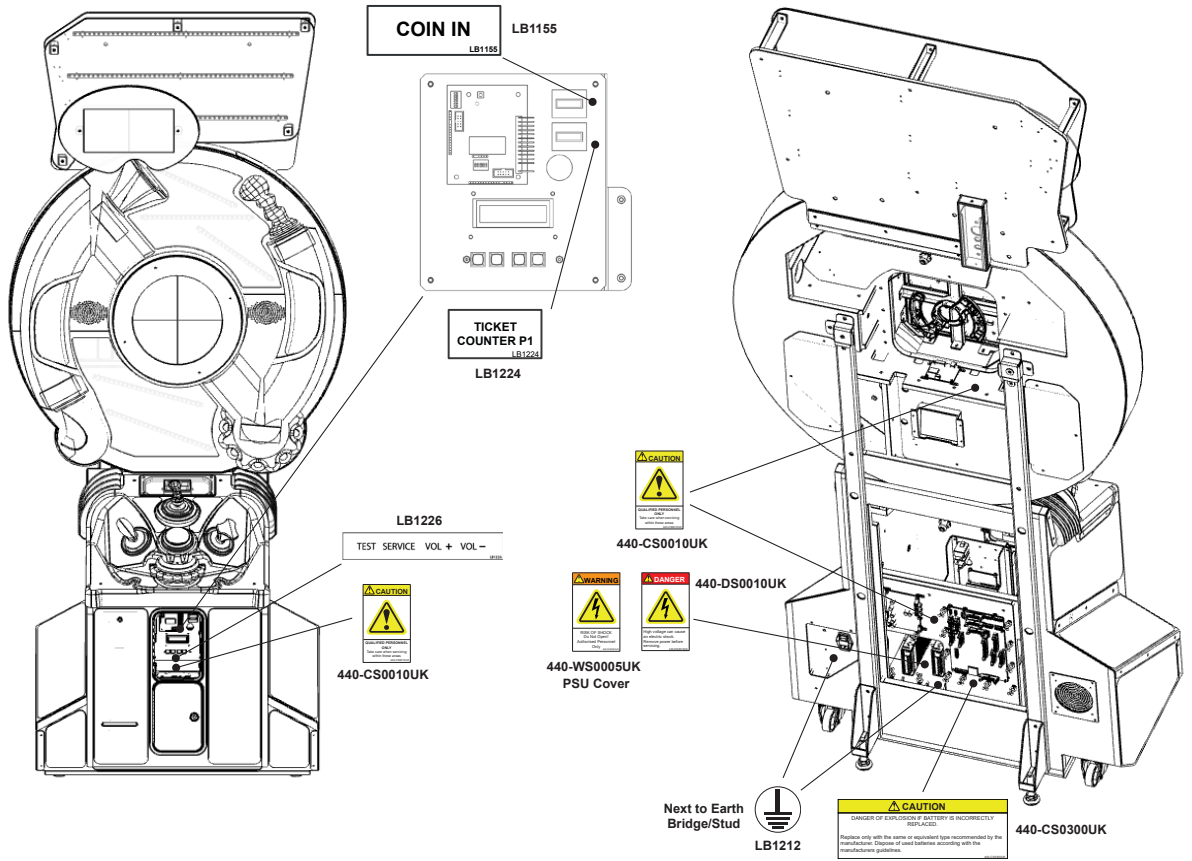
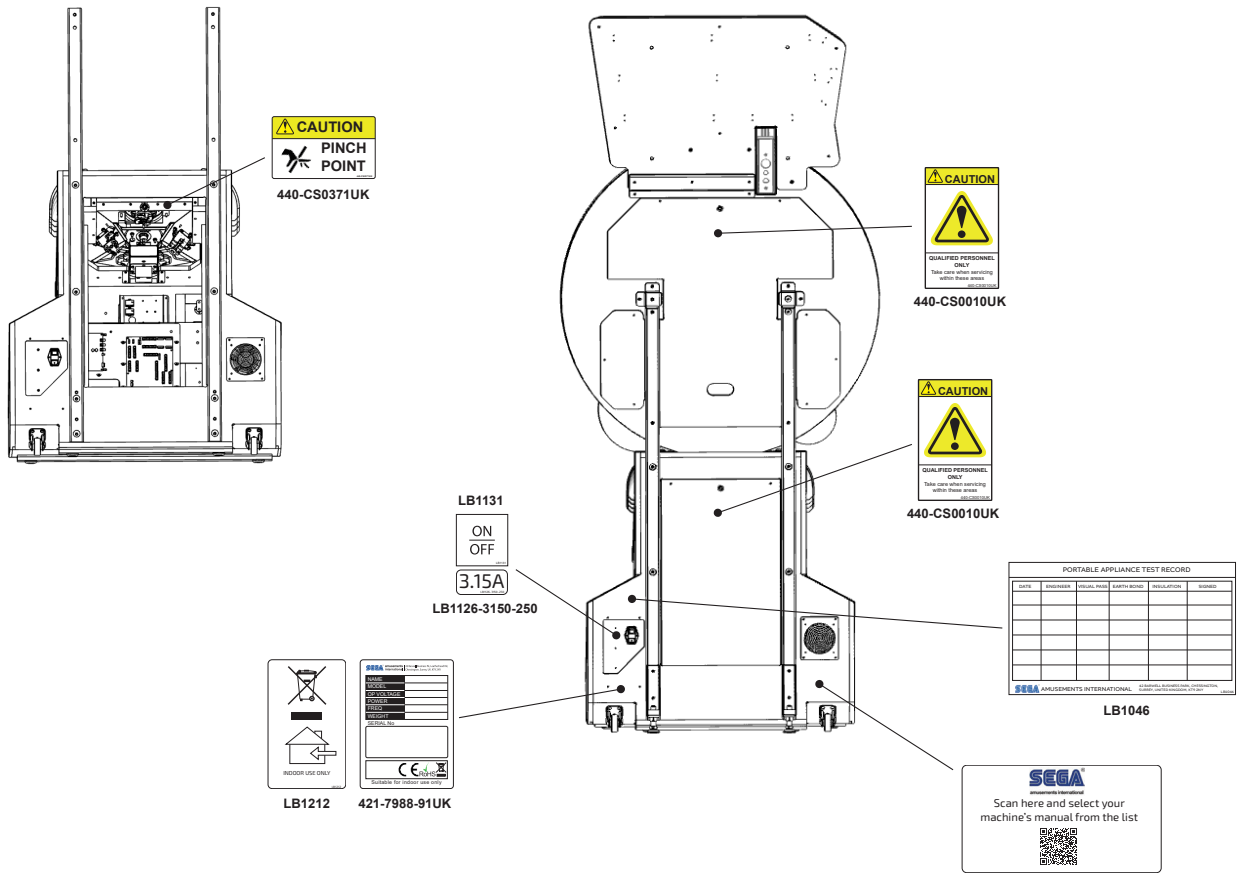

2 PRECAUTIONS REGARDING INSTALLATION

WARNING

- This product is an indoor game machine. Do not install it outside. Even indoors, avoid installing in places mentioned below so as not to cause fire, electric shock, injury and/or malfunction:
- Places subject to rain/water leakage or places subject to high humidity, in the proximity of an indoor swimming pool and/or shower, etc
- Places subject to direct sunlight or places subject to high temperatures, in the proximity of heating units, etc
- Places filled with inflammable gas or vicinity of highly inflammable/volatile chemicals or hazardous matter
- In dusty places or locations prone to heavy dust accumulation
- On sloped or uneven surfaces
- Places subject to any type of violent impact
- Vicinity of anti-disaster facilities such as fire exits and fire extinguishers
- Areas where the temperature exceeds the applicable temperature (ambient temperature) range of 5 to 30 degrees centigrade

2-1 LIMITATIONS OF USAGE

WARNING

- Be sure to check the Electrical Specifications. Ensure that this product is compatible with the location's power supply, voltage, and frequency requirements. A plate describing Electrical Specifications is attached to the product. Noncompliance with the Electrical Specifications can cause a fire and electric shock
- This product requires a Breaker and Earth Mechanism as part of the location facilities. Using the product without these can cause a fire and electric shock
- Ensure that the indoor wiring for the power supply is rated at 15 A or higher (AC single phase 100 V ~ 120 V area), and 7 A or higher (AC 220 V ~ 240 V area). Noncompliance with the Electrical Specifications can cause a fire and electric shock
- Be sure to use an independent power supply equipped with an Earth Leakage Breaker. Using a power supply without an Earth Leakage Breaker can cause an outbreak of fire if a power surge occurs
- Putting many loads on one electrical outlet can cause generation of heat and a fire resulting from overload
- When using an extension cord, ensure that the cord is rated at 15 A or higher (AC 100 V ~ 120 V area) and 7 A or higher (AC 220 V ~ 240 V area). Using a cord rated lower than the specified rating can cause a fire and electric shock

STOP IMPORTANT

- Securing a safe area for operation as described in this Manual will ensure safe operation for players and observers
- SEGA shall not be held responsible for damage or compensation for damage to a third party, resulting from the failure to observe this instruction

2-2 OPERATION AREA** WARNING**

- For safe operation, use and operate this product in an area measuring at least 1.84m (72.4in) in width and 1.28m (50.3in) in depth when the Cabinet is installed. SEGA shall not be held responsible for damage or compensation for damage to a third party, resulting from the failure to observe this instruction
- The ceiling where this product is installed must be at least 2.7m (106.3in) high. If the ceiling is too low, the heat emitted from the product may cause it to catch on fire
- Be sure to provide the sufficient space specified in this Manual. Do not allow objects to block the ventilation ports. This can cause generation of heat and a fire
- Put the Cabinets close together so that people cannot get through or provide enough space between them that people can go both ways without difficulty. If the Cabinets are installed carelessly, people may bump into each other or the Cabinets when passing between them or fall down. To prevent people from walking between them, place them 0.15 m (5.9 in) apart
- If the machine does not fit through the entryway to the installation location, do not disassemble it without first consulting the instructions. Specific tools and adjustment procedures are required to assemble and disassemble the mechanical parts
- Attempting to assemble or disassemble the machine without consulting the instructions may result in accidents during assembly/disassembly, electric shock, short circuits, and/or personal injury during operation. If the machine still does not fit through the entryway after following the procedures in this Manual, contact your retailer or the office listed in this Manual
- If the machine is still too large to fit through the entryway after following the procedures listed in this Manual, do not tip the machine on its side. Attempting to transport the machine while it is tipped on its side may cause accidents. It may also damage or warp parts of the machine, resulting in accidents during operation

⚠ WARNING

- To install this product, the entrance must be at least 0.7m (27.5in) in width and 2.44m (96.1in) in height without Assy Billboard and 2.68m (105.5in) with Assy Billboard
- If the entrance is too narrow, do not tilt the product carelessly. If all the product weight is put on the castors at one side only, there could be damage or deformation, causing serious accidents such as workers getting caught underneath

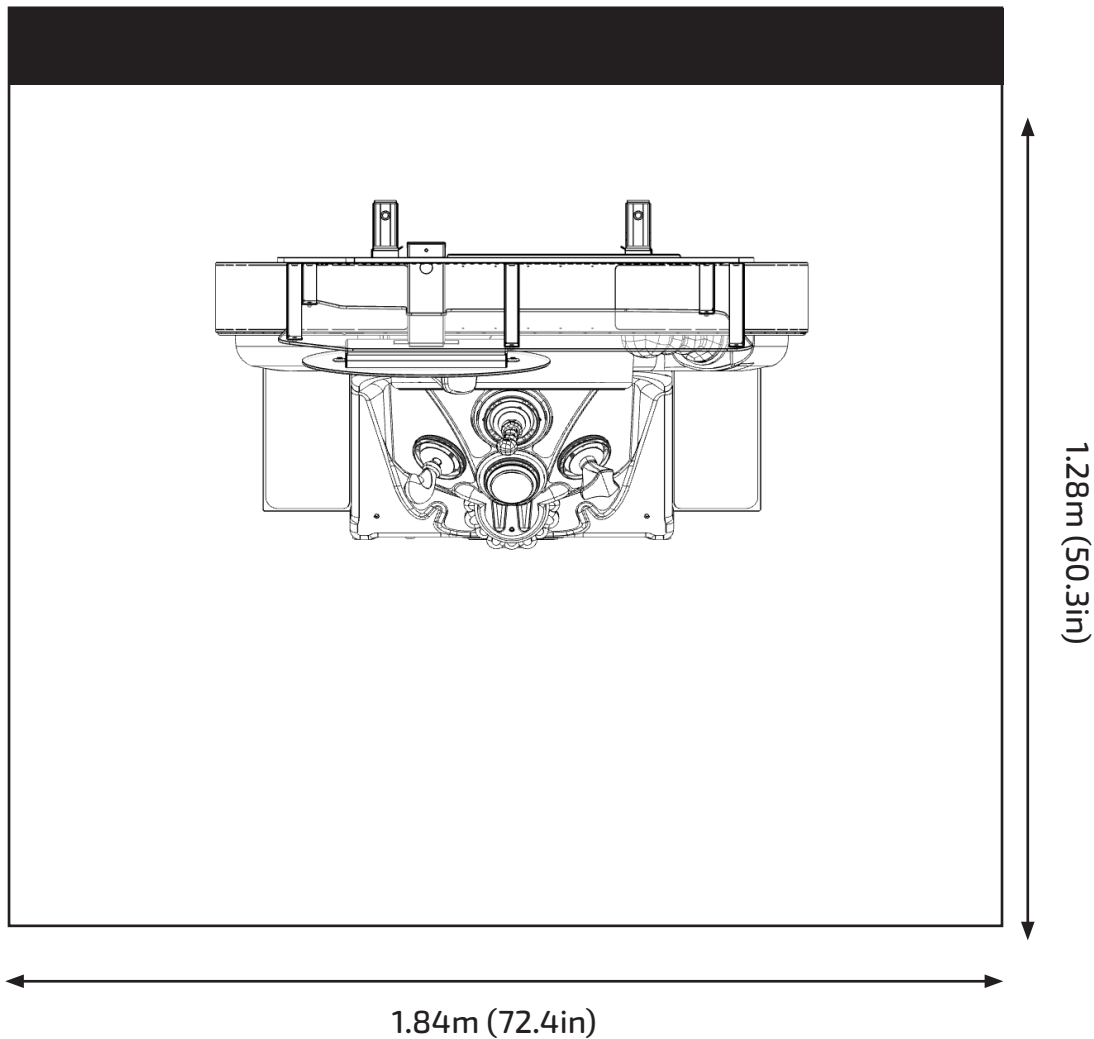

3 PRECAUTIONS REGARDING OPERATION

To avoid injury and trouble, be sure to pay attention to the behaviour of visitors and players.

3-1 BEFORE OPERATION

WARNING

- In order to avoid accidents, check the following before starting the operation:
- To ensure maximum safety for the players and the customers, ensure that where the product is operated has sufficient lighting to allow any warnings to be read. Operation under insufficient lighting can cause bodily contact with each other, hitting accident, and/or trouble between customers
- It is suggested to ensure a space allowing the players who feel sick while playing the game to take a rest
- Check if all of the adjusters are in contact with the surface. If they are not, the Cabinet can move and cause an accident
- Do not put any heavy item on this product. Placing any heavy item on the product can cause a falling down accident or parts damage
- Do not climb on the product. Climbing on the product can cause falling down accidents. To check the top portion of the product, use a step/stepladder
- To avoid electric shock, check to see if door and cover parts are damaged or omitted
- Do not place the following items on top of or near the product or hang them from the ceiling. Doing so could result in electric shock, short circuits and/or damage to the parts:
- Flower vases, flowerpots, cups, water tanks, cosmetics, and receptacles/containers/vessels containing chemicals and water

CAUTION

- To avoid injury, be sure to provide sufficient space by considering the potentially crowded situation at the installation location. Insufficient installation space can cause contact, collisions, and/or trouble between customers
- During daily cleaning, be sure to check the surface of the Control Unit and other parts that the player touches with his/her hands for damage, cracks, or loose screws. If a player uses the machine while it is damaged, cracked, or has a loose screw, the player may become injured
- Check carefully to make sure there are no gaps in the Cabinet joints and that they are not loose. If there are gaps or looseness, players may get their hands or fingers caught, resulting in an injury
- Make sure all the doors are locked securely and they do not rattle. If the doors are not locked properly or there are gaps or rattling, players could get their fingers or hands caught
- Inspect for the following items during a trial run. If there is any type of error, use the Test Mode, etc. to resolve the problem. If you continue use with an error, it can cause an accident or irreparable parts damage:
 - Is there any strangeness in the operability of the Control Unit?
- Prepare a place where players can rest if they feel sick

3-2 PAYING ATTENTION TO CUSTOMERS

To avoid injury and trouble, be sure to constantly give careful attention to the behaviour and manner of the visitors and players.

DURING OPERATION (PAYING ATTENTION TO CUSTOMERS)

WARNING

- For safety reasons, do not allow any of the following people to play the game:
 - Those who have high blood pressure or a heart problem
 - Those who have experienced muscle convulsion or loss of consciousness when playing video games, etc
 - Those who have neck or spinal cord problems
 - Those who are intoxicated or under the influence of drugs
 - Pregnant women
 - Those who are not in good health
 - Those who do not follow the attendant's instructions
 - Those who cannot grasp the Control Unit securely because of immobility in fingers, hands or arms
 - Persons who disregard the product's warning displays
- Even players who have never been adversely affected by light stimulus might experience dizziness or headache depending on their physical condition when playing the game
- Small children are especially likely to experience these symptoms. Caution guardians of small children to keep watch over them during play
- Instruct those who feel sick during play to have a medical examination
- To avoid injury from falls and electric shocks due to spilled drinks, instruct the player not to place heavy items or drinks on the product
- To avoid electric shocks and short circuits, do not allow customers to put hands, fingers or extraneous matter in the openings of the product or small openings in and around the doors
- To avoid falls and resulting injury, immediately stop the customer from leaning against or climbing on the product, etc
- To avoid electric shock and short circuit, do not allow customers to unplug the power plug without a justifiable reason
- Instruct the guardians of small children to keep watch over their children
- Children cannot sense danger. Allowing small children to get near a player who is playing the game could result in the children being bumped, struck or knocked down

STOP IMPORTANT

- Diligently clean the parts that players touch directly to ensure a pleasant game playing experience
- Inspect the coin insertion slots to make sure no foreign objects have been inserted and that they have not otherwise been tampered with as this will prevent play

CAUTION

- Immediately stop such violent acts as hitting and kicking the product. Such violent acts can cause parts damage or falling down, resulting in injury due to fragments and falling down
- Persons other than the player should not be allowed to touch the controls during play. They may brush against or collide with the controls or the player, possibly resulting in accidents
- Instruct those who feel sick during play to have a medical examination
- Immediately stop users from leaning or sitting on the Control Panel. Such acts can lead to injury or damage to parts or the shape of the Cabinet
- Items such as large finger rings can cause injury to the fingers while playing. Instruct players to remove all accessories that could cause an accident before playing

4 PART DESCRIPTIONS

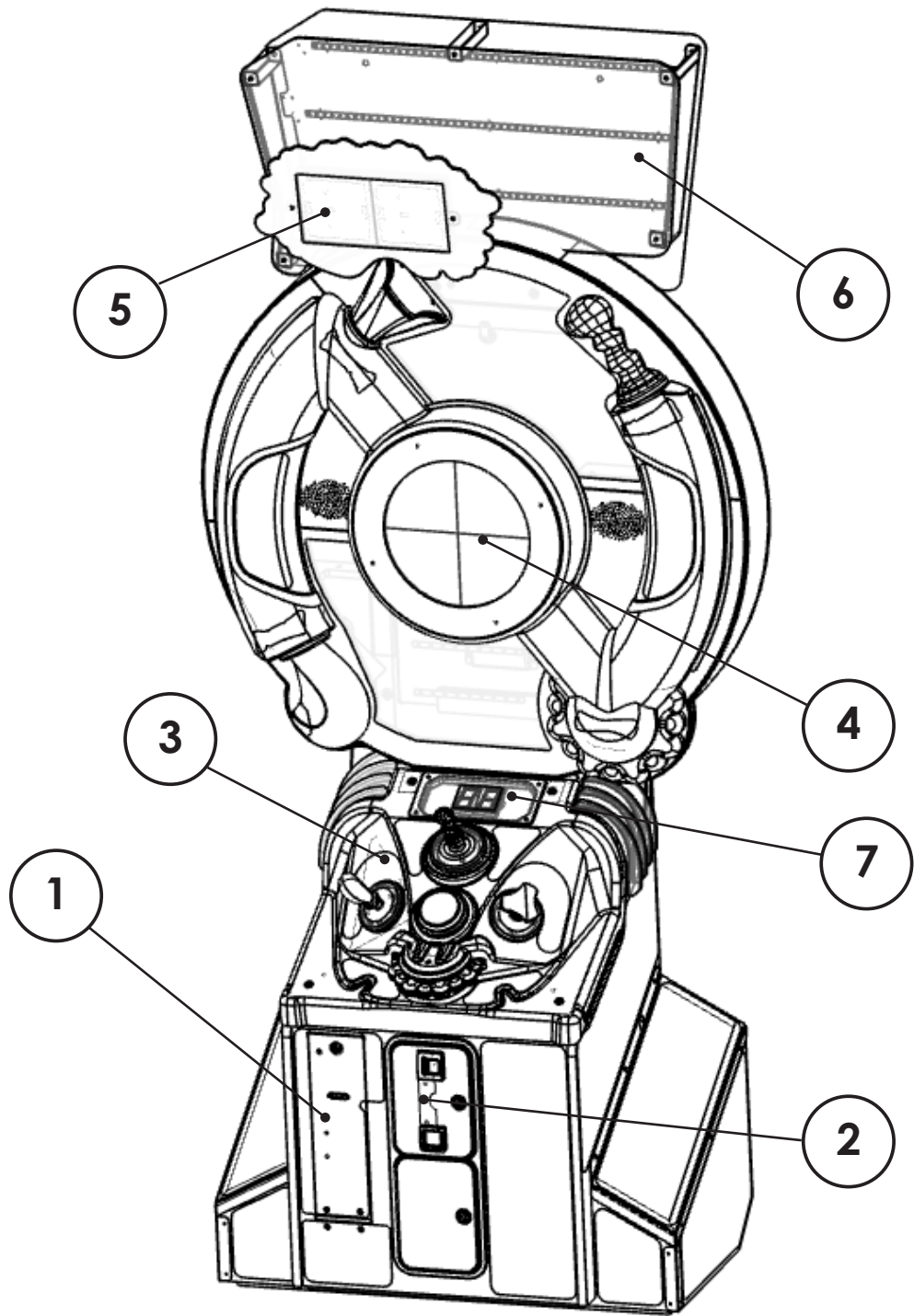

1	Ticket Door
2	Coin Door
3	Control Panel + Control Units
4	LED Game Display
5	LED Billboard Display
6	Billboard
7	Score Count

5 ACCESSORIES

Confirm that the accessories listed in the table below are present when setting up the product.
Accessories marked “Spare” are consumable items but included as spares.

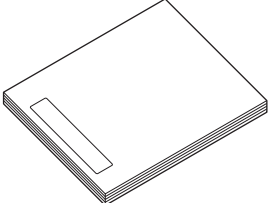
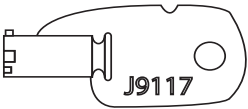
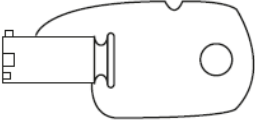
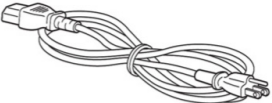
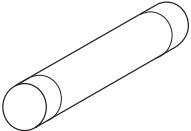
Part Name / Number	Diagram	Quantity
Owner's Manual (Part #: 420-0040UK)		1
Master Key (J9117)		4
Security Key (A444)		2
Power Lead UK (Pt No LM1227) EU (Pt No LM1246) US (Pt No LM1500UK)		1ea
Spare Fuse (Fitted to ASSY AC UNIT)		1

6 ASSEMBLY AND INSTALLATION

⚠ WARNING

- Perform assembly work by following the procedure herein stated. Failure to comply with the instructions can cause electric shock
- Perform assembling as per this Manual. Since this is a complex machine, incorrect assembling can cause an electric shock, machine damage and/or improper functioning as per specified performance
- When assembling, more than one person is required. Depending on the assembly work, there are some cases in which working by one person alone can cause personal injury or parts damage
- Ensure that connectors are properly connected. Improper connections can cause electric shock
- Be careful not to damage the wires. Damaged wires may cause electric shock or short circuit or present a risk of fire
- This work should be carried out by site maintenance personnel or other qualified professionals. Work performed by non-technical personnel can cause a severe accident such as electric shock. Failing to comply with this instruction can cause a severe accident such as electric shock to the player during operation. If no one with proper technological expertise is available, request service from the office indicated in this document or the point of purchase so as to ensure safety
- Provide sufficient space so that assembling can be performed. Performing work in places with narrow space or low ceiling may cause an accident and assembly work to be difficult
- To perform work safely and avoid serious accident such as the Cabinet falling down, do not perform work in places where step-like grade differences, a ditch, or slope exist
- Do not leave power cords or Ground Wires exposed in areas of heavy foot traffic. Doing so may cause them to become damaged, possibly resulting in electric shock and/or short circuits. When laying wiring across the floor, always use safety covers to protect the wires. (Wiring diameter: power cable - approx. \varnothing 8)
- Have a flashlight or another supplementary lighting unit available while working. With indoor lighting alone, the Cabinet interior may be too dark. Working without proper lighting can lead to accidents. It also hinders proper work performance
- The Cabinet has ventilation ports. Be sure not to block them. If they are blocked, heat can build up, leading to fire. This can also accelerate wearing of parts and malfunctions
- Secure ample ventilation space around the Cabinet. If heat builds up, there could be accidents associated with heat or smoke generation
- This product does not use any connectors other than those connected to and used by the Game Board when it leaves the factory. Do not needlessly connect wires to unused connectors. This could lead to overheating, generation of smoke and burn related injuries

CAUTION

- Handle molded parts with care. Excessive weight or pressure may cause them to break and the broken pieces may cause injury
- To perform the operation safely and accurately you must use a safe, steady footstool or stepladder. Working without this may lead to a fall and possible injury
- When attaching or removing doors or lids, be careful that your hand or finger does not get caught in anything

IMPORTANT

- Be careful not to damage parts surfaces. In some cases, if such surfaces are damaged, the part must be replaced; it cannot be reinforced or repaired
- Ensure to carry out the installation with a minimum of 2 people

6-1 UNPACKING THE CABINET

1 Remove top packaging cover and pallet sleeve



2 Remove securing strap and bar strap board

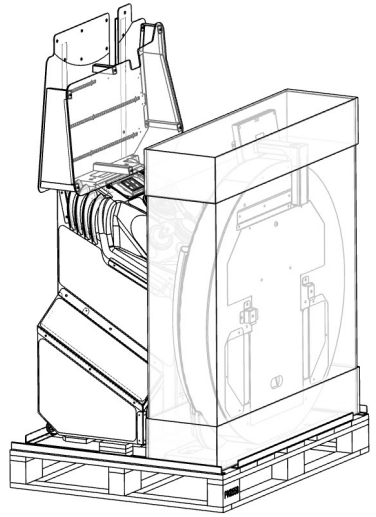
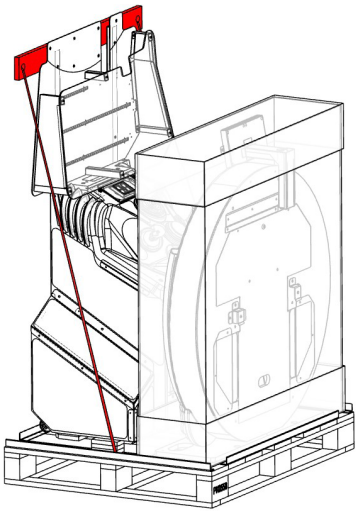

6-2 INSTALLING MAIN DISPLAY

- 1 Remove the Billboard from the Main Cabinet by removing the (4) securing fixings and set the Billboard to one side

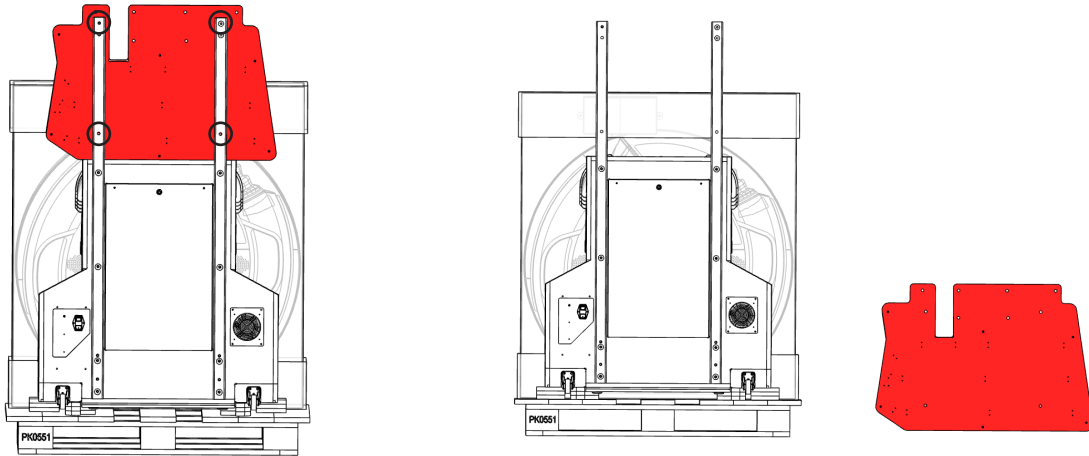

- 2 Remove the top packaging from the Display Cab sleeve (**IMPORTANT - DO NOT attempt to move the Display Cabinet in or from the outer box before properly removing all packaging as this could irreperably damage the Display Cabinet**)

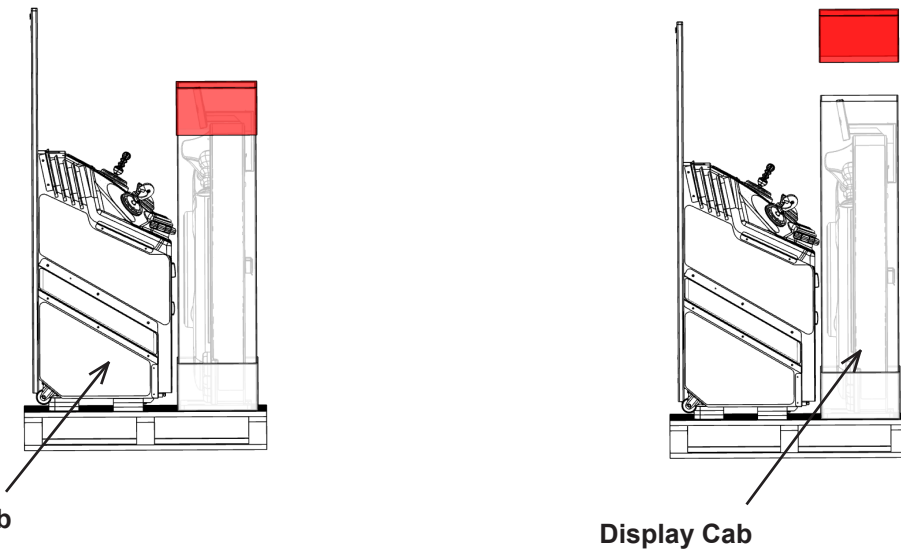

- 3 Remove the main packaging sleeve (remove the Bonus Box Artwork from the packaging and set aside with the Billboard)

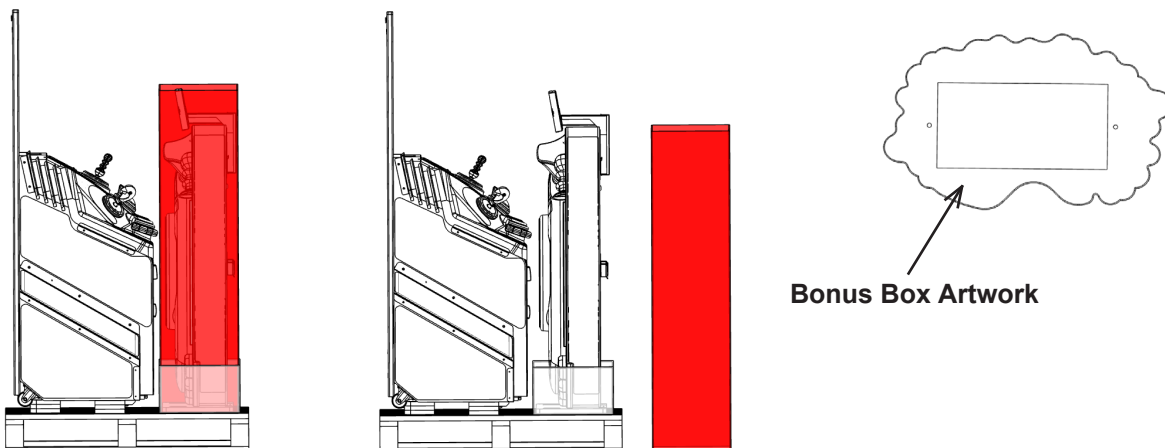

- 4 Remove the (3) transit fixings of the Display Cabinet that secure the Transit Board to the pallet

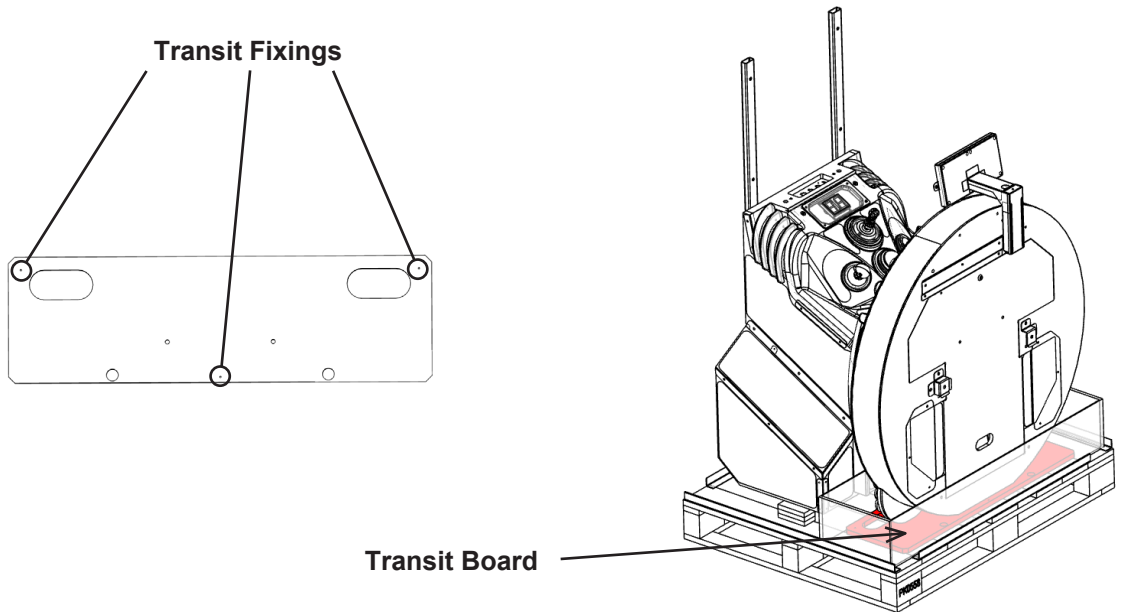

- 5 Remove the Door Box Display Back by removing the (2) fixings and unlocking with the supplied key

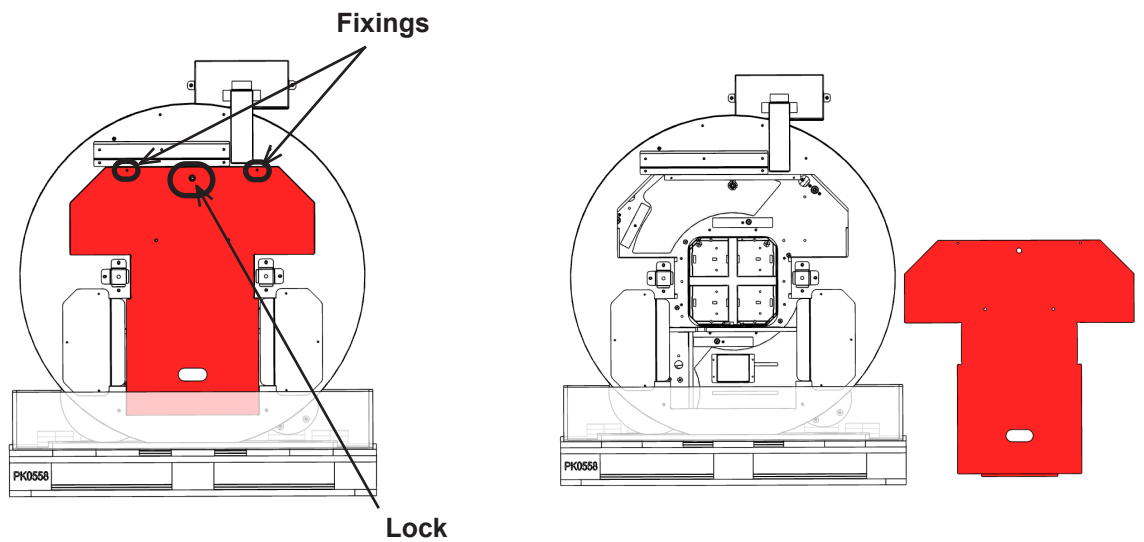

- 6 Remove the Display Cabinet from the pallet. Remove the Main Cabinet from the pallet and place into position behind the Display Cabinet with the front of the Cabinet facing towards the Display Cabinet

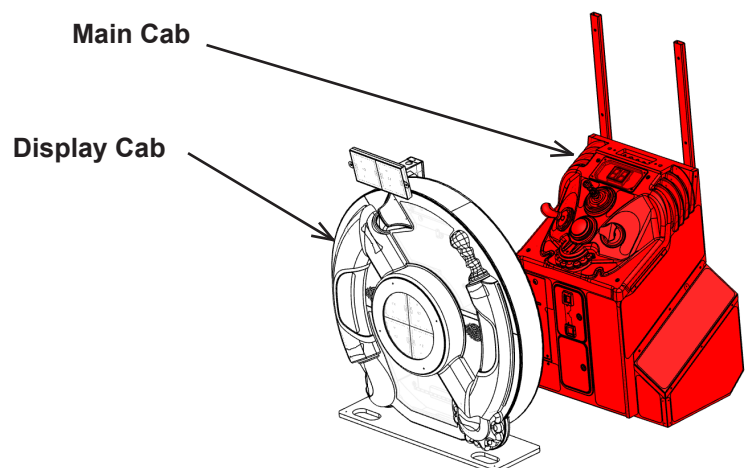

7 Apply the (2) Stabilizer Backs into position at the Rear Base of the Main Cabinet (note: adjust Stabilizer Feet to be in contact with the floor)

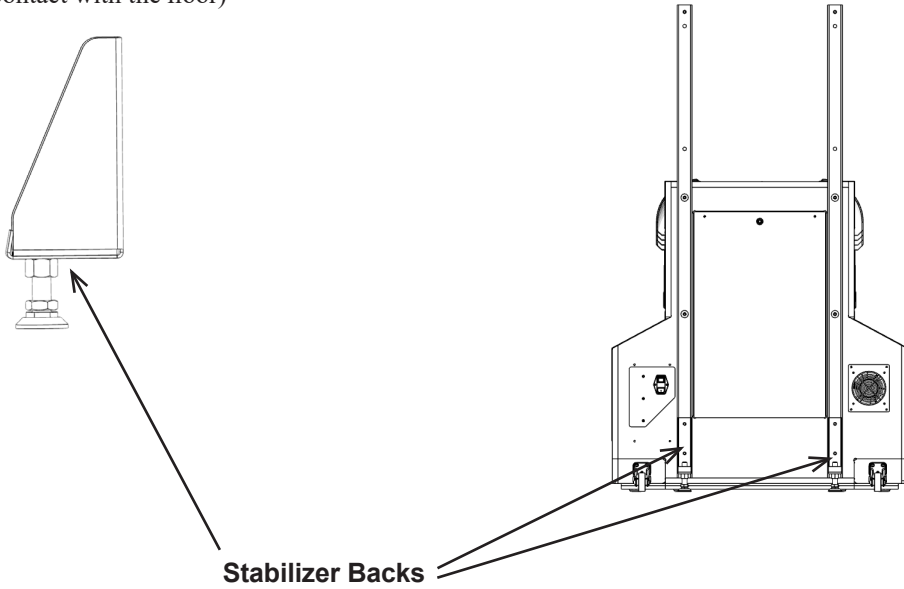

8 Remove the (2) Bolts securing the Display Cabinet to the Transit Board. Remove the bolt from each of the transit brackets securing the Display Cab (**IMPORTANT - take care when removing the bolts as the Display Cabinet can potentially move freely due to its shape**). Retain the transit board for future transit use (the transit board can be applied to the rear of the Cabinet using the 2 transit bolts)

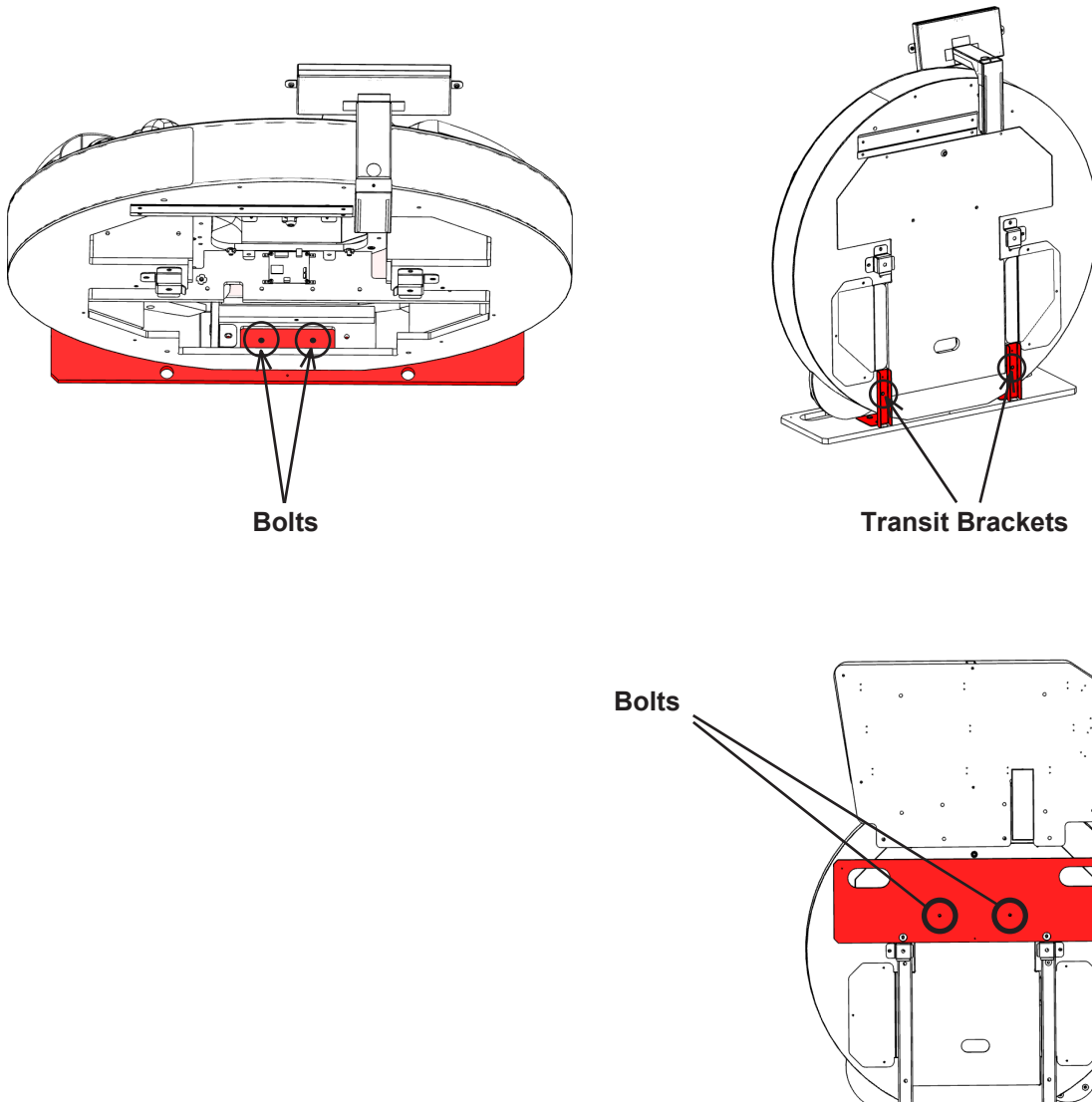

9 Using at least 2 people, raise and place the Display Cab into position over the Strut Display Support Brackets (raise Display Cab using grab points to lift). Secure the (3) fixings on each bracket to secure the Display Cab into position

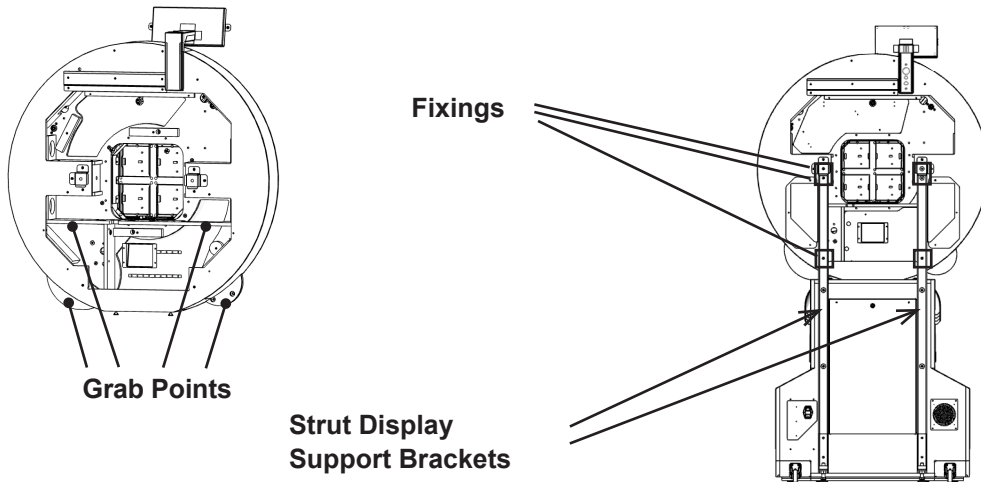

10 Connect the Harness to the Panel Mount Connectors. Secure the Display Cabinet by applying the (2) fixings highlighted

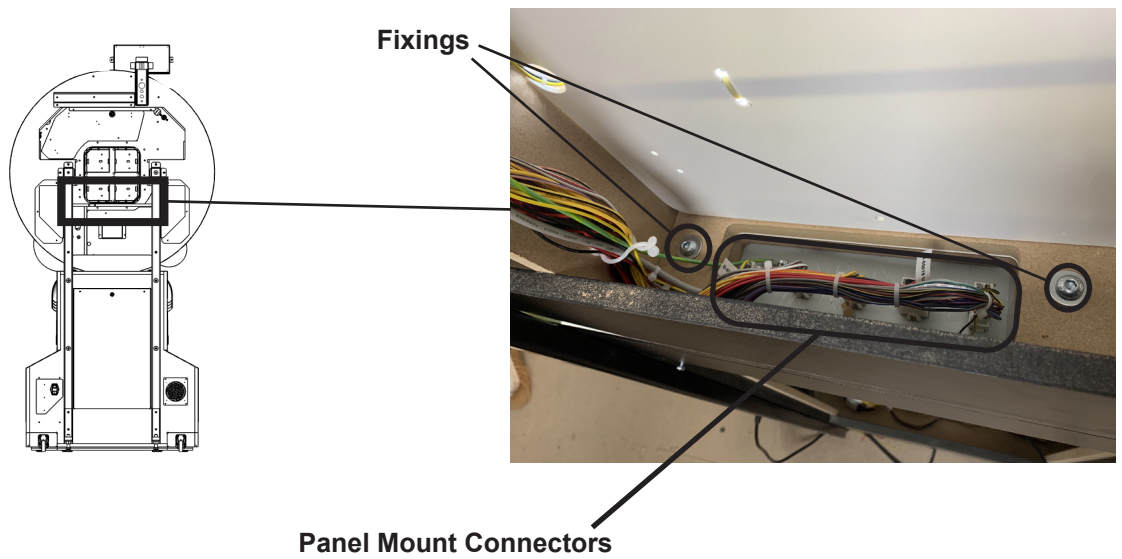

11 Reapply the Door Box Display Back

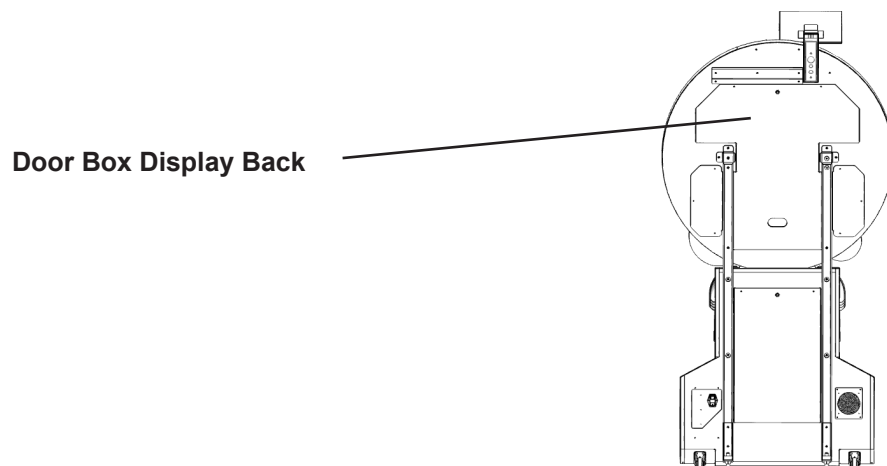

6-3 INSTALLING THE BILLBOARD

- 1 From the rear of the Cabinet, raise the Billboard into position and insert as shown

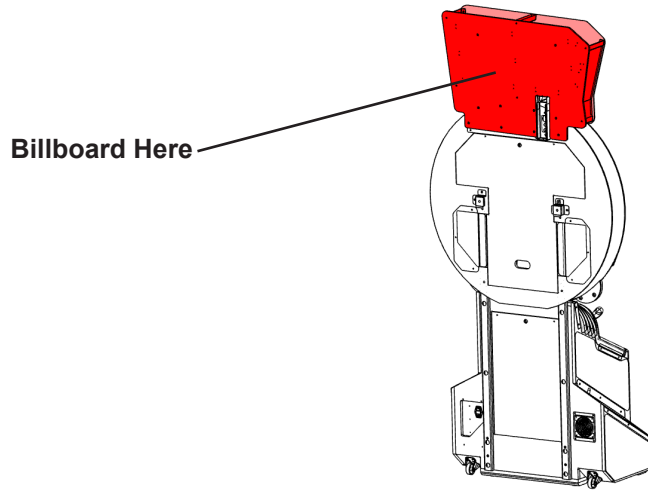

- 2 Secure using the (6) highlighted fixings

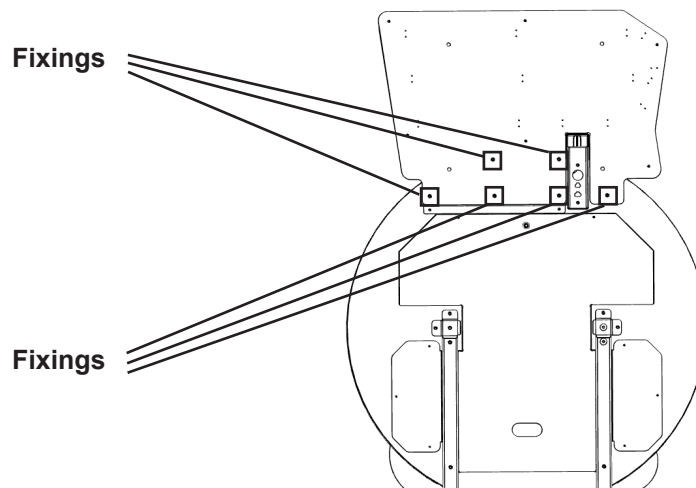

- 3 Feed the harnessing of the Billboard through the hole in the Bonus Box Bracket and connect to the location shown

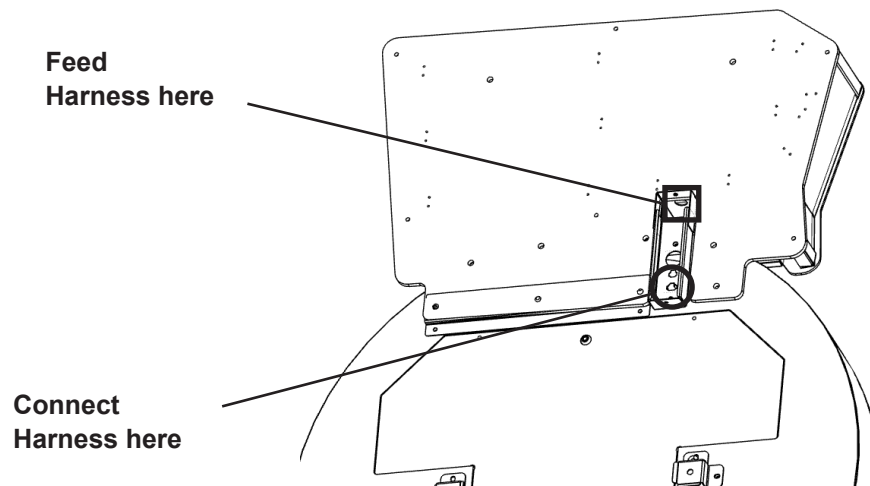

4 Apply and secure Cover Back Box using the (2) fixings (one fixing on the top, one fixing on the bottom)

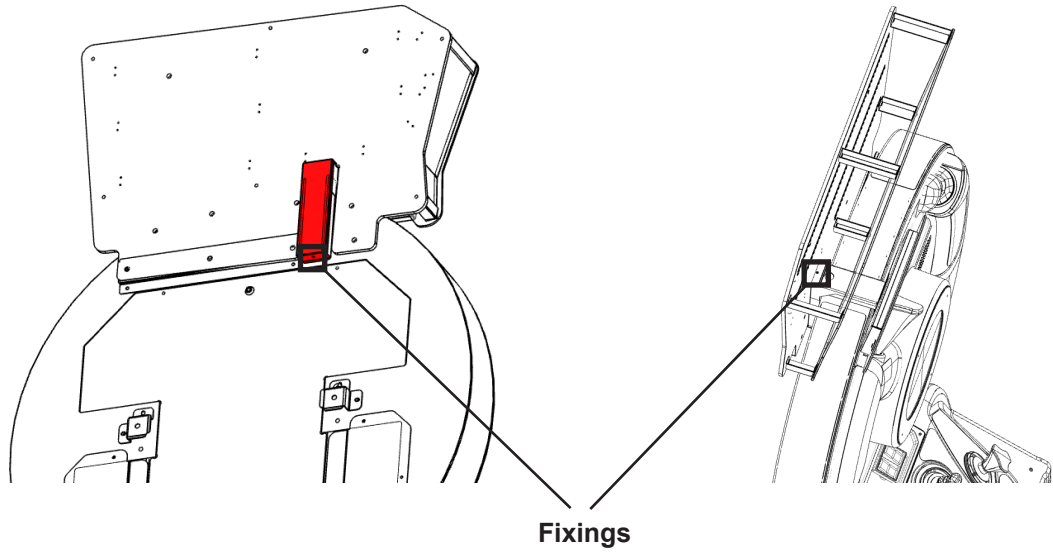

5 Apply the Plate Bonus Box artwork into the position shown using the (2) M6 fixings and self-clinch nuts on each side

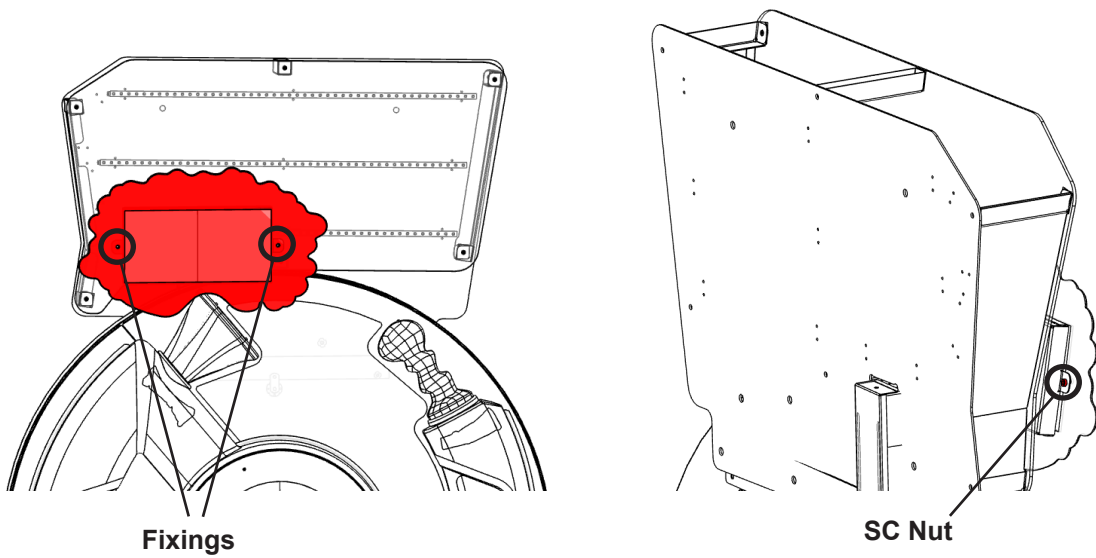

6-4 FIXATION TO INSTALLATION SITE

WARNING

Make sure that all the adjusters contact the floor. Otherwise the Cabinet could move, causing an accident

The product comes with castors attached at 2 locations and adjusters at 2 locations. When the installation site has been determined, have the adjusters come in direct contact with the floor. Establish a gap of about 5 mm between the floor and the castors and adjust the unit so that it will remain level.

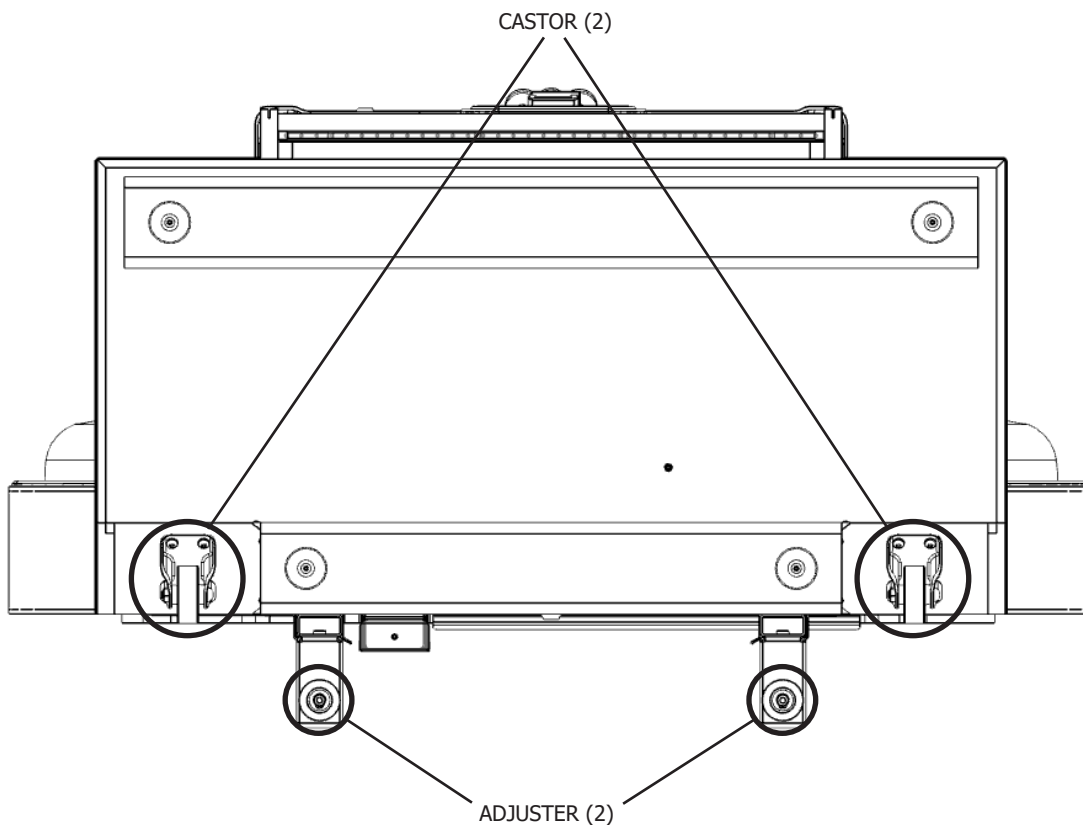

- 1** Move the product to the installation site. If the product is to be installed near a wall, secure enough passageway space for players to access the seat. You must also secure a 15cm space between the back wall and the back of the cabinet for ventilation
- 2** Bring the adjusters into direct contact with the floor. Use a wrench to align the height of the adjusters until the Cabinet is perfectly level
- 3** After setting, turn adjuster nuts upwards to tighten them and secure adjuster heights

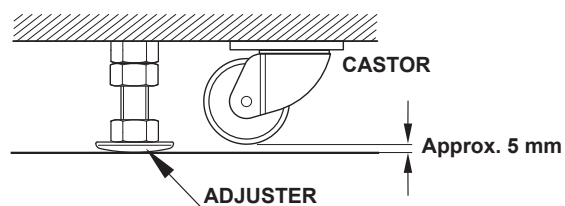
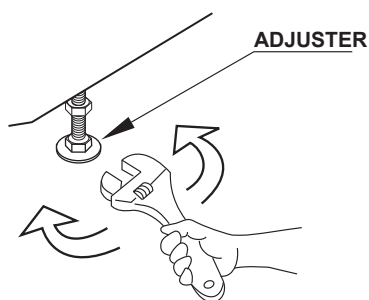

CONNECTION OF POWER AND GROUND CABLES

(Only applies where an integral earth is not present in the mains/power lead.)

WARNING

- Use the power supply equipped with an earth leakage breaker. Use of power supply without such a breaker could result in fire if there is a current leakage
- Have available a securely grounded indoor ground terminal. Without proper grounding, customers could be electrocuted and product operations might not always be stable
- Do not expose the power cord or ground wire. If these are exposed, customers could stumble over them, for instance, and easily damage them. Additionally, if these lines are damaged, there could be a risk of electrical shock or short circuit. Set these lines at locations where they will not interfere with customer traffic, or attach covers to them
- After laying out the power cord on the floor, be sure to always protect it. If the power cord is left exposed, it can easily be damaged, resulting in electrical shock
- When using the product's AC unit ground terminal, use ground wire with a circular terminal as shown in the illustration, and establish ground securely. Avoid indiscriminate grounding operations such as use of wire with only its sheath peeled off

STOP IMPORTANT

If grounding has been established with the ground wire inside the power cord, do not perform grounding with the AC unit ground terminal. Conversely, if the AC unit ground terminal has been used for grounding, do not establish ground with the ground wire in the power cord. Otherwise there could be faulty or erroneous operations

- 1 Confirm that the main switch is at OFF

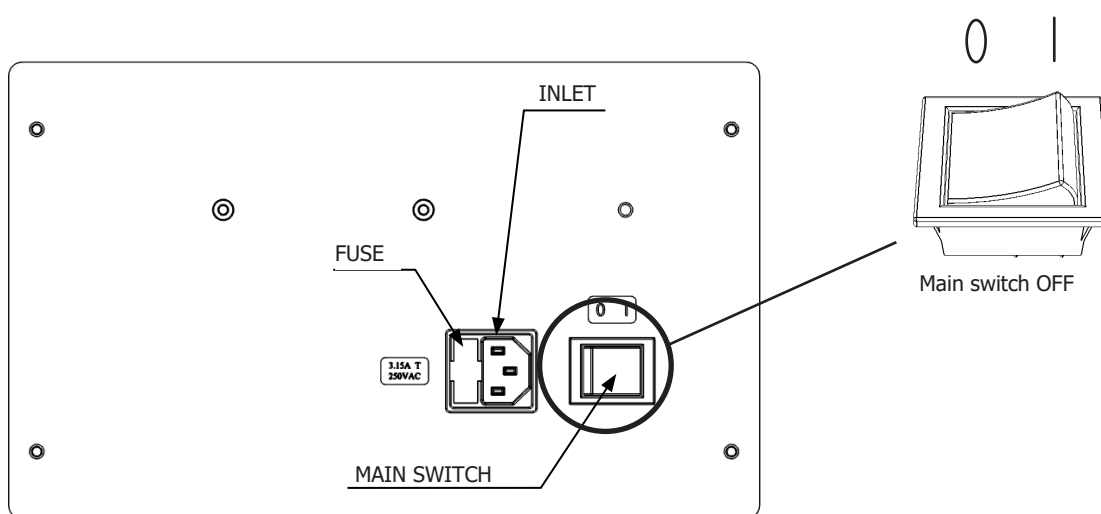

- 2 Fully insert the power cord connector on the side opposite the power plug into the AC unit inlet

- 3 Fully insert the power cord plug into the outlet

- 4 The power cord is laid out indoors. Protect the power cord by attaching wire cover to it. If ground will be established with a ground wire made available separately, lay out the ground wire indoors and have it protected

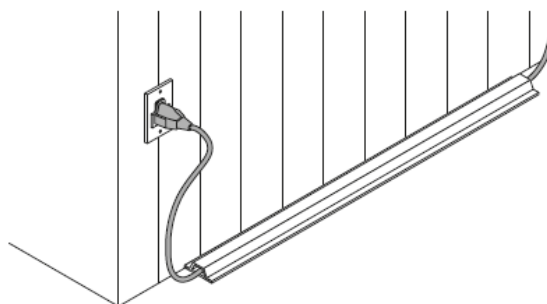

6-5 CONFIRMATION OF INSTALLATION

Use Test Mode to confirm that assembly is proper, connecting boards, and input/output devices are normal. See Section 9 “Test and Service Data” for more information on each individual test.

Perform the following tests in Test Mode:

- 1 Unlock and open the Coin Door to access the SW Unit. Use the Test Button to enter the Test and Service Menu

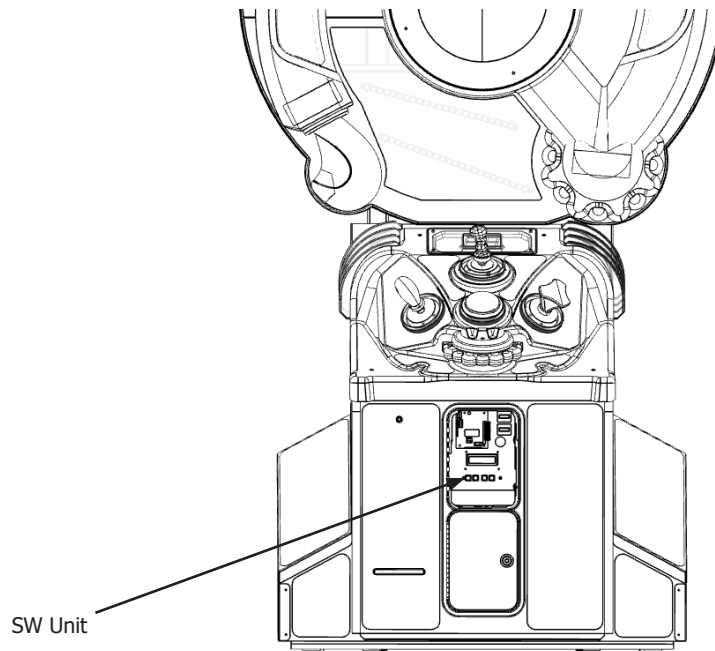

- 2 Enter the section “Input Test”. Ensure all Controller components and Buttons are functioning correctly
- 3 Enter the section “Output Test”. Ensure all LEDs and speakers are functioning correctly

6-6 COMPONENTS THAT CHANGE STATE UPON POWERING UP

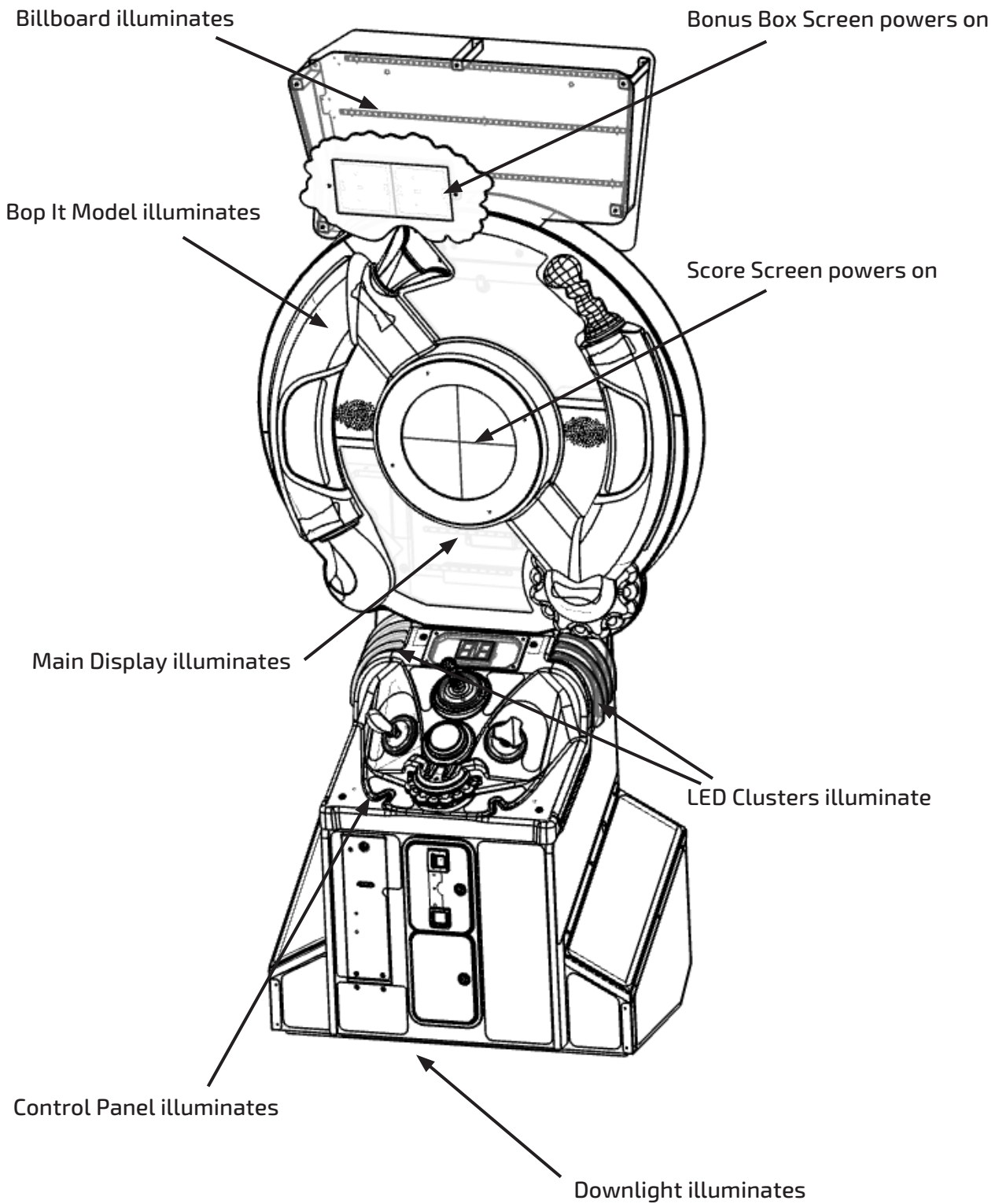

6-7 REPLACING TICKETS

1 Unlock and open the Ticket Mech Door that needs loading or replacing

Unlock Ticket Door here

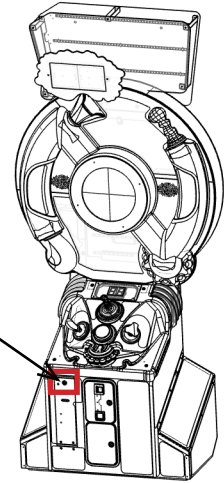

2 Load tickets into the Ticket Mech as shown below and feed into the dispensing track



3 Ensure tickets are vended correctly by pressing the Test Button on the Ticket Mech (tear off and remove excess tickets that are vended after testing)



4 Close Ticket Mech Door and ensure lock is secure

7 PRECAUTIONS WHEN MOVING

7-1 MOVING THE MACHINE

WARNING

- Always disconnect the power cable before moving the product. If it is moved with the power cable connected, the cable could be damaged, causing fire or electric shock
- To move the unit over the floor, pull in the adjusters and have the castors contact the floor. While moving the unit, be careful that the castors do not roll over the power cord or the ground wire. If cord or wire is damaged, there could be electrical shocks and/or short circuits
- When crossing a sloped or stepped area, disconnect the individual pieces of the Cabinet. If you tilt them while connected together, the connection points may be damaged and personnel could be injured
- When lifting the Cabinet up steps, you must hold it by the designated handles or by the bottom surface. Lifting it by any other area may lead to damage or disfiguration to that part or surrounding parts due to the weight of the Cabinet and could also lead to injury of personnel
- When tilting the Cabinet to move it across a sloped or stepped area, always use at least two people. Attempting such an operation alone can lead to accident or injury
- When moving the components separately, take care concerning the direction you push the each Cabinet section in. These elements may fall over, causing damage or an accident

CAUTION

- When moving the components, do not push any of the plastic elements or shaped parts and do not use them to pull the components along. This may damage the parts or the surrounding parts and this could lead to accidents or injury
- When moving the separated components, be sure to push/pull each Cabinet piece lengthways. Trying to move the Cabinet any other way may cause the Cabinet to topple over

STOP IMPORTANT

7 PRECAUTIONS WHEN MOVING THE MACHINE

- When moving the Cabinet, do not hold, push, or pull the Control Units. This may disfigure or damage them
- If you need to move components through a narrow or low door and the only way to get the separated components through is to turn them on their side, or if a separation method other than those described in this Manual is required, either make a request to the office listed in this document or the place of purchase to perform the operation or contact them regarding how to perform it. Carelessly turning the components onto their side or separating them in ways other than those depicted in this Manual may lead to irreparable damage
- Do not press any of the display screens. The screens can be easily damaged and cannot be repaired if it is, meaning complete replacement will be necessary

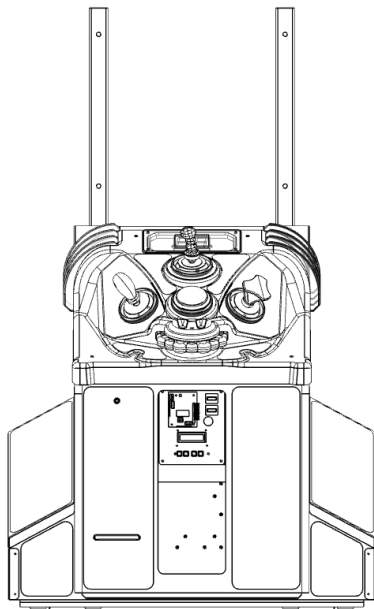

Assy Main Cab

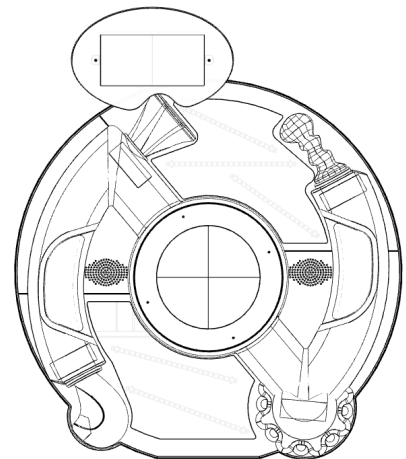

Assy Main Display

8 GAME DESCRIPTION

8-1 GAME OUTLINE

Coin system can accumulate up to 24 Credits. Credits beyond 24 will not be counted and returned to Player. When the 24 Credit limit is reached, it will be recorded in the Test Menu under Coin Settings > Coin Count. It will also be recorded physically on the Credit Board.

In this game the player is tasked with following the instructions called out by the game and inputting them using the specific game controls:

- **Bop it!** (Central button)
- **Flick it!** (Green lever at the top of the inputs panel)
- **Pull it!** (Retractable/pullable blue lever on left side)
- **Spin it!** (Red cog shaped wheel at the bottom of the inputs)
- **Twist it!** (3-sided yellow knob on the right side of the inputs)

When the game makes a callout, the player will need to follow that instruction on the corresponding game control.

The player's goal is to earn as many tickets as possible by inputting the calls outs correctly. The call outs will be represented with an audible phrase & lighting that can show the player what input is needed.

The difficulty can be adjusted as follows:

Easy – The inputs will only have coloured LEDs showing the player the correct input to use during game play.

Medium – All inputs will have white LEDs throughout gameplay and will have coloured LEDs on the correct call out input.

Hard – In this mode all the inputs will have white LEDs on, but there will not be any coloured LEDs at all, to show the player what input to do.

While the player is in game, they need to correctly input 10 callouts for the game to “level up” and increase the speed of the window that the player can input the callout. There are 10 levels in total, when the player reaches level 7 it will stay at a constant speed until the player fails. A player will be told by the game when the level is increasing.

A super bonus can be awarded to the player if they can achieve a score that is set in the test menu. The “high score” & “bonus score” scores will reduce in value after X number of games to allow other players to have a realistic chance to be able to achieve either of these. The super bonus amount can be set in the test menu.

When the player misses an input or uses the incorrect input, the game will end and vend the player the number of tickets shown at the top of the middle LED matrix screen during play.

If the player does this during the first 10 inputs of the game, they are allowed a grace period of a 3 lives mechanic. When the player fails any input on their 3rd life, the game will end.

There are no extra modes to this game.

This page contains parameter adjustment functions for Game Modes. For more detail on Game Settings see TEST MODE – GAME SETTINGS.

- Pressing the TEST button will activate the selected Game Setting Function
- Pressing the SERVICE button will move to the next available test function.

The following settings are set as default at manufacturing.

DESCRIPTION	SETTING	RANGE	DETAIL
Set Cost Of Play	1.00	FreePlay, 0.05 – 5.00	
Set COIN 1	1	0 - 10	
Set COIN 2	0	0 - 10	
Set BILL VALIDATOR	0	0 - 10	
Set Ticket Value	0.01	0.001 – 0.10	
Set Ticket Mode	FULL	FULL / HALF	FULL - 2 Ticket Win pays 2 physical tickets. HALF - 2 Ticket Win pays 1 physical ticket.
Bonus Ticket Max	1000	100-9999	
Bonus Target Min	70	38 – 99	The value the player must reach/ beat to win the Bonus Tickets.
Bonus Target Inc	5	1 - 10	This sets the amount the BONUS TARGET value increases by after a Bonus Ticket win.
High Score (HS) Clear	500	1 - 5000	This sets the point the High Score is reset back to 20.
Mercy Tickets	0	1 – 20	
Difficulty	Medium	Easy/Medium/Hard	Easy – This lights each controller its designated colour when called. All other controller lighting remains OFF. This is a visual aid to which controller is active. Medium – This lights a controller its designated colour when called. All other controller lighting is lit White. This is a visual aid to which controller is active but adds a level of confusion. Hard – This sets all controller lighting to White giving no individual visual indication which controller is active.
Set Call Out Tkt 1	1	0 - 2	Sets the Call Out Ticket Value for Level 1.
Set Call Out Tkt 2	1	1 - 4	Sets the Call Out Ticket Value for Level 2.
Set Call Out Tkt 3	1	1 - 6	Sets the Call Out Ticket Value for Level 3.
Set Call Out Tkt 4	1	1 - 8	Sets the Call Out Ticket Value for Level 4.
Set Call Out Tkt 5	1	1 - 10	Sets the Call Out Ticket Value for Level 5.
Set Call Out Tkt 6	1	1 – 12	Sets the Call Out Ticket Value for Level 6.
Set Call Out Tkt 7	1	1 - 14	Sets the Call Out Ticket Value for Level 7.
Set Call Out Tkt 8	1	1 - 14	Sets the Call Out Ticket Value for Level 8.
Set Call Out Tkt 9	1	1 - 14	Sets the Call Out Ticket Value for Level 9.
Set Call Out Tkt 10	1	1 - 14	Sets the Call Out Ticket Value for Level 10.
Set Active Time 1	2.00s	3.00s, 2.50s, 2.00s, 1.75s, 1.50s, 1.25s, 0.75s, 0.50	The period each controller is active in seconds
Set Active Time 2	1.75s	-	The period each controller is active in seconds
Set Active Time 3	1.50s	-	The period each controller is active in seconds
Set Active Time 4	1.25s	-	The period each controller is active in seconds
Set Active Time 5	1.00s	-	The period each controller is active in seconds
Set Active Time 6	0.75s	-	The period each controller is active in seconds
Set Active Time 7	0.50s	-	The period each controller is active in seconds
Set Active Time 8	0.50s	-	The period each controller is active in seconds
Set Active Time 9	0.50s	-	The period each controller is active in seconds
Set Active Time 10	0.50s	-	The period each controller is active in seconds

9 EXPLANATION OF TEST AND DATA DISPLAY

WARNING

Do not touch any parts that are not specified in these directions. Touching unspecified locations may lead to electric shock or cause short circuits

CAUTION

- Be careful that your finger or hand does not get caught when opening/closing the coin chute door

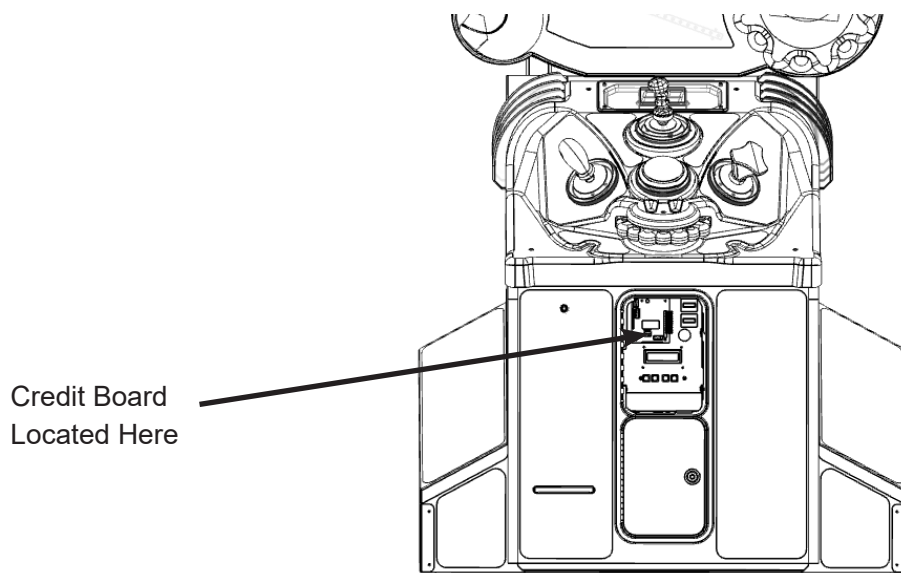

IMPORTANT

- When you enter the Test Mode, Fractional Coin data is erased
- Adjust the sound to the optimum volume, taking into consideration the environmental requirements of the installation location
- Removing the Coin Meter circuitry renders the game inoperable
- Have a flashlight on hand and operate in Test Mode very carefully. The Cabinet interior is dark and narrow and you could easily make mistakes in operation

Perform tests and data checks periodically by manipulating the TEST Button and SERVICE Button in the Cabinet. Follow the instructions in this chapter to conduct checks when the game machine is first installed, when money is being collected, or when the game machine does not operate properly.

9-1 SWITCH UNIT AND COIN METER

The Swith Unit and Counters are housed within the Coin Tower. To access these controls you will need to open the Coin Door. The switches and counters can be found directly on the rear face of the Tower.

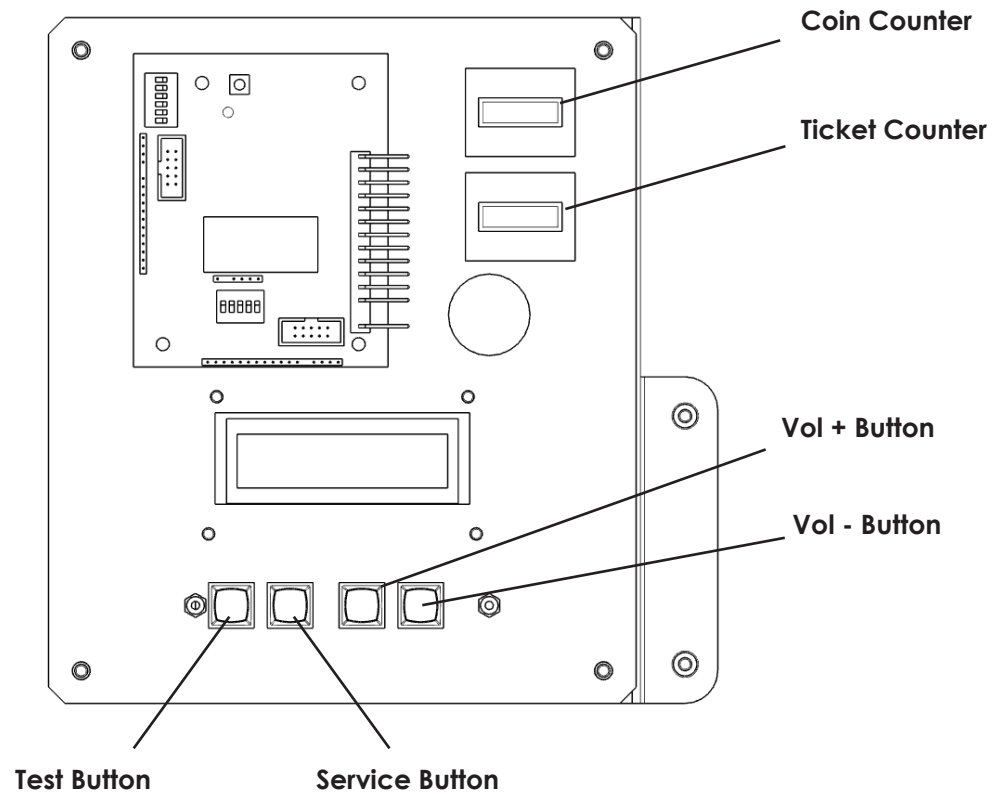

DEVICE	FUNCTION
TEST BUTTON	Press to enter TEST MODE - Also used to enter choices selected within TEST MODE
SERVICE BUTTON	Press for SERVICE CREDIT - Also used to scroll through TEST MENUs
COIN IN COUNTER	Counts inserted coins (£0.10 or \$0.10 = 1 count)
VOLUME +/-	Adjusts audio level

9-2 GAME TEST MODE

TEST MODE

Test Mode is entered by pressing the TEST button. The cabinet LED Matrix will display the word “test “

TEST FUNCTIONS

NOTE:

The term ‘CALL’ and ‘CALL OUT’ used within these instructions refer to the vocal instructions to action the BOP IT - TWIST IT - FLICK IT - PULL IT - SPIN IT controllers.

1. GAME SETTINGS

○ Set Cost Of Play

```
SET COST OF PLAY  
SETTING: 1.00
```

- This function only sets Cost of Play.
- To change to cost of play to the Player, the Credit Board settings should be used.
- Pressing the TEST button will cycle through the following values:
 - FREEPLAY, 0.05, 0.10, 4.90, 4.95, 5.00 (Increments of 0.05)

○ Set COIN Pulse.

```
COIN 1  
SETTING: 1
```

*SET TO – 0 for cabinets fitted with the EXCEL
Credit Board.*

- This sets how many Credit pulses required to start the game.
- Range 0 - 10

```
COIN 2  
SETTING: 0
```

*SET TO – 0 for cabinets fitted with the EXCEL
Credit Board.*

- This pulse is equal to the cost of the game. Use as a multiplier for credits.
- Range 0 - 10

```
BILL VALIDATOR  
SETTING: 0
```

- This pulse is equal to the cost of the game. Use as a multiplier for credits.
- Range 0 – 10

****For cabinets fitted with an Excel Credit Board Set Coin 1 = 1, Coin 2 = 0****

○ Set Ticket Value

```
SET TICKET VALUE
VALUE: 0.01
```

- This function sets Ticket Value. Pressing the TEST button will cycle through the following values:
 - 0.001, 0.002, 0.005, 0.01, 0.02, 0.03, 0.04, 0.05, 0.06, 0.07, 0.08, 0.09, 0.10

○ **Set Ticket Mode**

```
SET TICKET MODE
SETTING: FULL
```

- This function sets Ticket Value with respect to FULL value or HALF value.
- Pressing the TEST button will cycle through the following options:
 - FULL
 - HALF

○ **Set Bonus Tickets**

```
BONUS TICKET MAX
VALUE: 1000
```

- This function sets the Bonus Maximum Value
- Pressing the TEST button will cycle through the following values:
 - 100, 200, 300, 400, 500, 600, 700, 800, 900, 1000, 2000, 5000, 9999

○ **Bonus Target Min**

- This is the value the player must reach/ beat to win the Bonus Tickets

```
BON TARGET SCORE
VALUE: 70
```

Default Setting

- Pressing the TEST button will cycle through the following values:
 - 34 – 99 in increments of one.

○ **Bonus Target Increment**

```
BONUS SCORE
INC VALUE: 5
```

Default Setting

- This sets the amount the BONUS TARGET value is increased by after a Bonus Ticket win.
- Pressing the TEST button will set the BT incremental step by the following values:
 - 1 – 10 in increments of 1.

In this example once the player has reached 55 call outs, they are awarded the bonus tickets and the Bonus Score increases by 5 to 60.

If the player does not reach the Bonus Target Score the Bonus Target Score decrements by 1 - this decremental value is not adjustable.

○ **High Score Clear**

```
HS CLEAR INTRVAL
SETTING: 500
```

Default Setting

- This sets the number of games played before the high score is reset to a default value of 20.
- Pressing the TEST button will cycle through the following values: 1, 2, 5, 10, 20, 50, 100, 200, 500, 1000, 2000, 5000

○ **Set Mercy Tickets**

```
SET MERCY TICKET
SETTING: 0
```

Default Setting

- This function allows a mercy ticket to be set.
- Pressing the TEST button will cycle through the following values: 0,1,.....19, 20

○ **Game Difficulty**

```
DIFFICULTY
SETTING: MEDIUM
```

Default Setting

- This sets the game difficulty level between EASY, MEDIUM & HARD.

- **Easy** – This lights each controller its designated colour when called. All other controller lighting remains OFF. This is a visual aid to which controller is active.
- **Medium** – This lights a controller its designated colour when called. All other controller lighting is lit White. This is a visual aid to which controller is active but adds a level of confusion.
- **Hard** – This sets all controller lighting to White giving no individual visual indication which controller is active.

○ **Set Call Out Ticket Values**

Default Setting

```
SET CALL TKT
GAME 1-10: 1
```

- This sets the ticket value for games 1 – 10 (Zone 1)
- Ticket range 0 - 2
- Pressing the TEST button will cycle through increments of 1.

○ **Set Call Out Ticket Values**

```
SET CALL TKT
GAME 11-20: 1
```

Default Setting

- This sets the ticket value for games 11 - 20. (Zone 2)
- Ticket range 1 - 4
- Pressing the TEST button will cycle through increments of 1.

○ **Set Call Out Ticket Values**

```
SET CALL TKT
GAME 21-30: 1
```

Default Setting

- This sets the ticket value for games 21 - 30. (Zone 3)
- Ticket range 1 - 6
- Pressing the TEST button will cycle through increments of 1.

○ **Set Call Out Ticket Values**

```
SET CALL TKT
GAME 31-40: 1
```

Default Setting

- This sets the ticket value for games 31 - 40. (Zone 4)
- Ticket range 1 - 8
- Pressing the TEST button will cycle through increments of 1.

○ **Set Call Out Ticket Values**

```
SET CALL TKT
GAME 41-50: 1
```

Default Setting

- This sets the ticket value for games 41 - 50. (Zone 5)
- Ticket range 1 - 10
- Pressing the TEST button will cycle through increments of 1.

○ **Set Call Out Ticket Values**

Default Setting

```
SET CALL TKT
GAME 51-60: 1
```

- This sets the ticket value for games 51 - 60. (Zone 6)
- Ticket range 1 - 12
- Pressing the TEST button will cycle through increments of 1.

○ **Set Call Out Ticket Values**

```
SET CALL TKT
GAME 61-70: 1
```

Default Setting

- This sets the ticket value for games 61 - 70. (Zone 7)
- Ticket range 1 - 14
- Pressing the TEST button will cycle through increments of 1.

○ **Set Call Out Ticket Values**

```
SET CALL TKT
GAME 71-80: 1
```

Default Setting

- This sets the ticket value for games 71 - 80. (Zone 8)
- Ticket range 1 - 14
- Pressing the TEST button will cycle through increments of 1.

○ **Set Call Out Ticket Values**

```
SET CALL TKT
GAME 81-90: 1
```

Default Setting

- This sets the ticket value for games 81 - 90. (Zone 9)
- Ticket range 1 - 14
- Pressing the TEST button will cycle through increments of 1.

○ **Set Call Out Ticket Values**

```
SET CALL TKT
GAME 91-99: 1
```

Default Setting

- This sets the ticket value for games 91 - 99. (Zone 10)
- Ticket range 1 - 14
- Pressing the TEST button will cycle through increments of 1.

○ **Set Call Out frequency intervals.**

Default Setting

```
SET ACTIVE TIME1
SETTING: 2.00s
```

- This sets the period each controller is active for during games 1 - 10.
- Range 3.00s, 2.50s, 2.00s, 1.75s, 1.50s, 1.25s, 1.00s, 0.75s, 0.50s
- Pressing the TEST button will cycle through setting options.

- Set Call Out frequency intervals.

```
SET ACTIVE TIME2
SETTING: 1.75s
```

Default Setting

- Set Call Out frequency intervals.

```
SET ACTIVE TIME3
SETTING: 1.50s
```

Default Setting

- Set Call Out frequency intervals.

```
SET ACTIVE TIME4
SETTING: 1.25s
```

Default Setting

- Set Call Out frequency intervals.

```
SET ACTIVE TIME5
SETTING: 1.00s
```

Default Setting

- Set Call Out frequency intervals.

```
SET ACTIVE TIME6
SETTING: 0.75s
```

Default Setting

- Set Call Out frequency intervals.

```
SET ACTIVE TIME7
SETTING: 0.50s
```

Default Setting

- Set Call Out frequency intervals.

```
SET ACTIVE TIME8
SETTING: 0.50s
```

Default Setting

- Set Call Out frequency intervals.

Default Setting

```
SET ACTIVE TIME9
SETTING: 0.50s
```

- **Set Call Out frequency intervals.**

```
SET ACTIVE TIME10
SETTING: 0.50s
```

Default Setting

- **FREE GAME MODE – (PLAY FOR FUN ONLY)**

- **Exiting Game Settings**

- After making Game Setting changes you will be prompted to confirm your decision.

```
B/KEEPING RESET
REQUIRED OK? Y/N
```

- Select Y to confirm.

2. BOOKKEEPING

- **General**

- Bookkeeping contains logged data regarding Game Performance.
- Pressing the TEST button will activate the selected Bookkeeping Function
- Pressing the SERVICE button will move to the next available Bookkeeping display.

- **Operation**

- **Bookkeeping Screen 1**

```
CREDITS=000010
SERVICE=000002
```

- CREDITS – Total number of COIN credits entered.
- SERVICE – Total number of SERVICE credits entered.

- **Bookkeeping Screen 2**

```
GAMES=00000000
TICKETS=00000000
```

- GAME – Total number of Games Played
- TICKETS– Total number of tickets paid out.

- **Bookkeeping Screen 3**

```
AV TCKET = 000030
AV SCORE = X
```

- AV TCKET – The average amount of tickets paid out per game.
- AV SCORE – The average score value.

○ **Bookkeeping Screen 4**

```
BNS 1 IN = X
BNS WIN = X
```

- BNS 1 IN – The drop frequency of the Bonus.
- BNS WIN – How many players win the bonus round.

○ **Bookkeeping Screen 5**

```
ZONE 1 = X
ZONE 2 = X
```

- ZONE 1 – The number of C/Outs won in Zone 1.
- ZONE 2 – The number of C/Outs won in Zone 2.

○ **Bookkeeping Screen 6**

```
ZONE 3 = X
ZONE 4 = X
```

- ZONE 3 – The number of C/Outs won in Zone 3.
- ZONE 4 – The number of C/Outs won in Zone 4.

○ **Bookkeeping Screen 7**

```
ZONE 5 = X
ZONE 6 = X
```

- ZONE 5 – The number of C/Outs won in Zone 5.
- ZONE 6 – The number of C/Outs won in Zone 6.

○ **Bookkeeping Screen 8**

```
ZONE 7 = X
ZONE 8 = X
```

- ZONE 7 – The number of C/Outs won in Zone 7.
- ZONE 8 – The number of C/Outs won in Zone 8.

○ **Bookkeeping Screen 9**

ZONE 9	=	X
ZONE 10	=	X

- ZONE 9 - The number of C/Outs won in Zone 9.
- ZONE 10 - The number of C/Outs won in Zone 10.

○ **Bookkeeping Screen 10**

MERCY	=	X
CONTINUE	=	X

- MERCY - The number of Mercy games played.
- CONTINUE - The number of games played within 10s of the previous game.

○ **Bookkeeping Screen 11**

TWIST	=	X
FLICK	=	X

- % Success rate TWIST achieved.
- % Success rate FLICK achieved.

○ **Bookkeeping Screen 12**

- % Success rate BOP IT achieved.
- % Success rate PULL IT achieved.

○ **Bookkeeping Screen 13**

SPIN IT	=	X
Z1 REACH	=	X

- % Success rate SPIN It achieved.
- Z1 REACH = The number of games that ended in Zone 1

○ **Bookkeeping Screen 14**

Z2 REACH	=	X
Z3 REACH	=	X

- Z2 REACH = The number of games that ended in Zone 2
- Z3 REACH = The number of games that ended in Zone 3

○ **Bookkeeping Screen 15**

- Z4 REACH = The number of games that ended in Zone 2
- Z5 REACH = The number of games that ended in Zone 3

○ **Bookkeeping Screen 15**

- Z4 REACH = The number of games that ended in Zone 4
- Z5 REACH = The number of games that ended in Zone 5

- **Bookkeeping Screen 16**
 - Z4 REACH = The number of games that ended in Zone 4
 - Z5 REACH = The number of games that ended in Zone 5
- **Bookkeeping Screen 17**
 - Z6 REACH = The number of games that ended in Zone 6
 - Z7 REACH = The number of games that ended in Zone 7
- **Bookkeeping Screen 18**
 - Z8 REACH = The number of games that ended in Zone 8
 - Z9 REACH = The number of games that ended in Zone 9
- **Bookkeeping Screen 19**
 - Z10 REACH = The number of games that ended in Zone 10

- **Bookkeeping Screen 20**

```
1 LIFE = X
2 LIFE = X
```

- The number of time LIFE 1 & 2 have been used.

- **Clear Meters**

```
CLEAR METERS
```

- Pressing TEST will prompt the Operator “Are You Sure”?
- Pressing TEST a second time will clear all bookkeeping meters to ZERO
- A confirmation message “ALL CLEARED” will be shown and a confirmation audio SFX will be played

- **Clear IOU & Service meters**

- The above procedure is repeated for clearing the IOU & Service Meters

3. SYSTEM INFO

- General
 - System Info contains general information and version numbers for system hardware and software
 - Pressing the SERVICE button will cycle through the available test functions.
 - Pressing the TEST button will activate the selected Test Function

- Operation

- Game Name and Version Info

```
BOP IT ARCADE
Version 1.00S
```

- Hardware and Serial Number Info

```
BOOTLOADER: v1.0
Serial: 0123ABCD
```

4. LIGHTING TEST

- General
 - Lamp Test contains test functions for the lighting elements of the Cabinet
 - Pressing the TEST button will activate the selected Test Function
- Operation
 - **All Lamps Test**

```
All Lamps
off
```

- When OFF is displayed, all lamps in the cabinet will be OFF
- Pressing TEST button will toggle the Lamp state from OFF to ON.
- When ON is displayed, all lamps in the cabinet will be ON
- This includes any lighting driven from CAN bus devices.

- **Direct LED Outputs**

```
LIGHTING TEST
LED STEP DIRECT
```

- Pressing the TEST button will advance to lamp 000, pressing TEST again will advance to 001 and so on.
- The colour of the Lamp being lit is displayed next to the Lamp ID

- **Lighting Test**

```
LED STEP MUX
MUX: 015 RED
```

- The current Multiplex output being tested is displayed
- Pressing TEST will advance to the next multiplex output to be tested
- The Test will run from ROW 01 to ROW 16, and then test COL 01 to COL 16
- Pressing the SERVICE button will terminate the test.

5. DISPLAY TEST

- General.
 - Display Test contains test functions for the Cabinet 7 segment LED and LED Matrix Displays
 - Pressing the TEST button will activate the selected Test Function
 - Pressing the SERVICE button will move to the next available test function. Any current test operation will be aborted.
- Operation

○ **Display Test**

```
ALL SEGMENTS
SEGMENTS OFF
```

- Pressing TEST will cycle through the 7-SEG LED test modes:
 - ALL OFF – All 7 Segment Display elements are OFF
 - ALL ON – All 7 Segment Display elements are ON

○ **Identify**

```
IDENTIFY
CALOUT = 43
```

- Pressing TEST will display 431 on the TICKETS 7 SEG LED display

○ **Segment Step**

```
SEGMENT STEP
SEGMENT - a
```

- Pressing TEST will step through all seven segments (plus dp) of all displays – A,B,C,D,E,F,G,H.

• LED Matrix Display

○ **Display Test MATRIX**

```
MATRIX
TEST 1 = ALL RED
```

- Pressing TEST will cycle through the LED Matrix test modes.
- TEST1 ALL RED
- TEST2 ALL GREEN
- TEST3 ALL BLUE
- TEST4 ID

BONUS DISPLAY

6	5
---	---

BOP IT DISPLAY

2	1
3	4

```
MATRIX
SHOW IMP = 01
```

- Pressing TEST will cycle through the LED Matrix animations & messages.

6. INPUT TEST

○ Switch Inputs

```
DIL SW1-6 000000
TST-OFF SRV-OFF
```

- The current status of all on-board DIL inputs is shown on the display.
 - "0" indicates a switch is OFF.
 - "1" indicates a switch is ON
- The current status of the TEST & SERVICE inputs is show on row 2 of the LCD display.
- An audio sample will be played whenever an input state changes.
- To exit from Switch Test, press the TEST and SERVICE buttons simultaneously.

○ Controllers TEST

```
CONTROLLERS
BOP IT: OFF
```

- The current status of the BOP IT control is shown.
- An audio sample will be played whenever an input state changes.
- Press the SERVICE button to exit from this test.

```
CONTROLLERS
FLICK IT: OFF
```

- The current status of the TWIST IT control is shown.
- An audio sample will be played whenever an input state changes.
- Press the SERVICE button to exit from this test.

***This is repeated for the remaining controllers - , Pull It, Twist It & Spin It.

○ Opto Input Test

```
INPUT TEST
OPTO INPUTS
```

- The state of the Ticket Opto signal is displayed. The state of the input is changed as a ticket passes through the opto.

7. OUTPUT TEST

○ **Ticket Output**

TICKET OUTPUTS
TICKET VEND

- If TEST is pressed, the Selected Ticket Vend will dispense until the opto signal is received.

TICKET OUTPUTS
VEND OK

○ **Meter Test**

METER OUTPUTS
TEST GAME METER

- If TEST is pressed, the Selected Meter Output will be pulsed one (1) unit to validate the Meter Output driver.
- If Multiple Meter Outputs exist, pressing the SERVICE button will select the next Meter Output.
- The Coin Meter is not accessed via this test.

8. AUX CAN

- General. NOT USED

9. COMS

- Serial Coms. NOT USED

10. AUDIO SETTINGS

- General

- Volume is controlled by Up / Dn pushbuttons located next to the TEST & SERVICE buttons. A minimum volume setting is enabled to ensure the game instructions can be heard irrelevant of the volume control position.
- Pressing the TEST button will activate the selected Audio Function
- Pressing the SERVICE button will move to the next available test function. Any current Audio operation will be aborted.
-
- Operation

- **Audio Settings**

```
AUDIO VOLUME
VOLUME: 25%
```

- Pressing the TEST button will cycle through the default audio volume settings.

```
AUDIO SETTINGS
AUDIO VOLUME MIN
```

- This sets the MINIMUM level the audio volume will be set to.

- **Set Attract Audio Level**

```
ATTRACT AUDIO
SETTING: OFF
```

- Pressing the TEST button will cycle through the following display:
 - OFF – No Audio will play in Attract.

- **Play Audio**

```
PLAY AUDIO
AUDIO: OFF
```

- Pressing the TEST button will cycle through the following display:
 - PLAYING– The Attract Audio sound will loop
 - OFF – No Audio

- **Language**

```
SELECT LANGUAGE
ENGLISH
```

- Pressing the SERVICE button will cycle through the following display:
 - ENGLISH, SPANISH, FRENCH, ITALIAN, PORTUGUESE.
- Pressing the TEST button will select the required language (If supported).

- Set Date

```
SET DATE/TIME  
20/07/22 13:30
```

- Pressing TEST once will activate the Date/Time setting and place a flashing cursor underneath the first field (DATE)
- Pressing the SERVICE button will move the cursor along the fields in the following sequence: DATE → MONTH → YEAR → HOUR → MINUTE → EXIT
- When on a field, pressing the TEST button will advance the value by 1. Pressing and holding TEST for longer than 1 second will increment the value every 0.25 seconds.
- The range for the DATE field will be between 1 and 28, 29, 30 or 31 (depending on the MONTH and YEAR fields)
- The range for the MONTH field will be between 1 and 12
- The range for the YEAR field will be between 1 and 99.
- The range for the HOUR field will be between 00 and 23.
- The range for the MINUTE field will be between 00 and 59

12. EXIT

Exit - Pressing TEST whilst on EXIT test will terminate the test procedures and return to normal game operation.

10 CONTROLLER UNIT

WARNING

- When working with the product, be sure to turn the power off. Working with the power on may cause an electric shock or short circuit
- Be careful not to damage the wires. Damaged wires may cause an electric shock, short circuit or present a risk of fire
- Exercise due caution in performing soldering work. If soldering iron is handled carelessly, there could be fires or burns

CAUTION

- When fastening plastic parts, be careful not to tighten screws or nuts excessively. If these are tightened to excess, parts could be damaged, resulting in injuries from fragments, etc.
- After the unit has been disassembled and reassembled again, check carefully to be sure that there are no gaps or rattling at the junctions and that the trigger can be operated smoothly. If there are gaps or rattling, or if operation is not satisfactory, the players could get fingers or hands caught, resulting in injury
- Be sure to inspect control unit surfaces for cracks and damage. Players could be injured if they play when the unit is cracked or damaged

IMPORTANT

- There is a possibility that the electronic components on the IC Board may be prone to damage by static electricity. Please make sure to discharge any build up of static electricity from your body prior commencing any work
- Power OFF machine before commencing any work

10-1 REMOVING THE CONTROL UNITS

10-1-1 - Removing the "Flick-It" Control Unit

- 1 With the power OFF. Unlock and remove the Door Back Lower

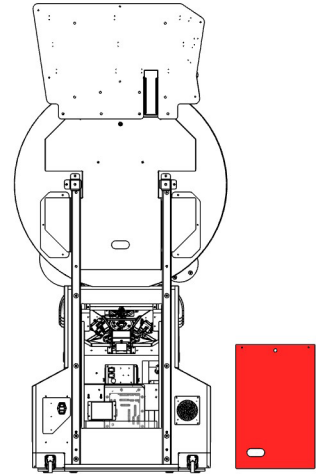

- 2 Disconnect the related harnessing

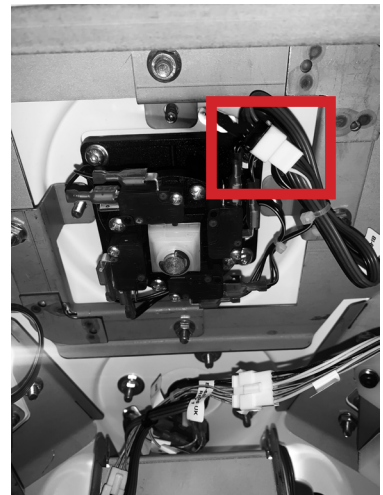

- 3 Remove the (4) flange nuts on the fixings highlighted and remove the assembly

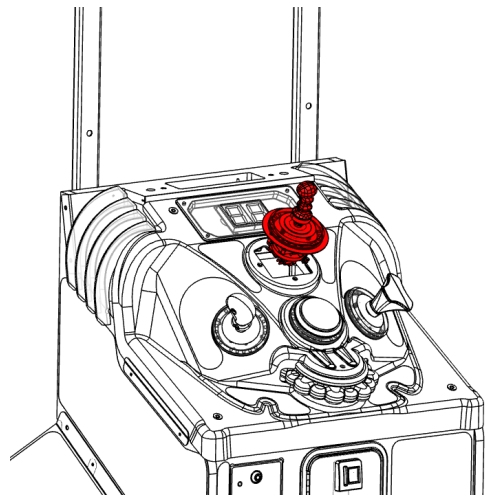
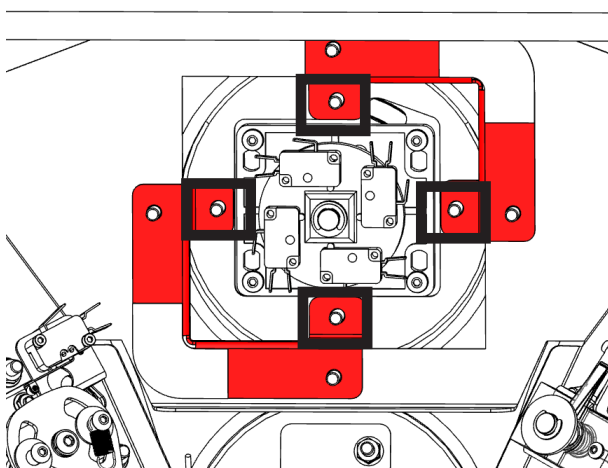

10-1-2 - Removing the "Pull-It" Control Unit

- 1 With the power OFF. Unlock and remove the Door Back Lower

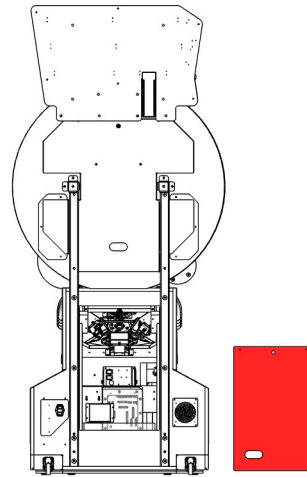

- 2 Disconnect the related harnessing

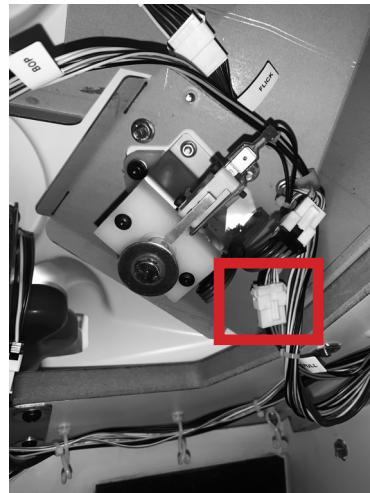

- 3 Remove the (4) flange nuts on the fixings highlighted and remove the assembly

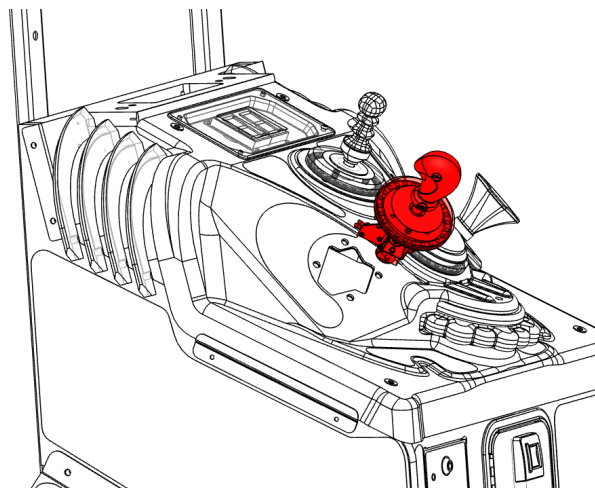
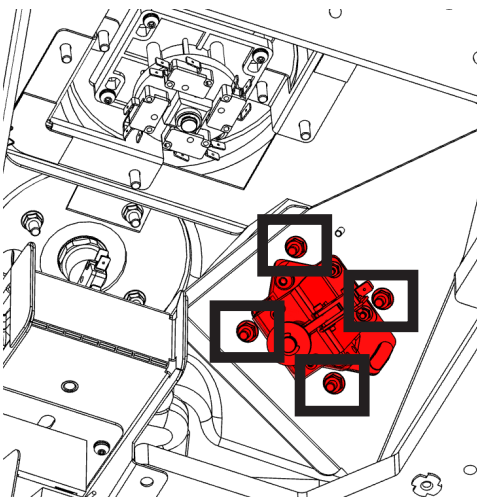

10-1-3 - Removing the "Twist-It" Control Unit

- 1 With the power OFF. Unlock and remove the Door Back Lower

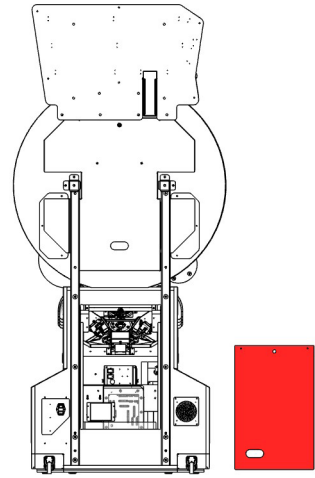

- 2 Disconnect the related harnessing

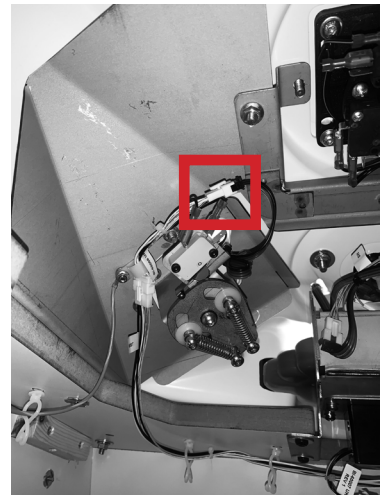

- 3 Remove the (4) flange nuts on the fixings highlighted and remove the assembly

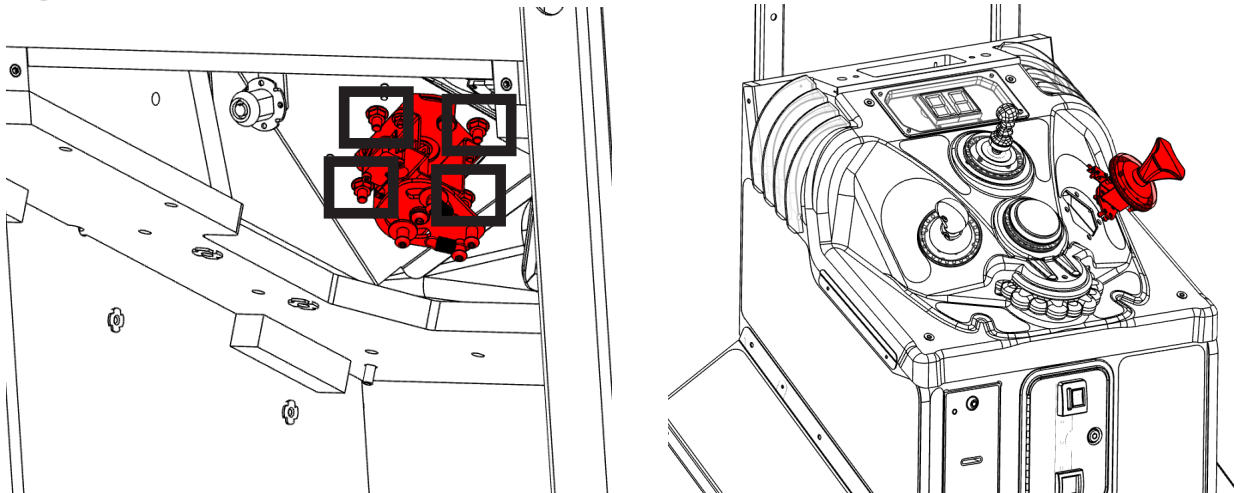

10-1-4 - Removing the "Spin-It" Control Unit

- 1** With the power OFF. Unlock and remove the Door Back Lower

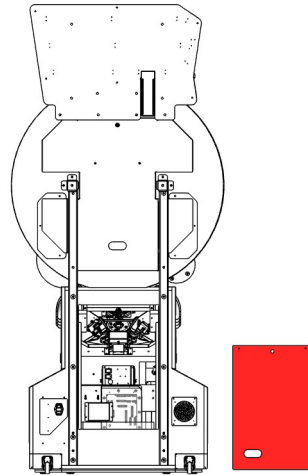

- 2** Disconnect the related harnessing. Remove the (1) fixing from the Cabinet front

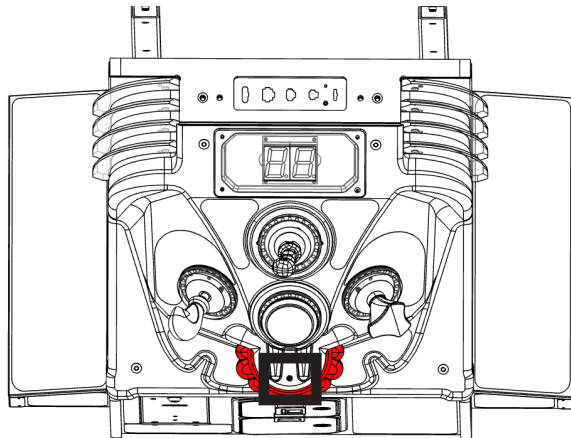
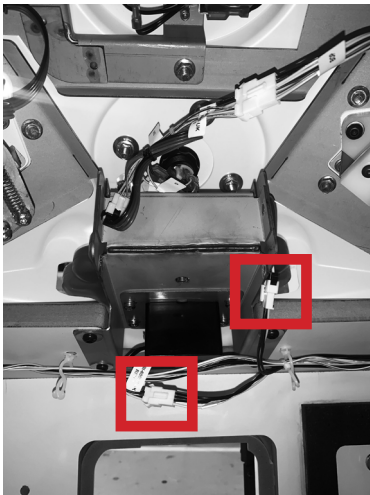

- 3** Remove the (4) M6 fixings highlighted and remove the assembly (be sure to support the controller from underneath when removing these fixings)

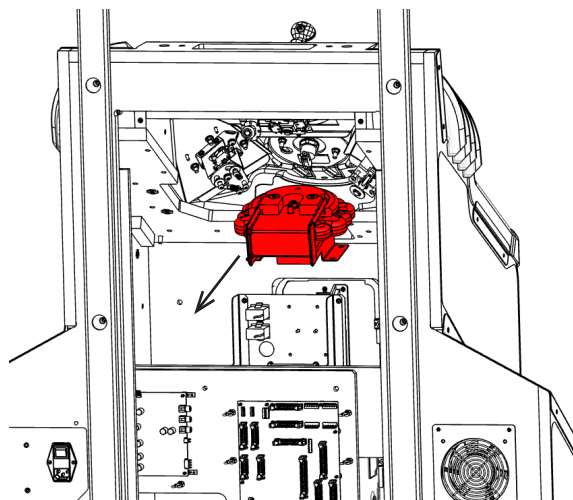
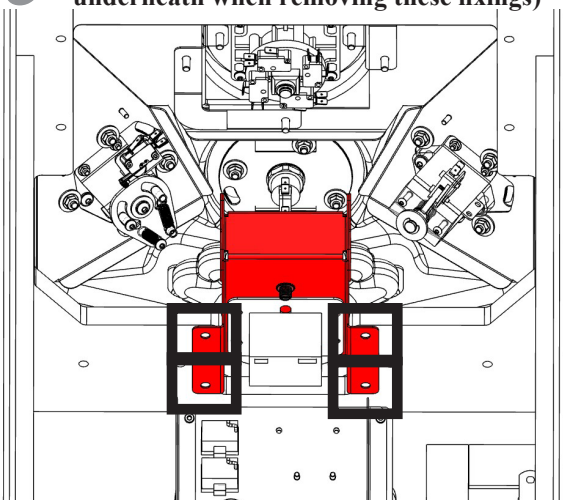

10-1-5 - Removing the "Bop-It" Control Unit

In order to remove the "Bop-It" Controller, the Spin It controller must first be removed. Consult Section 10-1-4 in order to see how the Spin It Controller is removed.

- 1** With the power OFF. Unlock and remove the Door Back Lower

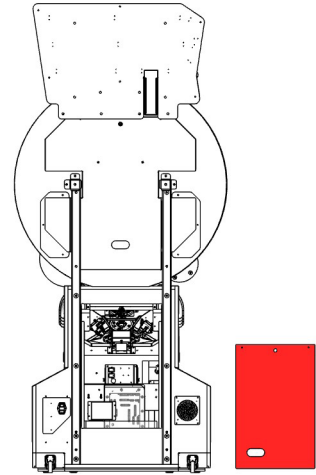

- 2** Disconnect the related harnessing

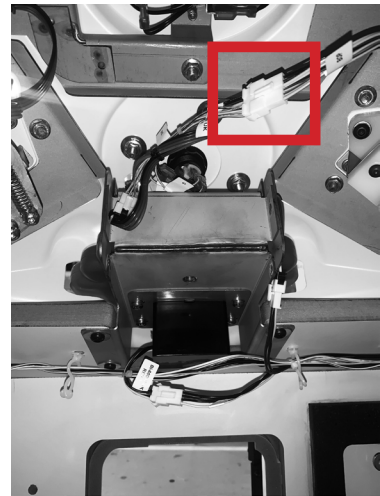

- 3** Remove the (4) flange nuts on the fixings highlighted and remove the assembly

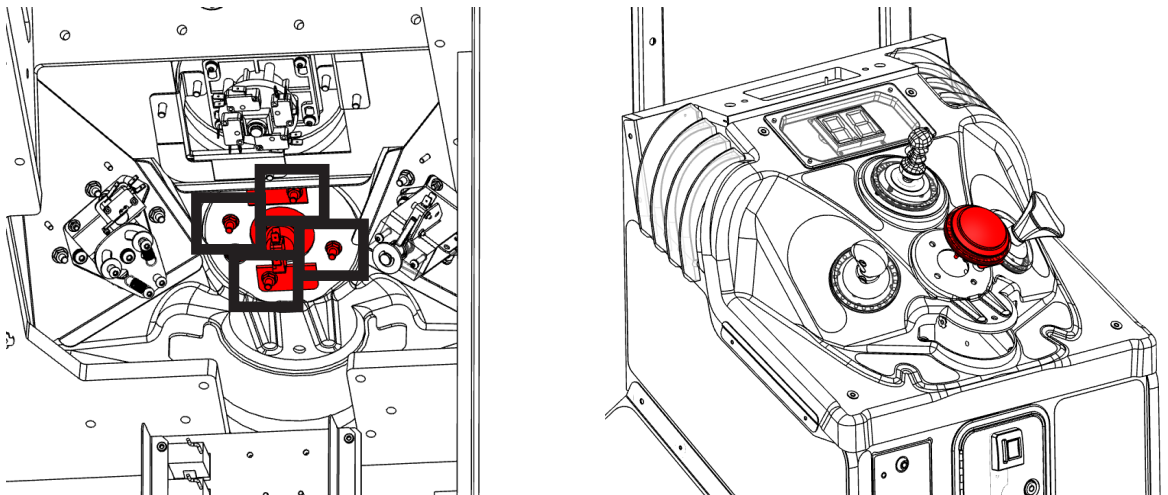

11 COIN HANDLING

Handling the Coin Jam

If the coin is not rejected when the REJECT button is pressed, open the coin chute door and open the selector gate. After removing the jammed coin, put a normal coin in and check to see that the selector correctly functions.

11-1 CLEANING THE COIN SELECTOR

STOP IMPORTANT

- Remove and clean smears by using a soft cloth dipped in water or diluted chemical detergent and then squeezed dry
- Never apply machine oil, etc. to the Coin Selector
- After cleaning the Coin Selector, insert a regular coin in the normal working status and ensure that the selector correctly functions

The Coin Selector should be cleaned once every 3 months.
When cleaning, follow the procedure below:

- 1 Turn the power for the machine OFF. Open the Coin Chute Door
- 2 Remove the Coin Selector from the Coin Chute Door
- 3 Open the gate and dust off by using a soft brush (small soft Paint Brush, etc.)

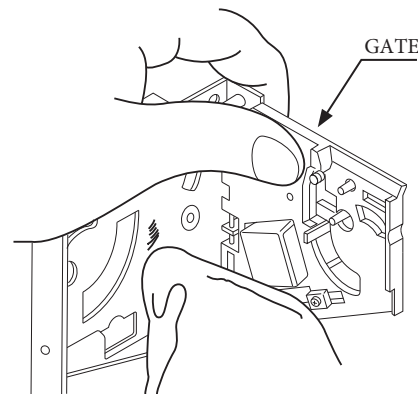

CLEANING THE COIN SELECTOR (MECHANICAL)

- 1 Remove and clean smears by using a soft cloth dipped in water or diluted chemical detergent and then squeezed dry.
- 2 Remove the CRADLE. When removing the retaining ring (E ring) be very careful so as not to bend the rotary shaft.
- 3 Remove stain from the rotary shaft and shaft receiving portions by wiping off with a soft cloth, etc.
- 4 After wiping off as per previous step, further apply a dry cloth to completely dry the Coin Selector.

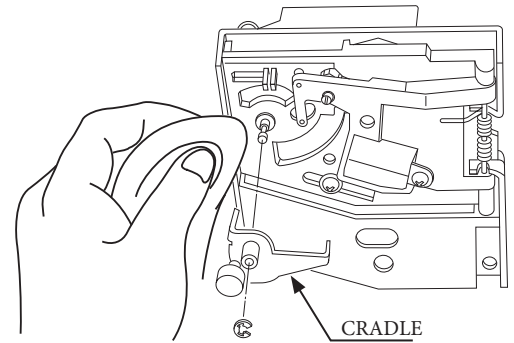

Coin Insertion Test

Once every month, when performing the Coin SW Test, simultaneously check the following:

Does the Coin Meter count satisfactorily?

Does the coin drop into the cashbox correctly?

Is the coin rejected when inserted while keeping the REJECT Button pressed down?

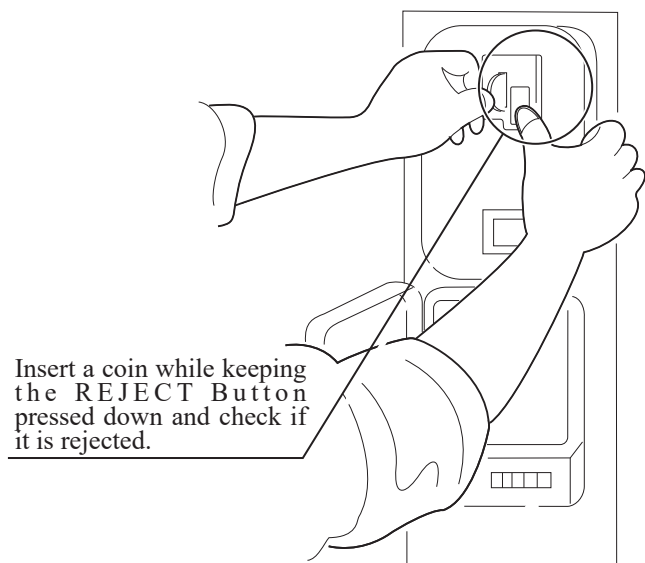

CLEANING THE COIN SELECTOR (SR3 / NRI)

- 1** Remove and clean smears by using a damp soft cloth dipped in water. DO NOT use any diluted chemical detergent or cleansing agent as this will impair the workings of the component.

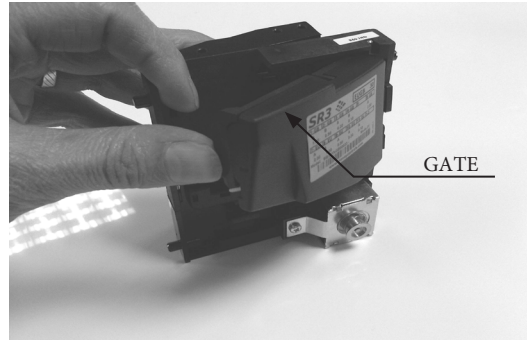

- 2** Open the reject gate to gain access to the rundown path.

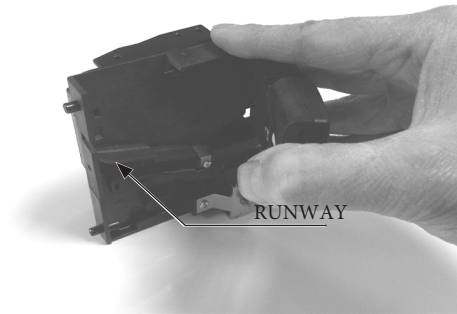

- 3** Remove the dirt and stains from the runway by wiping off with a soft damp cloth.



- 4** After wiping off as per previous step, further apply a dry cloth to completely dry the coin Selector.

11-2 FAULT FINDING

Fault Finding

The following information is presented for customers' guidance in rectifying a fault but does not cover all possible causes.

All acceptors with electronic faults should be returned to an approved service centre for repair.

SYMPTOM	INVESTIGATE	POSSIBLE CAUSE
Acceptor does not work (all coins reject)	Connector	Poor Contact
		Loose Wire
	Power Supply	Not switched on
		Incorrect voltage
		Inadequate current
		Rise time too slow
		Accepter Inhibited
	Inhibit all inputs	Acceptor Inhibited
	Accept gate	Gate not free or dislocated
	Accept channel	Obstruction
	Reject gate	Not fully closed
	LED on rear cover RED	EEPROM chksm error
		SR Sensor fault
Credit opto fault		
Credit sensor blocked		
Reject lever pressed		
LED on rear cover YELLOW	Reinstall power	
Poor Acceptance	Power Supply	Voltage less than 10v (Voltage drops when coil engages)
	Accept gate	Gate jam or dislocated
	Connector	Loose
	Coin rundown	Dirty
	Bank Select	Both banks enabled
Coin stick or jam in acceptor	Accept channel	Acceptor dirty or may have some damage
	Accept gate	
	Reject gate	
A true coin type rejects	Label	Coin not programmed
No accept signal	Connector	Loose or broken wire
	Accept channel	Path dirty or obstructed

11-3 ADJUSTING THE PRICE OF PLAY (EXCEL)

STOP IMPORTANT

- The price of play is determined by the configuration of switches located on either the EXCEL or VTS board. The type of board used is determined by product location. Switch settings for both types of board remain the same

This product comes equipped with a Crane NRI Coin Acceptor. To adjust the price of play ALL CREDIT SETTINGS are adjusted via the EXCEL CREDIT BOARD.

IMPORTANT!

The CREDIT SETTINGS within the SYSTEM TEST MODE must be set to 1 coin 1 credit to allow the CREDIT BOARD to function correctly.

The CREDIT BD has a built in accumulator. This is controlled by 2 DIL Switches. These allow the operator to select the price of play, type of coin acceptor and region.

EXCEL Credit Board

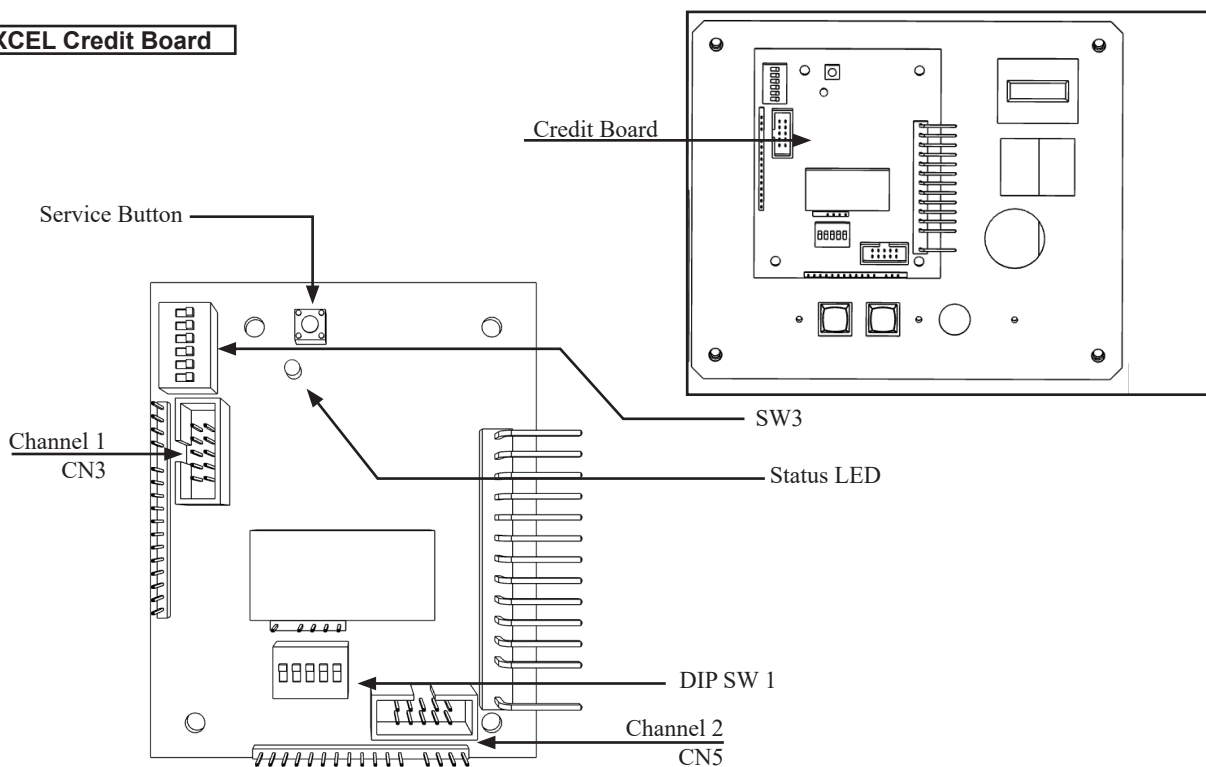

DIL SW3 (Regional Settings)

Adjust these switches to specify the type of Coin Acceptor used and currency.

Default = SW1&SW2 ON - SR3/NRI in parallel mode, Sterling.

SERVICE BUTTON

Provides a SERVICE CREDIT when pressed

Status LED

Flashes when functioning.

CHANNEL 1

To Coin Acceptor (SR3 TYPE.)

DIL SW1 (credit settings)

Adjust to required price of pay.

VOL CONTROL

MAIN VOLUME ADJUSTMENT (FRONT SPEAKERS)

11-4 COIN REGION & PRICE OF PLAY SETTINGS

Country	Setting	Switch 3 Setting						Coin Validator Mode Settings Switch 3											
		SW1	SW2	SW3	SW4	SW5	SW6	Coin Validator Programming						C120/SR3 Only					
							COIN1	COIN2	COIN3	COIN4	COIN5	COIN6	COIN7	COIN8	COIN9	COIN10	COIN11	COIN12	
UK	Coin Controls	OFF	OFF	OFF	OFF		£1	50p new	20p	10p	-	50p old	-	-					
	C220 Parallel	ON	OFF	OFF	OFF		£1	50p new	20p	10p	-	50p old	-	£2					
UK	Coin Controls	ON	OFF	OFF	OFF		£1	50p new	20p	10p	-	£2	-	50p old					
	C220 Binary	OFF	ON	OFF	OFF		£1	50p new	20p	10p	-	£2	-	50p old					
UK	Coin Controls	ON	ON	OFF	OFF		£1	50p new	20p	10p	-	£2	-	50p old					
	Sr3 Parallel	OFF	OFF	ON	OFF		£2	£1	50p new	20p	10p	-	-	50p old					
Euro	Sr3 Parallel	ON	OFF	ON	OFF		€2	€1	50¢	20¢	10¢	-	-	-					
UK	Mars MEMS 111 Parallel	ON	OFF	ON	OFF		£1	£2	20p	10p	50p new	50p old							
UK	NRI Parallel	OFF	ON	ON	OFF		10p	20p	50p	£1	£2	-							
Belgium	Parallel	ON	ON	ON	OFF		-	50Bfr	20Bfr	5Bfr									
Holland	Parallel	OFF	OFF	OFF	ON		-	5NLG	2.5NLG	1NLG									
Austria	Sr3 Parallel	ON	OFF	OFF	ON		20Sch	10Sch	5Sch	1Sch									
Spain	Coin Controls	OFF	ON	OFF	ON		500Pta	200Pta	100Pta	50Pta	25Pta	200Pt old	50Pta old	25Pta old					
	C220 Binary	ON	ON	OFF	ON		500Pta	200Pta	100Pta	50Pta	25Pta	200Pt old	50Pta old	200Pta old					
Spain	Sr3/NRI Parallel	ON	ON	OFF	ON														
Spain	Coin Controls	OFF	OFF	ON	ON		100Pta	50Pta	-	25Pta new	-	50Pta old	-	25Pta old					
	C220 Parallel	ON	OFF	ON	ON		200Es	100Es	50Es	-	-	-	-	-					
Portugal Euro	Parallel	ON	OFF	ON	ON		€1	50¢	50Es	-	-	-	-	-					
	TBA				OFF		TBA												
	Channels					ON	TBA												
							OFF	Direct Mode											
							ON	2 channel Mode											

Note: These switch settings are under constant review and may change due to world currency updates.

Set SW 1 according to the option settings found in the relevant Price of Play Settings Table on the following pages.

Set SW 3 on the VTS /Excel board as shown in the table above corresponding to the country required.

Please Note
The credit board automatically sets the validator for parallel and binary operation through an output on pin 8 of the 17 way pinstrip. For the feature to work it is necessary for the validator interconnecting cable to include at wire at this position

	PRICE OF PLAY	BONUS	DIL SWITCH 1				
			1	2	3	4	5
1	0.10	-	OFF	OFF	OFF	OFF	OFF
2	0.10	0.50 = 6 credits	ON	OFF	OFF	OFF	OFF
3	0.20	-	OFF	ON	OFF	OFF	OFF
4	0.20	0.50 = 3 credits	ON	ON	OFF	OFF	OFF
5	0.30	-	OFF	OFF	ON	OFF	OFF
6	0.30	1.00 = 4 credits	ON	OFF	ON	OFF	OFF
7	0.30	0.50 = 2 credits	OFF	ON	ON	OFF	OFF
8	0.30	1.00 = 3 credits	ON	ON	ON	OFF	OFF
9	0.40	-	OFF	OFF	OFF	ON	OFF
10	0.40	1.00 = 3 credits	ON	OFF	OFF	ON	OFF
11	0.50	-	OFF	ON	OFF	ON	OFF
12	0.50	1.00 = 3 credits	ON	ON	OFF	ON	OFF
13	0.50	2.00 = 5 credits	OFF	OFF	ON	ON	OFF
14	0.60	-	ON	OFF	ON	ON	OFF
15	0.60	1.00 = 2 credits	OFF	ON	ON	ON	OFF
16	0.80	-	ON	ON	ON	ON	OFF
17	0.80	1.50 = 2 credits	OFF	OFF	OFF	OFF	ON
18	1.00	-	ON	OFF	OFF	OFF	ON
19	1.00	2.00 = 3 credits	OFF	ON	OFF	OFF	ON
20	1.00	4.00 = 5 credits	ON	ON	OFF	OFF	ON
21	1.50	-	OFF	OFF	ON	OFF	ON
22	1.50	2.00 = 2 credits	ON	OFF	ON	OFF	ON
23	2.00	-	OFF	ON	ON	OFF	ON
24	2.00	5.00 = 3 credits	ON	ON	ON	OFF	ON
25	3.00	-	OFF	OFF	OFF	ON	ON
26	3.00	5.00 = 2 credits	ON	OFF	OFF	ON	ON
27	5.00	-	OFF	ON	OFF	ON	ON
28	5.00	10.00 = 3 credits	ON	ON	OFF	ON	ON
29	7.50	-	OFF	OFF	ON	ON	ON
30	7.55	10.00 = 2 credits	ON	OFF	ON	ON	ON
31	10.00	-	OFF	ON	ON	ON	ON
32		FREE PLAY	ON	ON	ON	ON	ON

The price of play is controlled by DIL switches 1 to 5 of a bank of 8, located on the EXCEL CREDIT BD.

Default values are in **BOLD**

11-5 PRICE OF PLAY QUICK START - USA

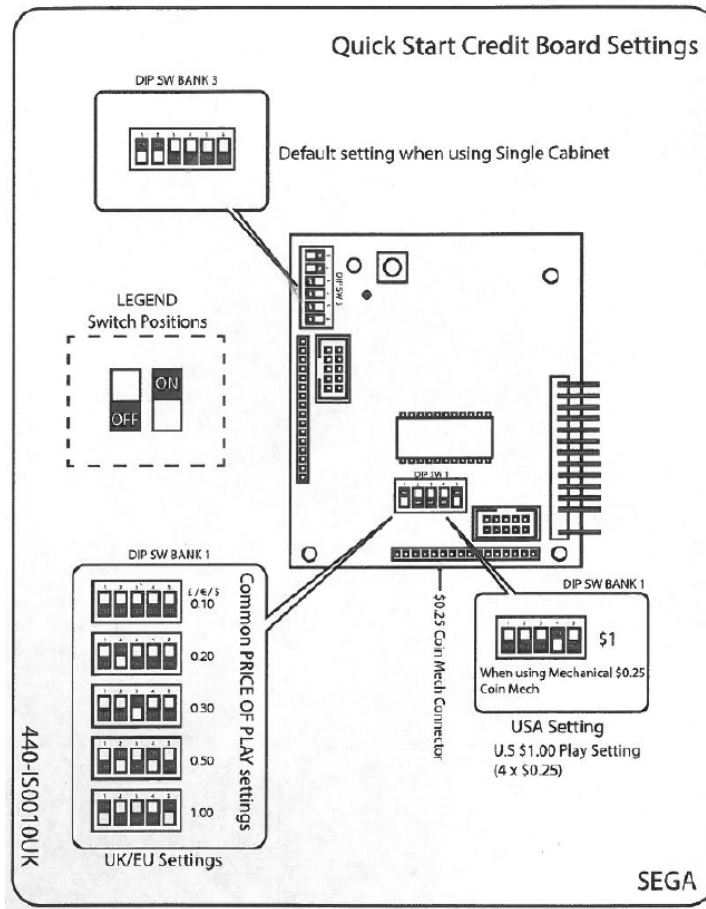

DIL SWITCH BANK ONE (5 way SW1)						
Item	Price	SW1	SW2	SW3	SW4	SW5
1	25cent	OFF	OFF	OFF	OFF	OFF
3	50cent	OFF	ON	OFF	OFF	OFF
5	75cent	OFF	OFF	ON	OFF	OFF
9	\$1.00	OFF	OFF	OFF	ON	OFF
16	\$2.00	ON	ON	ON	ON	OFF
DIL SWITCH BANK TWO (6 way SW3)						
Type	SW1	SW2	SW3	SW4	SW5	SW6
USA	OFF	OFF	OFF	OFF	OFF	OFF

12 LAMPS AND LIGHTING

⚠ WARNING

- When working with the product, be sure to turn the power off. Working with the power on may cause an electric shock or short circuit
- You may get burned by a hot fluorescent lamp or other lamps. Pay full attention to the lamps when performing the work
- Be sure to use lamps of the designated rating. Using lamps of undesignated rating can cause a fire or malfunctioning
- There is the danger of short circuits or smoke generation due to deterioration of insulation in lighting fixtures resulting from age deterioration. Check for anomalies such as the following: Does it smell like something is burning? Is there socket discoloration? Are any lamps being replaced frequently? Do lamps not go on properly?

⚠ CAUTION

The Coin Door Lamp utilises a 12v 1.2w Wedge Bulb. It is important that you replace this bulb or any other bulb of that of the same voltage and rating. Failing to observe this caution may result in PCB failure or possible fire hazard

12-1 COIN DOOR LAMP

Step 1. Open the Coin Door and locate the Lamp Housing directly behind the Coin Insert Bezel

Step 2. Hold the Lamp Housing firmly between your index finger and thumb and gently pull upwards. Do not try to remove the Lamp Housing whilst holding the bulb as the bulb may break causing injury

Step 3. Once the Lamp Housing has been removed, carefully hold the bulb between your fingers and pull the Lamp Housing away

Do not twist either bulb or Lamp Housing while removing the bulb as this may cause damage to both bulb and/or Housing.

Step 4. Simply push-fit a replacement bulb of the same type and follow these steps in reverse to refit

Lamp Housing

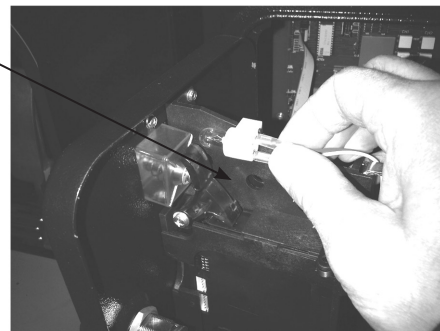

Type: Wedge Bulb - 12v, 1.2w

12-2 CABINET LED LIST

12

LAMPS AND LIGHTING

Related Assembly	Lighting Part # + Description	QTY
BI-0500UK ASSY BILLBOARD	BI-6001UK ASSY BB TOP	2
	BI-6002UK ASSY BB SHORT	1
	BI-6003UK ASSY BB MID	1
BI-1000UK ASSY MAIN CABINET	EP1421 LED 12V RED RS 541-40722	1
	BI-6004UK ASSY LED FLOOR	1
BI-1550/1550UK ASSY LED CLUSTER L/R	SAI-6201-0200UK ASSY RGB LED SH	4
BI-2100UK ASSY CTRL CABINET	838-0039UK PCBA 2X7 SEG LED	1
BI-2200UK ASSY CTRL PULL IT	390-2512-106RGB RING LED 106MM RGB M10624	1
BI-2300UK ASSY CTRL TWIST IT	390-2512-106RGB RING LED 106MM RGB M10624	1
BI-2400UK ASSY CTRL FLICK IT	390-2512-106RGB RING LED 106MM RGB M10624	1
BI-2600UK ASSY CTRL PUSH IT	390-2512-106RGB RING LED 106MM RGB M10624	1
BI-3000UK ASSY MAIN DISPLAY	390-2805-3232P5 LED MATRIX P5-221-32*32	4
	838-0052UK PCBA - LED MATRIX RGB	4
BI-3100UK ASSY BONUS BOX	390-2805-3232P5 LED MATRIX P5-221-32*32	2

12-3 CABINET LED LOCATIONS

BI-2200UK - ASSY PULL IT

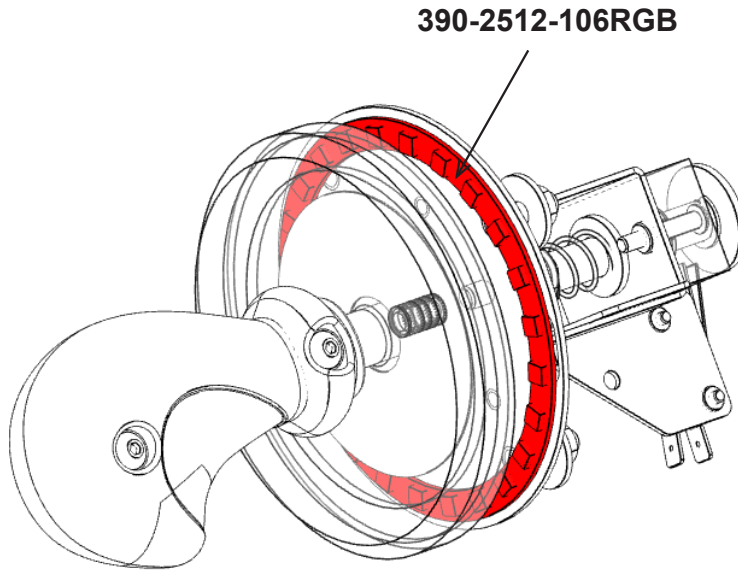

BI-2300UK - ASSY FLICK IT

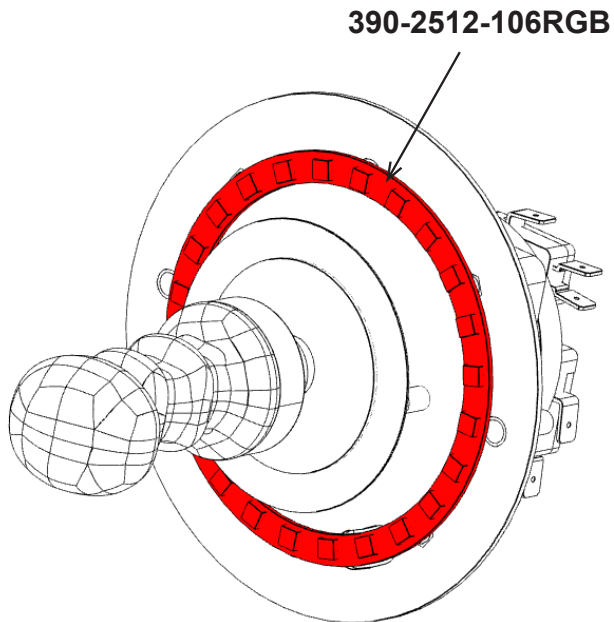

BI-2400UK - ASSY TWIST IT

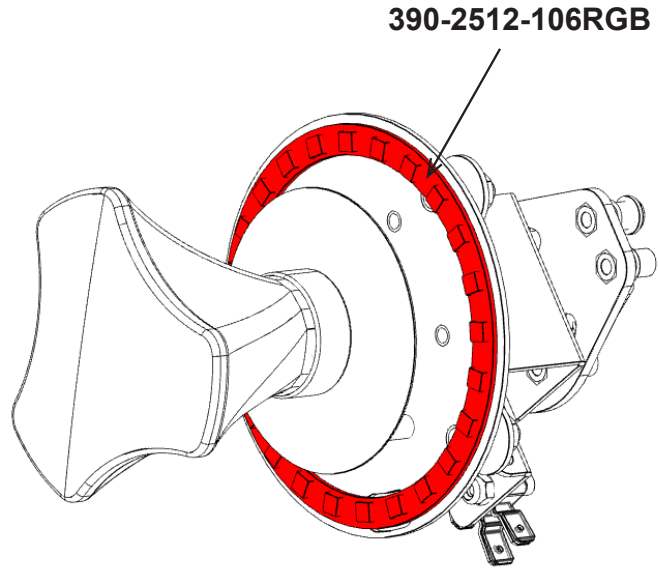

BI-2600UK - ASSY CTRL PUSH IT

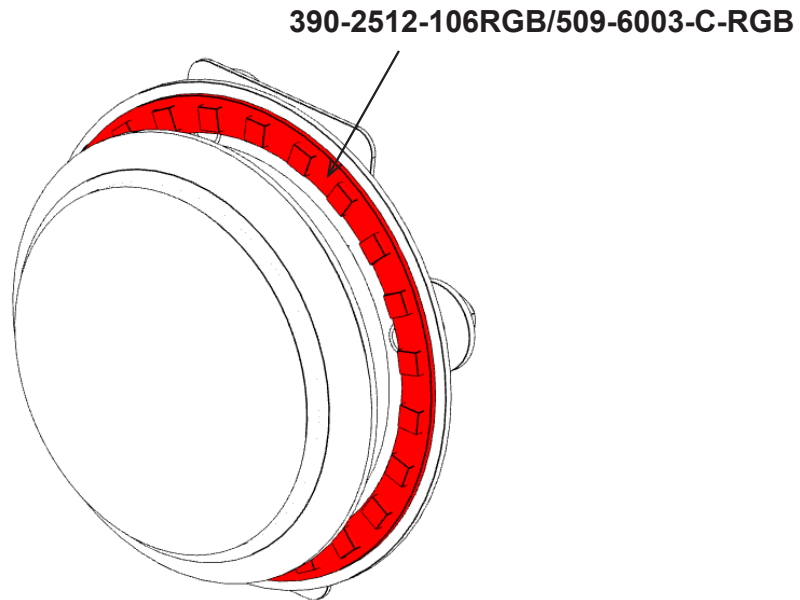

BI-1000UK + 2100UK - ASSY MAIN CAB + CONTROL PANEL

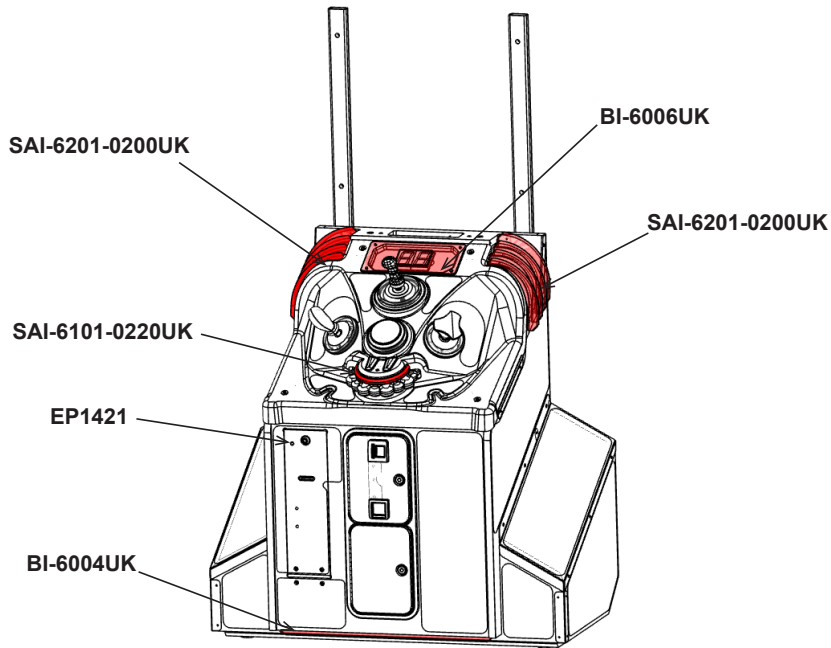

BI-3000UK - ASSY MAIN DISPLAY

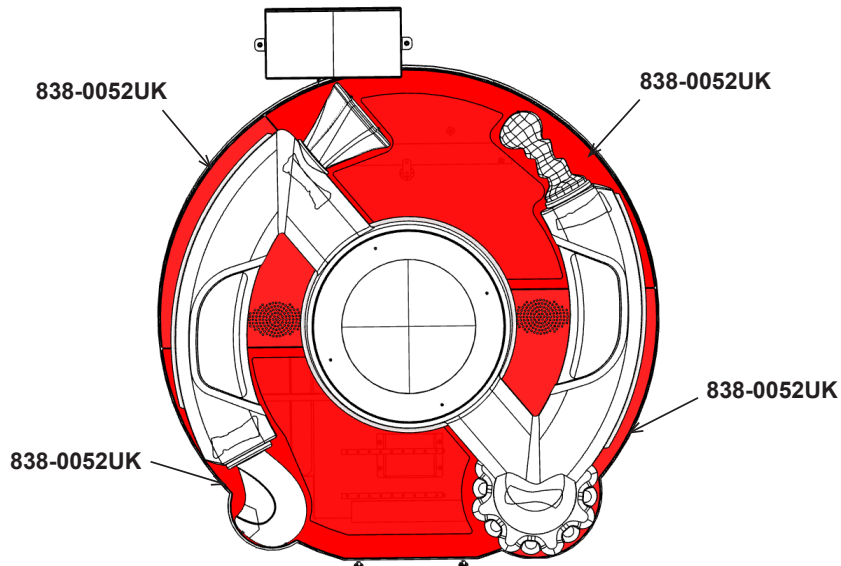

BI-3000UK - ASSY MAIN DISPLAY

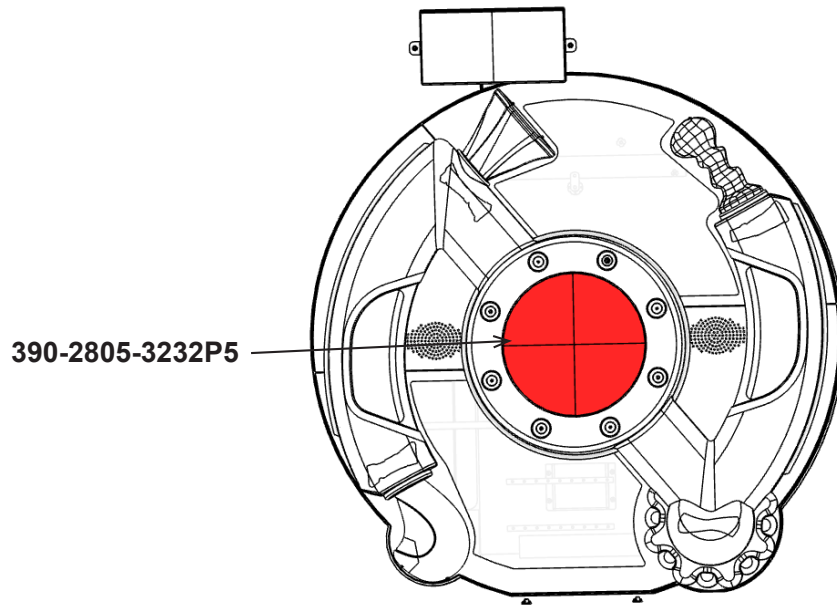

BI-3100UK - ASSY BONUS BOX

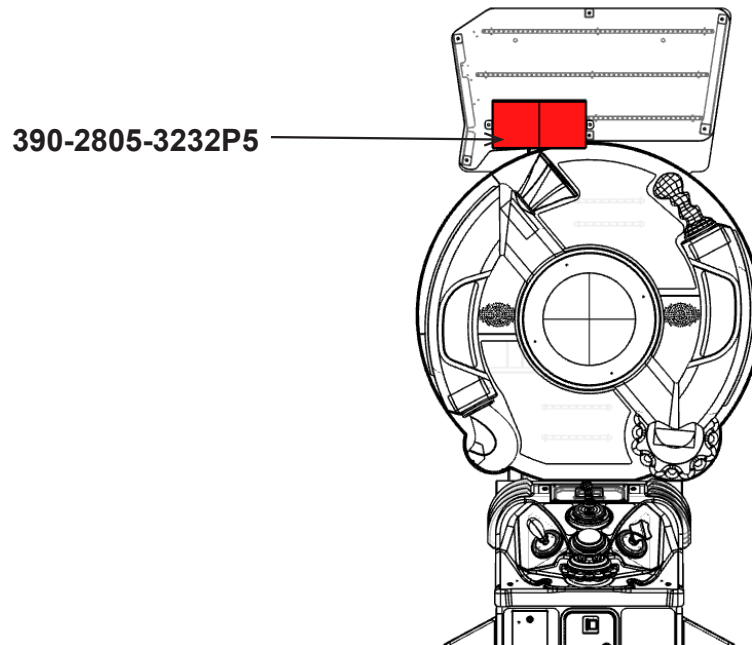

BI-0500UK - ASSY BILLBOARD

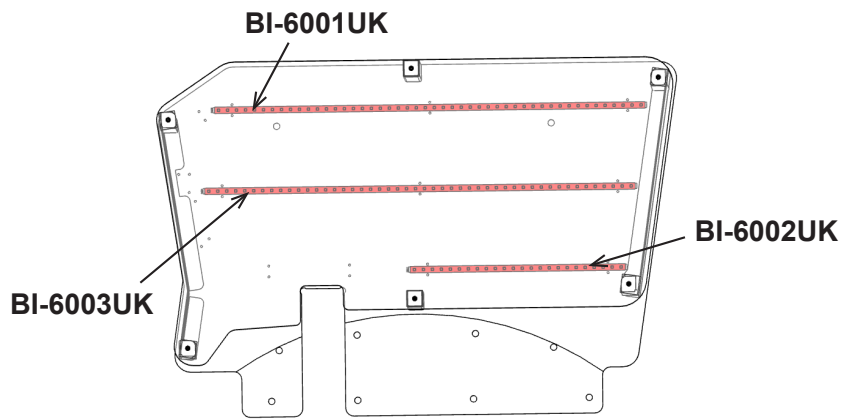

13 PERIODIC INSPECTION

The items listed below require periodic check and maintenance to retain the performance of this machine and to ensure safe business operation.

When handling the controller, the player will be in direct contact with it. In order to always allow the player to enjoy the game, be sure to clean it regularly.

WARNING

- Every 6 months check to see if power cords are damaged, the plug is securely inserted, no dust has accumulated between the socket outlet and the power plug, etc. Using the product with accumulated dust in the interior may cause fire or electric shock
- Never use a water jet, etc. to clean the inside or outside of the Cabinet. If wetness occurs for any reason, do not use the product until it has completely dried
- Once a year, request the office shown on this Manual or the dealer from whom the product was originally purchased to perform the internal cleaning. Using the product with accumulated dust in the interior may cause fire or other accidents
- Note that you are liable for the cost of cleaning the interior parts
- There is the danger of accidents involving electrical shorts circuits or fire caused by factors such as the deterioration of insulation in electrical and electronic equipment over time. Check that there are no abnormalities such as odours from burning

PERIODIC INSPECTION TABLE

PERIOD	ITEM	DESCRIPTION	REFERENCE
As appropriate	Cabinet Surface	Cleaning	As Below
	Control Unit Surface		
Daily	Cabinet	Confirm Adjusters Contact Floor	Chapter 6
Monthly	Cabinet	Speaker Volume	Chapter 9
	Controller Units	Check Each Input Device	Chapter 9
		Check Each Output Device	Chapter 9
	LEDs	LED Inspection	Chapter 12
	Coin Selector	Coin Path Inspection	Chapter 11
Coin Insertion Test		Chapter 11	
Every 3 Months	Coin Selector	Cleaning	Chapter 11
1 Year	Game BD	Cleaning	Chapter 15
	Power Cables	Inspection / Cleaning	As Above
	Cabinet Interior	Cleaning	As Above

Cleaning the Cabinet Surfaces

When the Cabinet surfaces are badly soiled, remove stains with a soft cloth dipped in water or diluted (with water) chemical detergent and squeezed dry. To avoid damaging surface finish, do not use solvents such as thinner, benzine, etc. other than ethyl alcohol, or abrasives, bleaching agent and chemical dustcloth.

Some general-purpose household, kitchen and furniture cleaning products may contain strong solvents that degrade plastic components, coatings, and print. Before using any cleaning product, read the product's cautionary notes carefully and test the product first on a small area that is not highly visible.



14 TROUBLESHOOTING

14-1 TROUBLESHOOTING (WHEN NO ERROR MESSAGE IS SHOWN)

WARNING

- This work should be performed by site maintenance personnel or other skilled professionals. Work performed by non-technical personnel can cause a severe accident such as an electric shock. If there are no site maintenance personnel or other skilled professionals available, turn off the power immediately and contact the office given in this Manual or from point of purchase
- When working with the product, be sure to turn the power off. Working with the power on may cause and electric shock or short circuit accident
- In order to prevent electric shock and short circuit, be sure to turn power off before performing work
- Be careful so as not to damage wirings. Damaged wiring can cause electric shock or short circuit
- After removing the cause of the functioning of the Circuit Protector, reinstate the Circuit Protector. Depending on the cause of the functioning, using the Circuit Protector as is without removing the cause can cause generation of heat and fire hazard
- In the event that a problem cannot be resolved by employing the procedures listed in this Manual, be sure to request service from the office shown in this Manual or the dealer from whom the product was originally purchased. Attempts to employ procedures other than those specified in this Manual can cause electrical shock, shorting, or fire
- In the event of a problem that is not described here, be sure to contact the office shown on this Manual or the dealer from whom the product was originally purchased. Careless attempts at repair can result in electrical shock, shorting, or fire

STOP IMPORTANT

- If an error message is displayed, identify the cause and without delay take the appropriate countermeasures. Leaving the error unaddresses could result in a breakdown
- If a problem occurs, first inspect the connection of any wiring connectors
- Static electricity from your body may damage some electronic devices on the IC board. Before handling any IC board, touch a grounded metallic surface so that static electricity is discharged

If a problem occurs, first check to make sure that the wiring connectors are properly connected.

TROUBLESHOOTING TABLE

PROBLEM	CAUSE	COUNTERMEASURE
With Main Switch ON there is no activation	Power is not supplied	Insert power lead all the way into outlet
	Supply voltage is not correct	Adjust supply voltage to correct value
	Red2 Board is not receiving power	Check power connectors to Red2 Board (Chapter 15)
No Sound	Volume not properly adjusted	Adjust volume
	Poor connection of connectors	Check connections of amp
	Board, amp or speaker fault	Run speaker test to check (Chapter 9)
Switch and Volume pot input does not work	Poor connection of connectors	Check the connection to Game Bd
Button/Controller input does not work	Switch fault	Replace switch (Chapter 10)
Button/Controller Unit does not light	Lamp failure	Replace lamp (Chapter 12)
Controller Unit(s) do not work properly	Improper controller adjustment	Configure using Test mode (Chapter 9)
Tickets are not vended	Tickets exhausted	Replace tickets (Chapter 6-6)
	Ticket vend jammed	Remove obstruction

Note:

The table above shows a list of possible failures and a brief solutions. If problems persist further or there are additional issues which may not be listed here. Please contact you point of sale or the SEGA Service Department on the contact numbers shown at the end of this Manual.

15 GAME BOARD

WARNING

- When working with the product, be sure to turn the power off. Working with the power on may cause an electric shock or short circuit
- Be careful not to damage the wires. Damaged wires may cause an electric shock, short circuit or present a risk of fire
- Do not use this product with connectors other than those that were connected and used with the Game Board at the time of shipping. Do not carelessly connect wires to connectors that were not used at the time of shipping, as this may cause overheating, smoke or fire damage

CAUTION

In this product, setting changes are made during the test mode. The Game Board need not be operated. Use the Game Board, etc. as is with the same setting made at the time of shipment so as not to cause electrical damage or malfunction

STOP IMPORTANT

Static electricity from your body may damage some electronics devices on the IC board. Before handling the IC board, touch a grounded metallic surface so that the static electricity can be discharged

15-1 GAME BOARD - HANDLING PRECAUTIONS

WARNING

- To prevent electric shock or IC Board malfunctioning, be sure to turn off the power for the Cabinet when installing or removing the IC Board
- Extraneous matter such as dust on the IC Board can cause the IC Board to generate heat and result in a fire due to short circuit, etc. Ensure the IC Board surfaces are always kept clean
- Always follow the usage conditions from SEGA as well as the usage conditions for the Cabinet you are using for RED 2. Failure to do so may cause an overheating and fire

STOP

IMPORTANT

- Be sure to connect the IC Board and connectors completely. Insufficient insertion can damage IC Board, etc.
- For the IC Board circuit inspection, only the use of Logic Tester is permitted. The use of ordinary testers is not permitted as these can damage the IC Board
- Do not subject the IC Board to static electricity when installing the IC Board in the cabinet or when connecting wire harness connectors to the IC Board
- When soldering buttons, etc. to the wire harnesses, be sure to remove the wire harnesses from the IC Board so as not to subject the IC Board to heat
- Some parts are the ones designed and manufactured not specifically for this product. The manufacturers may discontinue, or change the specifications of, such general-purpose parts. If this is the case, SEGA cannot repair or replace a failed product whether or not a warranty period has expired

15-2 GAME BOARD - LOCATION & REMOVAL

WARNING

- When returning the Game Board after making repairs or replacements, make sure that there are no errors in the connection of connectors. Erroneous connections can lead to electrical shock, short circuits or fires
- When connecting a connector, check the direction carefully. Connectors must be connected in only one direction. If indiscriminate loads are applied in making connections, the connector or its terminal fixtures could be damaged, resulting in electrical shock, short circuits or fires

The machine is fitted with a Game Board Unit and several other Ancillary Boards which are fitted inside the rear of the Cabinet. Each machine contains its own CPU. Only qualified Personnel should attempt to Service these Units and before gaining access to the machine, it should be isolated from the mains supply.

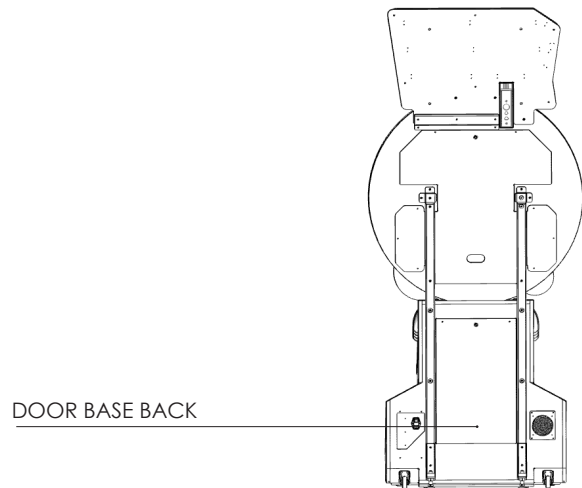

There is only one access point to the GAME BD which is through the DOOR BASE BACK located at the rear of the Cabinet. Unlock the DOOR BASE BACK, the GAME BD is located directly behind the door.

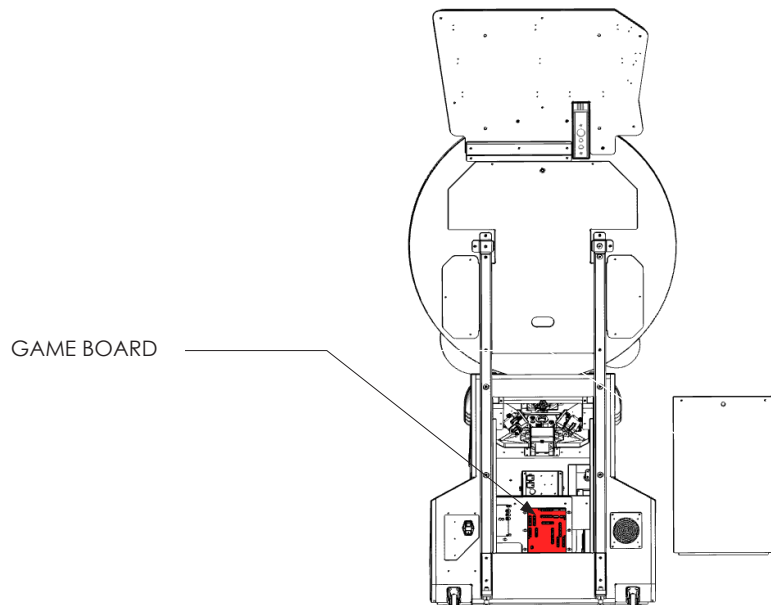

15-3 GAME BOARD - INTRODUCTION

The RED-2 board is an arcade game controller capable of driving two simple cabinets at once. It contains a powerful ARM processor running at 100MHz and many peripherals, including:

- SD card for game software and data logging
- Audio amplifier for sound effects
- On-board EEPROM (4k x 8bits) for game logging
- 256 x LED array output (Multiplexed as 32 c.c. sinks x 8 rows)
- 16 x 2 Line LCD display interface with controlled backlight
- 2 x 7-segment 'Credit' LED display driver
- 4 x 7-segment 'Credit' LED display driver
- 4 x 6-wire stepper motor drives
- 4 x high current (1 Amp) switch outputs
- 32 x general purpose 500mA digital outputs (e.g. LED strip drives)
- 24 x general purpose digital inputs
- 8 x buffered analogue inputs, with 5V outputs for pots
- 1 x 100baseT Ethernet port
- 1 x 500Mbit/s CAN port
- 1 x USB Port
- 2 x Dedicated Motor Drives
- 1 x RS232 port
- Controlled by a 100MHz 32-bit processor with an ARM M3 core
- JTAG port, bootstrap programming port.

To achieve the high channel count of inputs and outputs of the RED-2 board, most peripherals to the microcontroller are implemented via I/O expanders driven over I2C busses.

Critical inputs and outputs (credit, vend, opto. sensors etc.) have dedicated connections directly to the processor.

15-4 GAME BOARD - PARTS DETAIL

LAYOUT

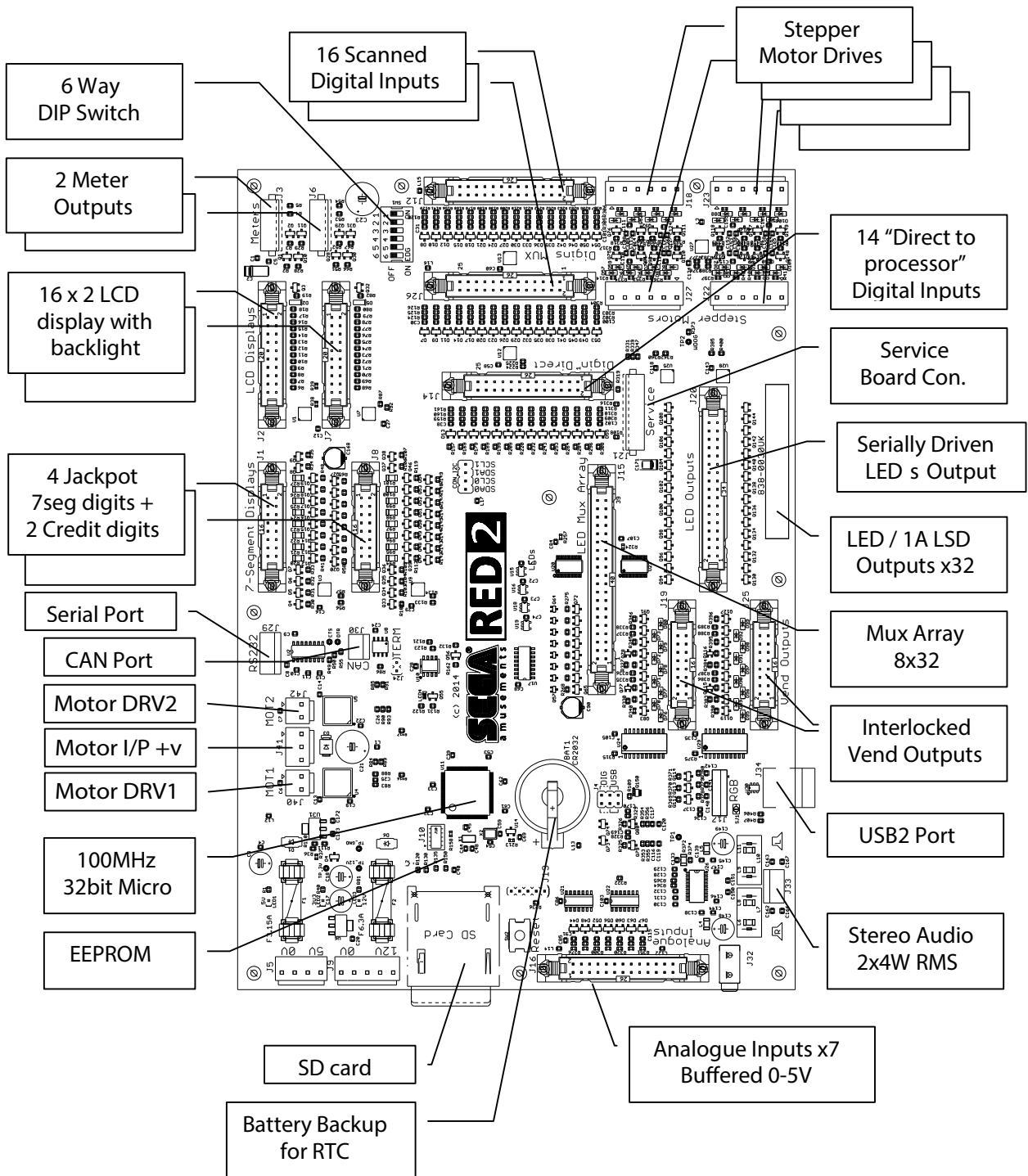

The machine is fitted with Game Board Unit (RED2) and several other Ancillary Boards which are fitted inside the rear of the Cabinet. Each machine contains the its own CPU.. Only qualified Personnel should attempt to Service these Units and before gaining access to the machine, it should be isolated from the mains supply

⚠ WARNING

- When connecting the connector, check the orientation and type carefully and connect securely. The connector must be connected in the proper direction and type. If it is connected in the wrong direction or indiscriminately at an incline, or connected wrong connector, so that a load is applied, the connector or its terminal pins could break, causing a short circuit or fire
- Do not connect components to any connector that are not designated by SEGA. Connecting unspecified components could cause an accident such as an electric shock or fire

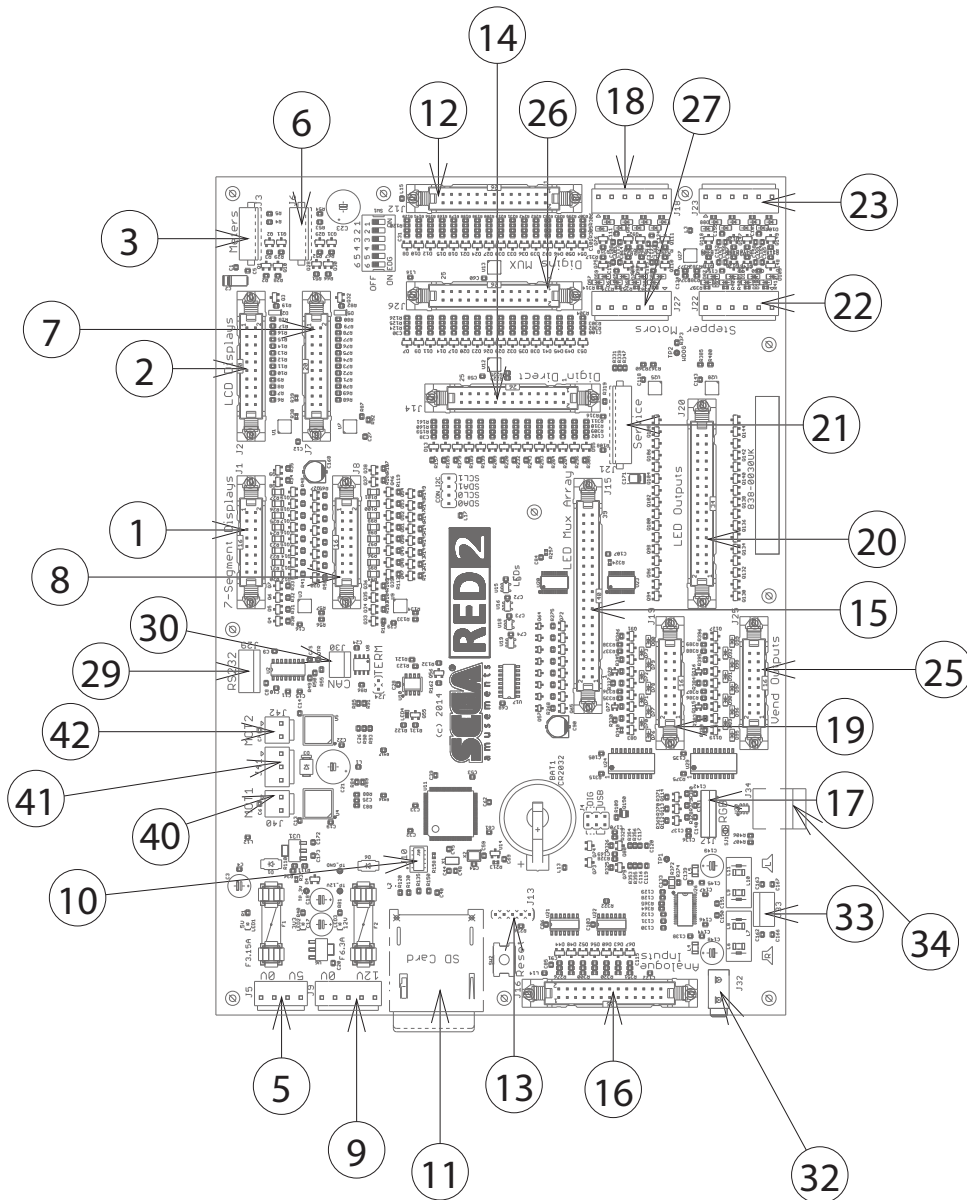

1 7 - Segment LED Display

LOCATION	TYPE
J1	16W JST RA TYPE

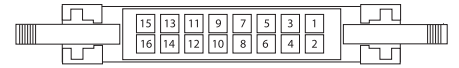

2 LCD Display

LOCATION	TYPE
J2	20W JST RA TYPE

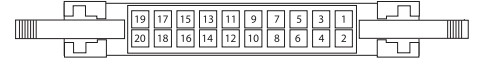

3 Counters / Meters

LOCATION	TYPE
J3	6W JST NH

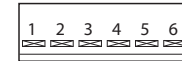

4 Ethernet

LOCATION	TYPE
J4	RJ45

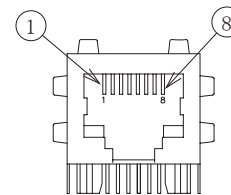

5 Power

LOCATION	TYPE
J5	4W JST VH



6 Counters / Meters

LOCATION	TYPE
J6	6W JST NH

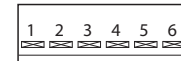

7 LCD Display

LOCATION	TYPE
J7	20W JST RA TYPE



8 7 - Segment LED Display

LOCATION	TYPE
J8	16W JST RA TYPE



9 Power

LOCATION	TYPE
J9	5W JST VH

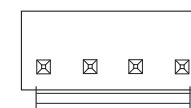

10 NOT USED

LOCATION	TYPE
J10	N/A

11 SD CARD READER FAT16

LOCATION	TYPE
J11	4W JST VH

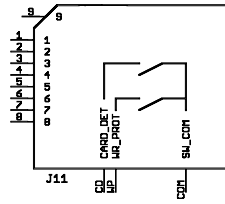

12 DIGITAL INPUTS MUX0-15

LOCATION	TYPE
J12	26W JST RA TYPE

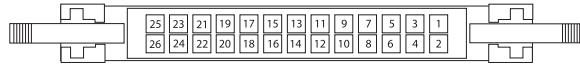

13 BOOT LOADER - DEV PURPOSES ONLY

LOCATION	TYPE
J13	5W SIL HDR

14 DIRECT DIGITAL INPUTS

LOCATION	TYPE
J14	26W JST RA TYPE

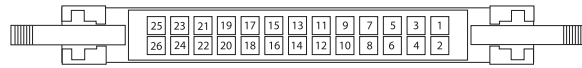

15 LED MUX ARRAY

LOCATION	TYPE
J15	40W JST RA TYPE



16 ANALOGUE INPUTS

LOCATION	TYPE
J16	26W JST RA TYPE

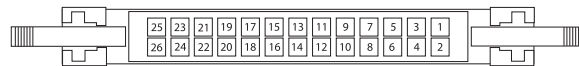

17 RGB

LOCATION	TYPE
J17	6W JST PH K S



18 MOTOR PORT C

LOCATION	TYPE
J18	6W JST VH - VNR-6N

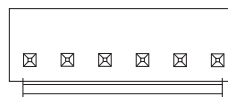

19 7 - Segment LED Display

LOCATION	TYPE
J19	16W JST RA TYPE



20 Cabint and Switch LED Drives

LOCATION	TYPE
J20	34W JST RA TYPE



21 SERVICE

LOCATION	TYPE
J21	9W JST NH

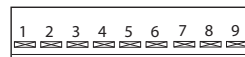

22 MOTOR PORT A

LOCATION	TYPE
J22	6W JST VH - VNR-6N



23 MOTOR PORT B

LOCATION	TYPE
J23	6W JST VH - VNR-6N



25 VEND OUTPUTS

LOCATION	TYPE
J25	16W JST RA TYPE



26 DIGITAL INPUTS MUX16-31

LOCATION	TYPE
J26	26W JST RA TYPE



27 MOTOR PORT D

LOCATION	TYPE
J27	6W JST VH - VNR-6N



28 COMMS RS232

LOCATION	TYPE
J28	9W D Type Female

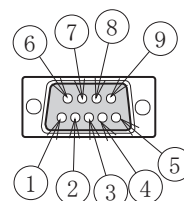

29 COMMS RS232

LOCATION	TYPE
J29	5W JST NH



30 CAN PORT

LOCATION	TYPE
J30	3W JST NH



31 CAN PORT

LOCATION	TYPE
J31	9W D Type Female

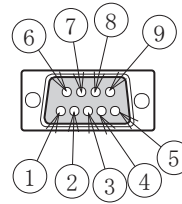

32 AUDIO BRIDGE

LOCATION	TYPE
J32	3W JST NH



33 AUDIO

LOCATION	TYPE
J33	4W JST NH



34 DIP SWITCH

LOCATION	TYPE
J34	USB2 PORT

40 MOTOR 1

LOCATION	TYPE
J40	3W JST VH

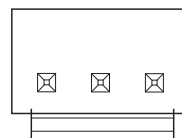

41 MOTOR SUPPLY I/P

LOCATION	TYPE
J41	2W JST VH

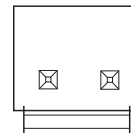

42 MOTOR 2

LOCATION	TYPE
J42	3W JST VH

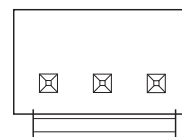

PLEASE REFER TO THE SCHEMATIC DIAGRAMS FOR DETAILED PINOUTS OF EACH CONNECTOR.

44 DIP SWITCH

LOCATION	TYPE
SW1	6W DIP SW

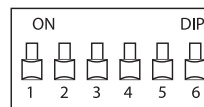

Usage differs depending on game software. Set accordingly to the instructions given in this service manual under the section of TEST and DISPLAY DATA - DIP SWITCH SETTINGS

The factory settings when a game board (RedOne) is purchased as a stand alone unit

No. 1	No. 2	No.3	No. 4	No. 5	No. 6
OFF	OFF	OFF	OFF	OFF	OFF

15-5 REPLACING THE BUTTON BATTERY

WARNING

- Make sure you do not damage the printed board and wires. Such damage can lead to electric shock, short circuit and fire hazard
- To prevent overheating, explosion, or fire:
 - Do not recharge, disassemble, heat, incinerate, or short the battery
 - Do not allow the battery to come into direct contact with metallic objects or other batteries
- To preserve the battery, wrap it in tape or other insulating material
- Follow local regulations when disposing of the battery. Improper disposal can damage the environment
- Even the site maintenance personnel or other qualified professionals must not perform replacement operations for parts not described in this Manual. In the event that such work is required either contact the office listed in this Manual or first confirm the procedure with the place or office of purchase. Failure to do so may lead to electric shock or short circuit
- Do not turn on the power with current carrying parts exposed. Doing so could result in electric shock or short circuit

STOP

IMPORTANT

- The batteries in RED 2 can be used for approximately 4 years of standard usage. If the battery appears to require replacement sooner than 4 years, it is more likely that an error has occurred with some other part of the board. Rather than exchanging the battery requesting repair of the board itself may be more appropriate
- Static electricity from your body may damage some electronics devices on the IC board. Before handling the IC board, touch a grounded metallic surface so that the static electricity can be discharged
- To avoid risk of malfunction and damage:
 - Make sure the positive and negative ends are aligned correctly
 - Use only batteries approved for use with this unit

15-6 DIP SWITCH SETTINGS

Bop It! - DIL Switch Settings

The settings below are Standard Factory default settings.

15

GAME BOARD

SW	STATE	FUNCTION
1	ON	*HQ AUDIO PCB - MUST BE ON
	OFF	SD Audio
2	ON	SHOW MODE - Ticket Payout OFF
	OFF	SITE MODE - Ticket Payout ON
3	ON	CEC MODE ON
	OFF	CEC MODE OFF
4	ON	NOT USED (N/U)
	OFF	N/U
5	ON	* WATCHDOG - MUST BE ON
	OFF	
6	ON	N/U
	OFF	N/U

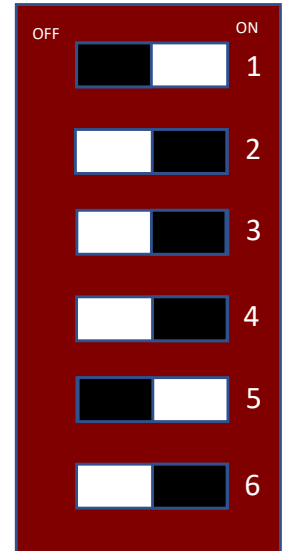

16 DESIGN RELATED PARTS

For the warning display stickers, refer to Section 1.

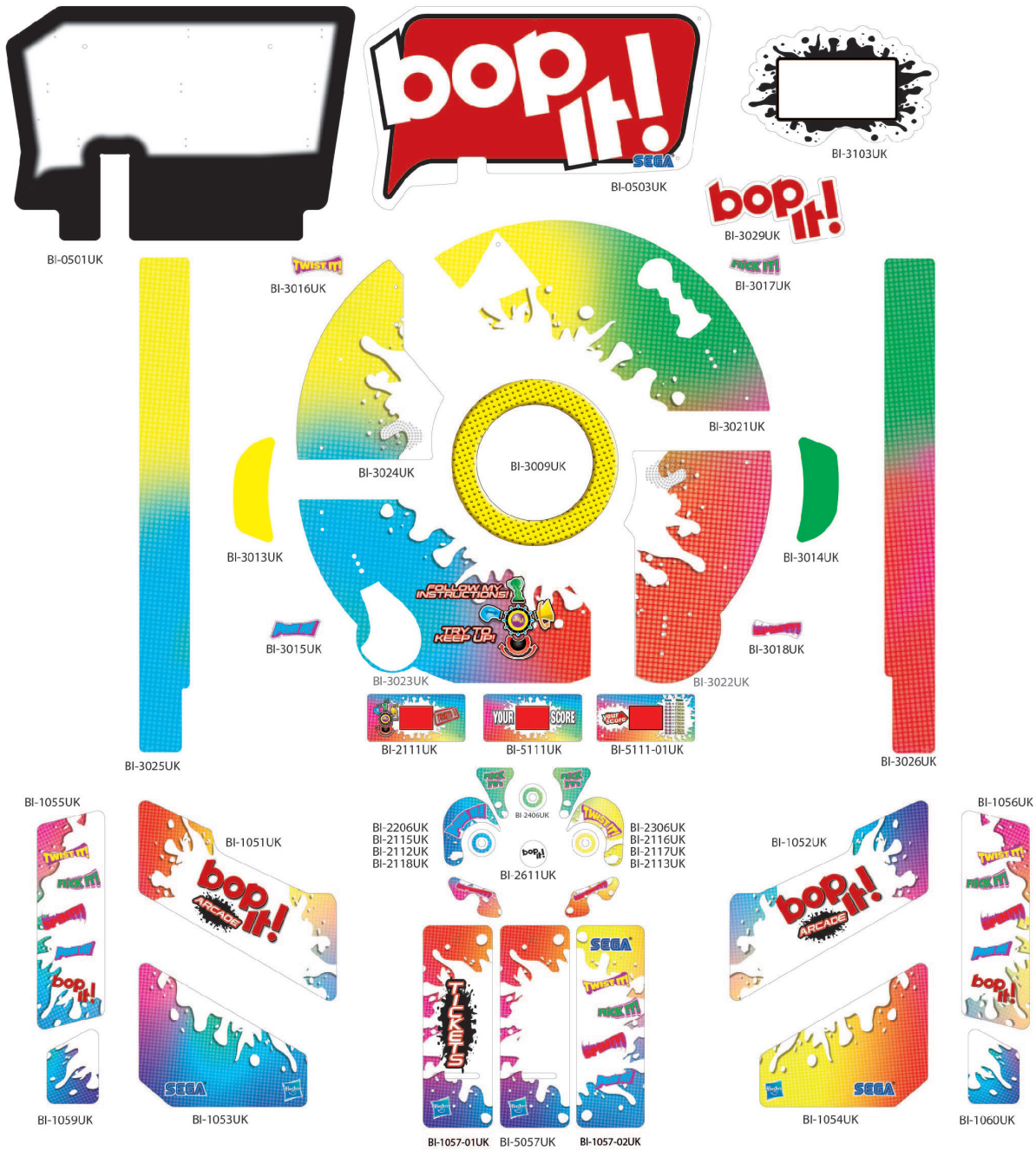

17 PARTS LIST

BOP IT STRUCTURE FLOW

TOP ASSY BOP IT ARCADE

BI-0000UK
TOP ASSY BOP IT ARCADE

*
BI-1000UK
ASSY MAIN CABI

**
BI-1080UK
ASSY AC UNIT

BI-0320UK
ASSY SW UNIT

BI-0325UK
ASSY LCD 2675575 MIDAS

BI-1500UK
ASSY LED CLUSTER L

BI-1550UK
ASSY LED CLUSTER R

BI-2100UK
ASSY CTRL PANEL

BI-2600UK
ASSY CTRL PUSH IT

BI-2200UK
ASSY CTRL PULL IT

BI-2220UK
ASSY SHAFT PULL IT

BI-2300UK
ASSY CTRL TWIST IT

BI-2320UK
ASSY SHAFT TWIST IT

BI-2400UK
ASSY CTRL FLICK IT

BI-2420UK
ASSY SHAFT FLICK IT

BI-2500UK
ASSY CTRL SPIN IT

BI-2520UK
ASSY MOULD SPIN IT

BI-4000UK
ASSY ELEC

BI-4100UK
ASSY PSU

SND-1340UK
ASSY FAN

BI-INST
ASSY INST KIT BI

BI-0500UK
ASSY BILLBOARD

BI-3000UK
ASSY MAIN DISPLAY

BI-3010UK
ASSY BOP IT

BI-0100UK
ASSY STABILIZER BACK

BI-3100UK
ASSY BONUS BOX

Please note: The location of all artwork can be found in Chapter 16 of this manual.

① TOP ASSY BOP IT ARCADE (BI-0000UK)

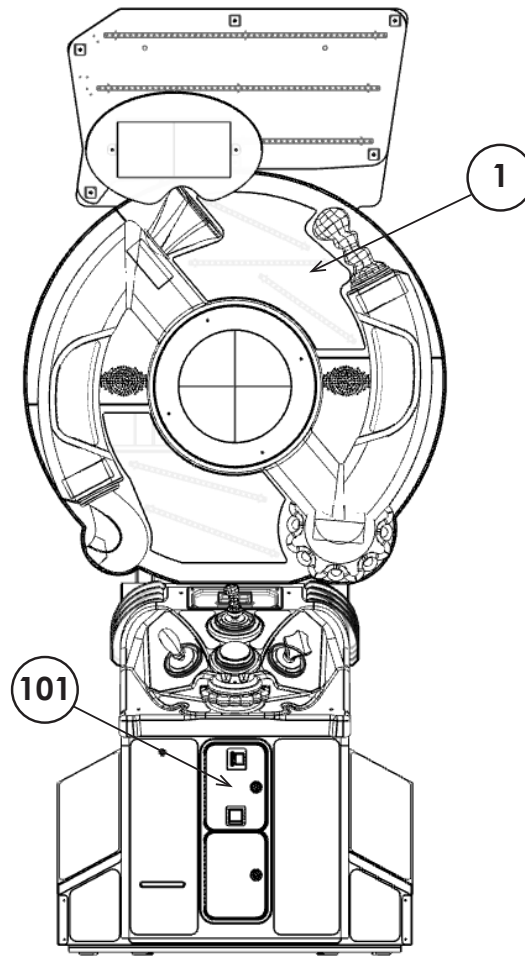

ITEM NO	PART NO	DESCRIPTION	QTY
*1	BI-1000UK	ASSY MAIN CABI	1
*20	421-7988-91UK	STICKER SERIAL NUMBER UK	1
*101	220-5740-01W	DFMD W/UNIV CRADLE/CBOX ENC/LOCKS WHITE	1
*103	OS1247	ALUMINIUM STICKY CLIP ASK-3 475-198	3
*401	BI-INST	ASSY INST KIT BI	1
*403	PK0557	SLEEVE BI	1
*404	PK0551	PALLET BI	1
*405	PK0552	BOX BI MAIN DISPLAY	1
*406	420-0040UK	MANUAL BI	1
*407	PK0559	BAR STRAP BI	1

Please note: The location of all labels can be found in Chapter 1 of this manual.

② ASSY STABILIZER BACK (BI-0100UK)

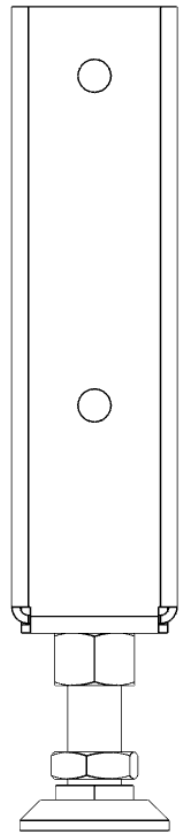
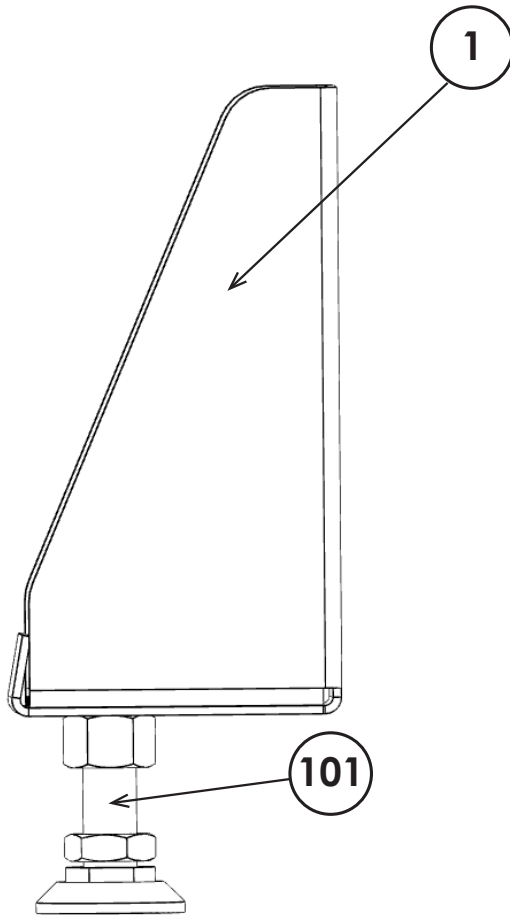

ITEM NO	PART NO	DESCRIPTION	QTY
*1	BI-0101UK	BRKT STABILZER BACK	1
***101	601-5699UK-01	LEG ADJUSTER M16X100 1L/NUT	1

③ ASSY LCD 2675575 MIDAS (BI-0325UK)

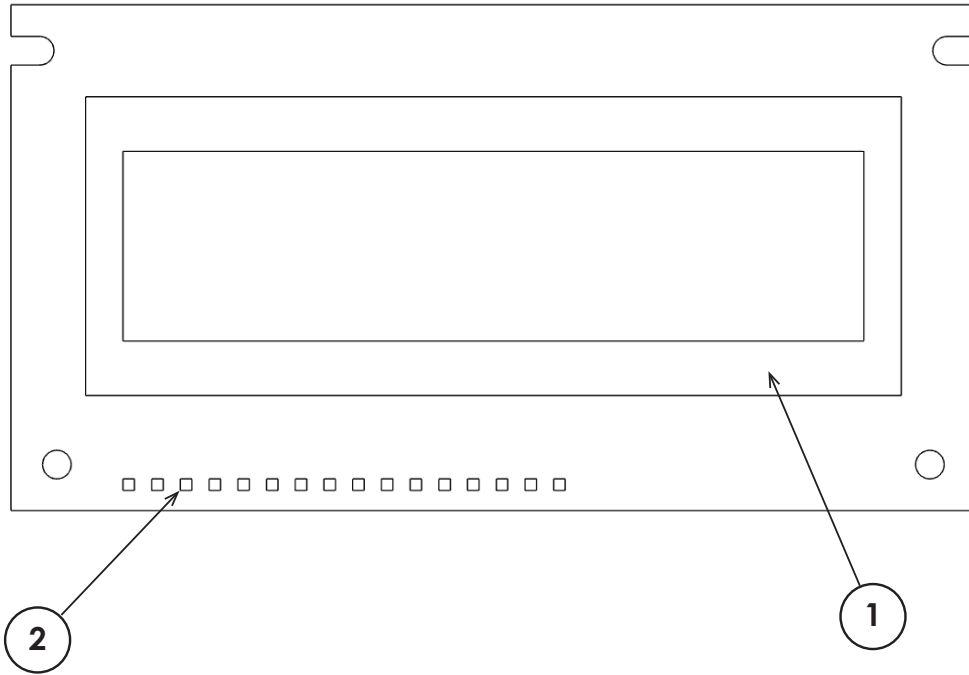

ITEM NO	PART NO	DESCRIPTION	QTY
****1	EP1494	LCD 2x16 2675575 MIDAS	1
****2	EP1516	HEADER KK 16P 6410 RS670-1291	1

④ ASSY SW UNIT (BI-0320UK)

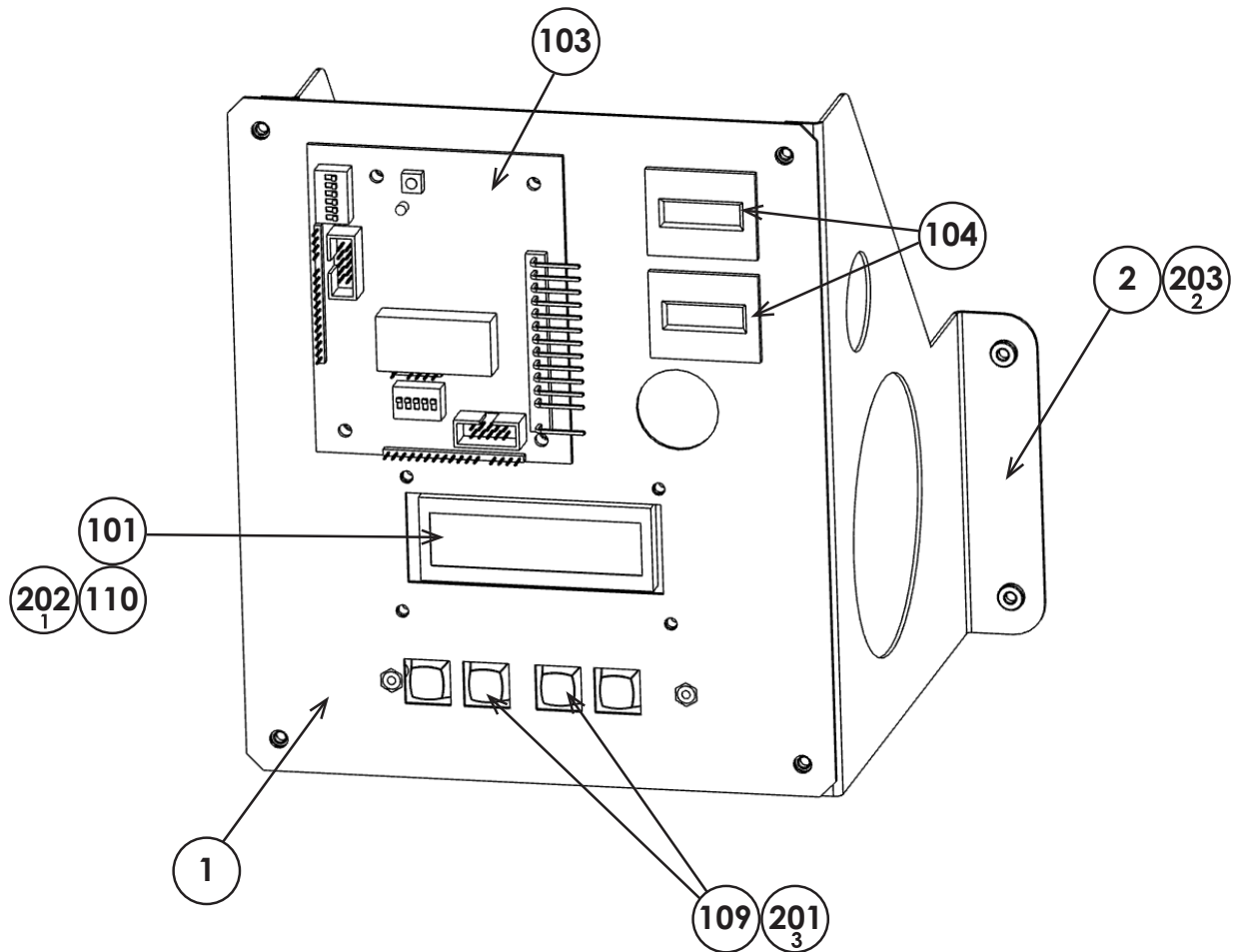

ITEM NO	PART NO	DESCRIPTION	QTY
***1	BI-0321UK	SW BRKT DOUBLE METER	1
***2	BI-0322UK	BRKT MTG SW UNIT	2
***101	BI-0325UK	ASSY LCD 2675575 MIDAS	1
***102	280-L00706-PM	STANDOFF 6.4MM HOLE PM	4
***103	EP1380-01	CREDIT BOARD EXCEL	1
***104	220-5643UK	COIN METER SMALL 12V	2
***105	OS1247	ALUMINIUM STICKY CLIP ASK-3	1
***107	OS1098	CRIMP BELL END SMALL	4
***108	601-0460	CABLE TIE NYLON 100MM	2
***109	838-0058UK	PCBA DIGITAL SW VOL BD	1
***110	280-0005UK	HOLDER EDGE PCB SCREW MNT 6MM	4
***201	000-P00308-W	M3X8 MSCR PAN W/FS PAS	3
***202	012-P03506-F	N6X1/4" S/TAP FLG PAS	4
***203	029-B00412	M4X12 SKT BH PAS	4
***301	BI-60015UK	WH COIN HAND	1
***302	BI-60022UK	WH TICKET MECH	1

5 ASSY BILLBOARD (BI-0500UK)

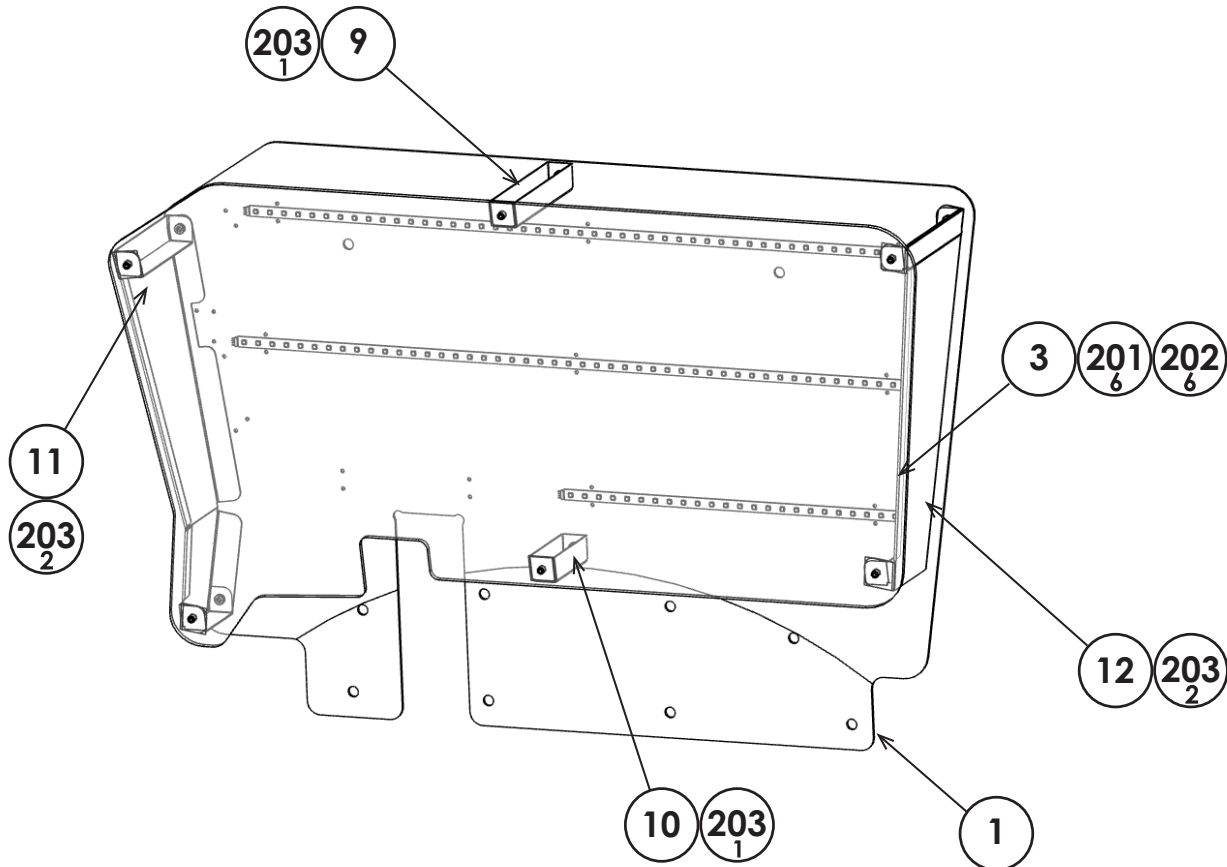

ITEM NO	PART NO	DESCRIPTION	QTY
***1	BI-0501UK	BOARD BACK BILLBOARD	1
***3	BI-0503UK	PANEL HEADER BILLBOARD	1
***9	BI-0509UK	STRUT SUPP HEADER TOP MID	1
***10	BI-0510UK	STRUT SUPP HEADER BTM MID	1
***11	BI-0511UK	BRKT ENDCAP L	1
***12	BI-0512UK	BRKT ENDCAP R	1
***101	601-0460	CABLE TIE NYLON 100MM	15
***201	029-B00412	M4X12 SKT BH PAS	6
***202	068-441616	M4 WSHR 16OD FLT PAS	6
***203	029-B00616	M6X16 SKT BH PAS	6
***301	BI-6001UK	ASSY BB TOP	2
***302	BI-6002UK	ASSY BB SHORT	1
***303	BI-60023UK	WH BILLBOARD LED	1
***304	BI-6003UK	ASSY BB MID	1

⑥ ASSY MAIN CABINET (BI-1000UK)

(1/3)

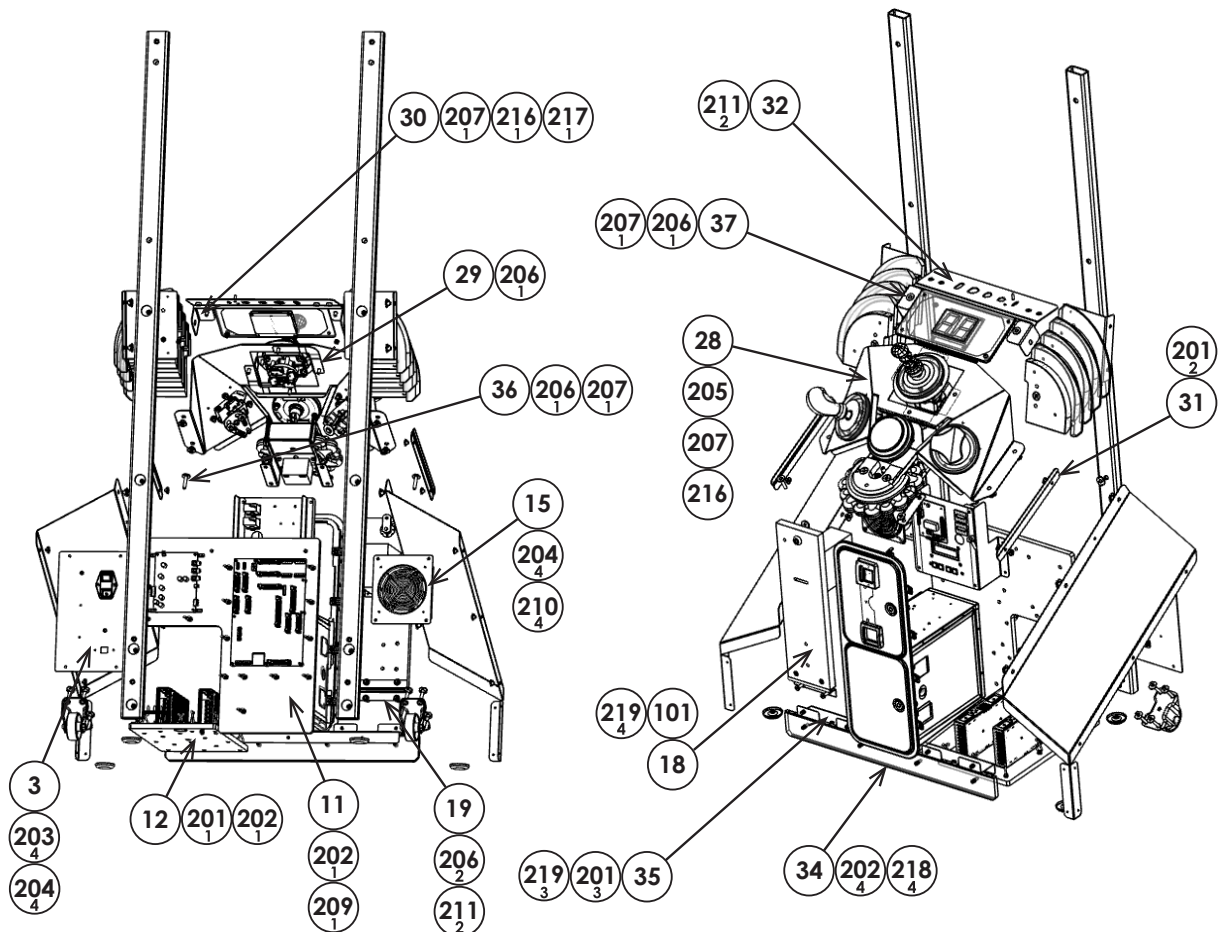
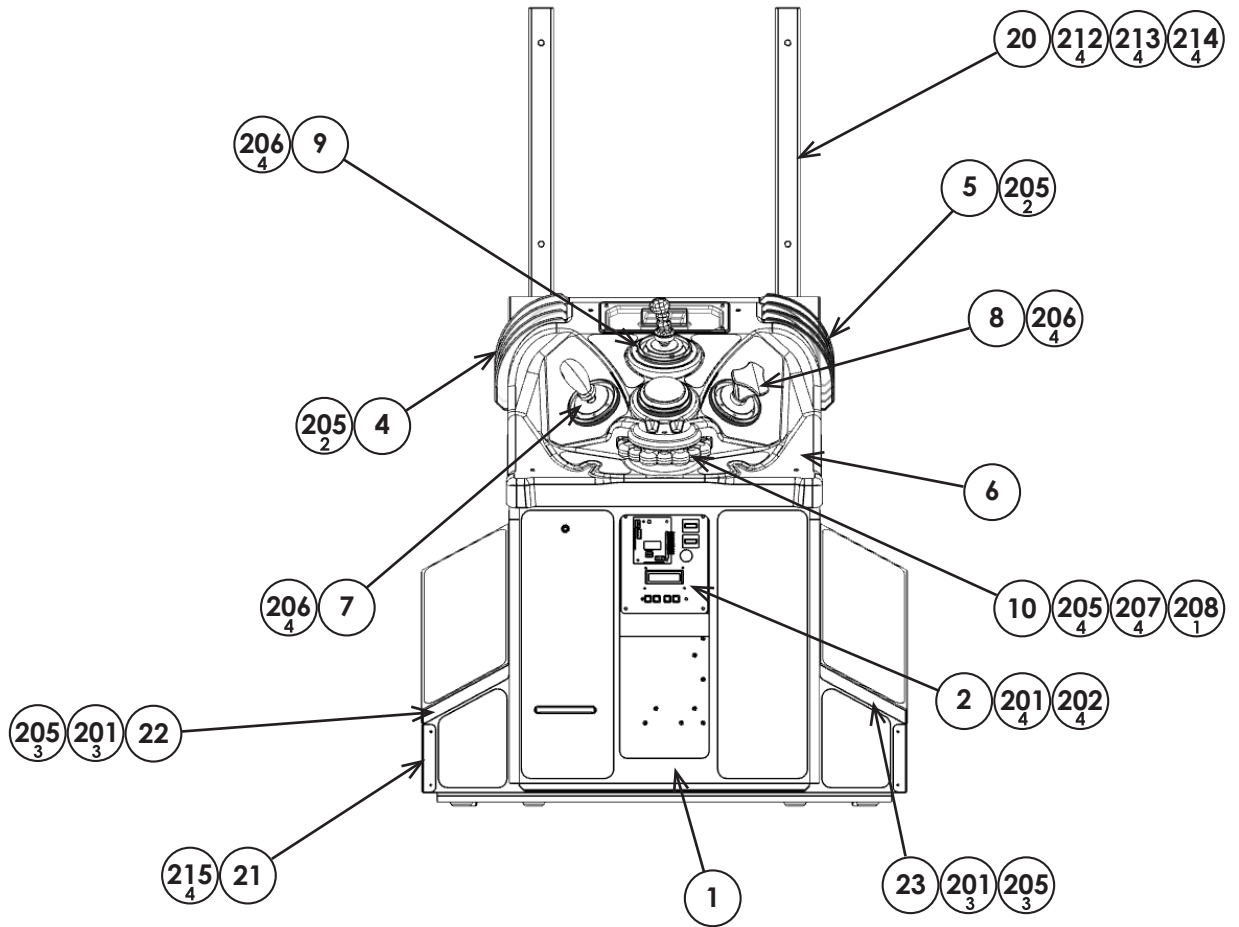

⑥ ASSY MAIN CABINET (BI-1000UK)

(2/3)

ITEM NO	PART NO	DESCRIPTION	QTY
**1	BI-1002UK	ASSY BASE CABI	1
**2	BI-0320UK	ASSY SW UNIT	1
**3	BI-1080UK	ASSY AC UNIT	1
**4	BI-1500UK	ASSY LED CLUSTER L	1
**5	BI-1550UK	ASSY LED CLUSTER R	1
**6	BI-2100UK	ASSY CTRL PANEL	1
**7	BI-2200UK	ASSY CTRL PULL IT	1
**8	BI-2300UK	ASSY CTRL TWIST IT	1
**9	BI-2400UK	ASSY CTRL FLICK IT	1
**10	BI-2500UK	ASSY CTRL SPIN IT	1
**11	BI-4000UK	ASSY ELEC	1
**12	BI-4100UK	ASSY PSU	1
**15	SND-1340UK	ASSY FAN	1
**18	PG-1106UK	HOLDER TICKET	1
**19	PG-1107UK	BRKT RETAIN TICKET HOLDER	1
**20	BI-1003UK	STRUT MAIN DISPLAY SUPP	2
**21	BI-1004UK	BRKT CORNER PROTECT	2
**22	BI-1005UK	COVER MAIN CABI LWR L	1
**23	BI-1006UK	COVER MAIN CABI LWR R	1
**28	BI-1021UK	BRKT CTRL PNL SUPP MAIN	1
**29	BI-1022UK	BRKT FLICK IT SUPP	2
**30	BI-1023UK	BRKT CTRL PNL SUPP TOP	2
**31	BI-1024UK	BRKT COVER CTRL PNL SIDE	2
**32	BI-1025UK	PLATE JOINT PNL MTG	1
**34	BI-1031UK	PLATE LIGHT CABI FRONT EDGE	1
**35	BI-1032UK	BRKT MTG LIGHT CABI FRONT EDGE	1
**36	BI-1033-01UK	STUD CAPPED LONG	2
**37	BI-1033-02UK	STUD CAPPED SHORT	2
**38	BI-1034UK	COVER ASSY PSU	1
**101	220-0001-01UK	TICKET VEND UNIT TD-963CR	1
**102	EP1420	SW MICRO LEVER RS706-4281	1
**103	EP1421	LED 12V RED RS 541-4072	1
**104	280-A01264-WX	ROUTER TWIST D12 SO6.4 WOOD XL	29
**105	280-A02064-WX	ROUTER TWIST D20 SO6.4 WOOD XL	7

⑥ ASSY MAIN CABINET (BI-1000UK)

(3/3)

**201	029-B00425	M4X25 SKT BH PAS	18
**202	068-441616	M4 WSHR 16OD FLT PAS	10
**203	029-B00425-0B	M4X25 SKT BH BLK	4
**204	068-441616-0B	M4 WSHR 16OD FLT BLK	4
**205	029-B00625	M6X25 SKT BH PAS	18
**206	050-F00600	M6 NUT FLG SER PAS	22
**207	068-652216	M6 WSHR 22OD FLT PAS	16
**208	029-B00616	M6X16 SKT BH PAS	1
**209	029-B00440	M4X40 SKT BH PAS	1
**210	029-B00412-0B	M4X12 SKT BH BLK	4
**211	020-F00630	M6X30 SKT CSK PAS	4
**212	029-B00850-0B	M8X50 SKT BH BLK	8
**213	060-S00800-0B	M8 WSHR SPR BLK	8
**214	068-852216-0B	M8 WSHR 22OD FLT BLK	8
**215	012-P03512-F	N6X1/2" S/TAP FLG PAS	10
**216	060-S00600	M6 WSHR SPR PAS	6
**217	029-B00612	M6X12 SKT BH PAS	2
**218	029-B00420	M4X20 SKT BH PAS	4
**219	029-B00412	M4X12 SKT BH PAS	8
**220	020-000316-0Z	M3X16 SKT CAP 0Z	2
**221	050-F00400	M4 NUT FLG SER PAS	6
**222	029-B00630	M6X30 SKT BH PAS	2
**301	BI-60005UK	WH CONT PNL EXT	1
**302	BI-60017UK	WH CNTRL TO UPRIGHT	1
**303	BI-60026UK	WH POWER AUDIO BD	1
**304	600-9120-44K	WH EARTH 120MM M4 M4	3
**305	600-9080-44K	WH EARTH 800MM M4 M4	2
**306	600-9050-44K	WH EARTH 500MM M4 M4	1
**307	BI-6004UK	ASSY LED FLOOR	1

7 ASSY AC UNIT (BI-1080UK)

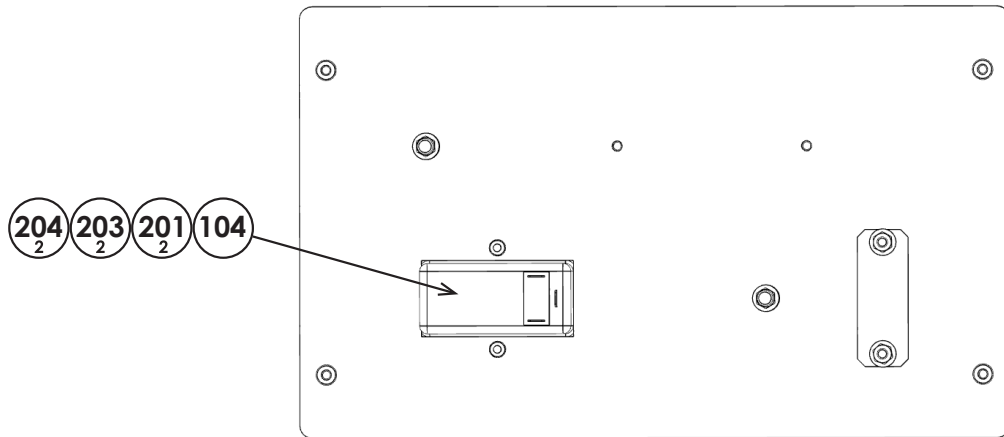
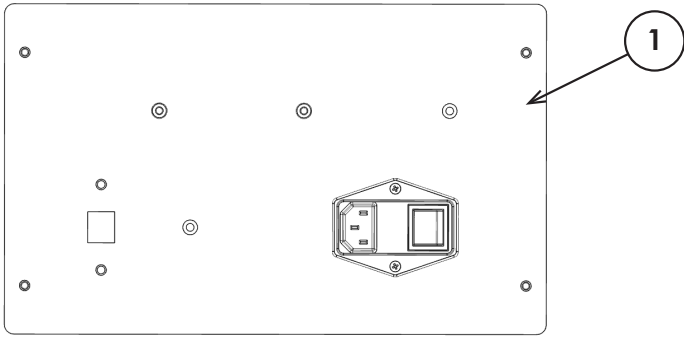

ITEM NO	PART NO	DESCRIPTION	QTY
**1	HP-1081UK	PLATE AC	1
**104	EP1389	FILTER IEC FUSED SW IP0642H2 DELTRON	1
**105	310-5029-D508	HEAT SHRINK SLEEVING 50.8DIA	8
**201	029-B00412	M4X12 SKT BH PAS	2
**202	050-F00400	M4 NUT FLG SER PAS	2
**203	060-F00400	M4 WSHR FORM A FLT PAS	2
**204	060-S00400	M4 WSHR SPR PAS	2
**301	SAI-60008UK	WH AC IN IEC FILTER UNIT	1

⑧ ASSY LED CLUSTER L (BI-1500UK)

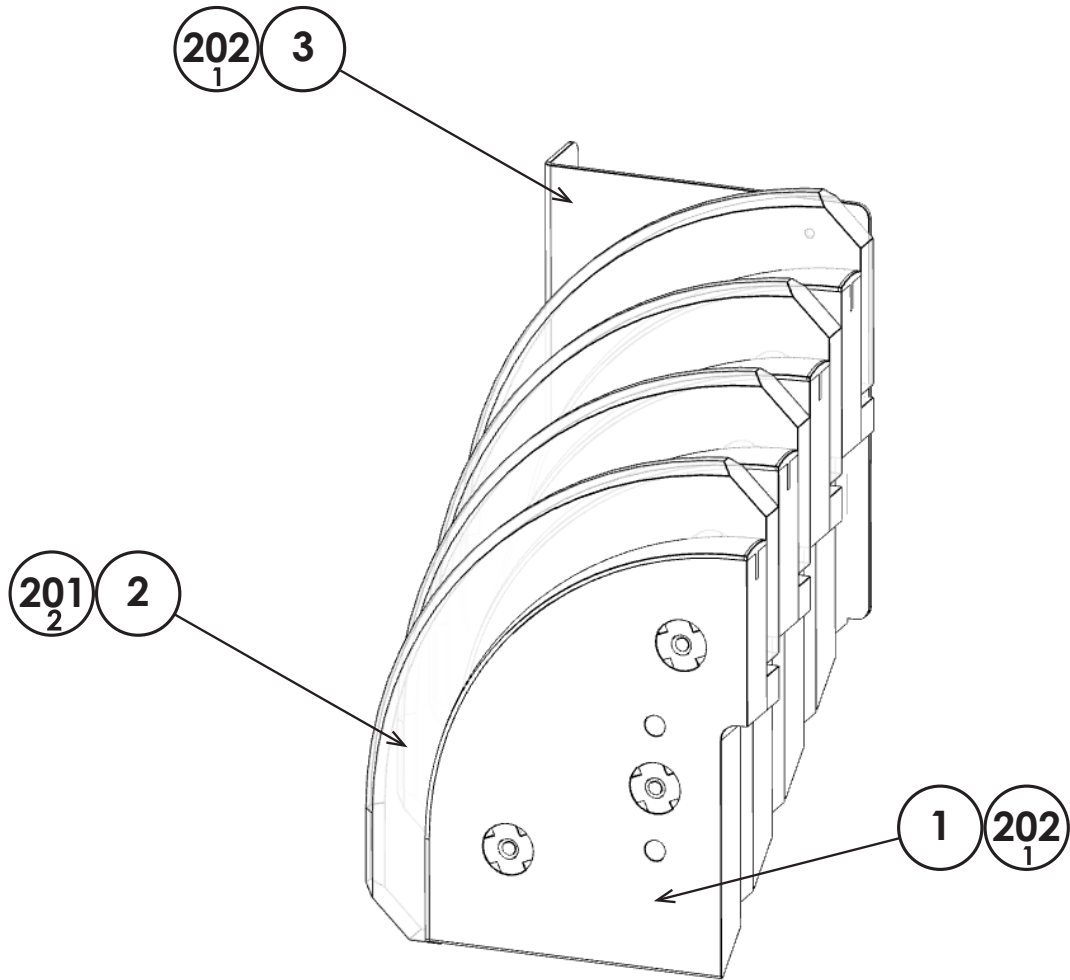

ITEM NO	PART NO	DESCRIPTION	QTY
***1	BI-1501UK	BASE LED CLUSTER L	4
***2	BI-1502UK	COVER LED CLUSTER L	4
***3	BI-1503UK	BRKT MTG LED CLUSTER	1
***201	020-F00630	M6X30 SKT CSK PAS	8
***202	029-B00650	M6X50 SKT BH PAS	4
***301	SAI-6201-0200UK	ASSY RGB LED SH	1

⑨ ASSY LED CLUSTER R (BI-1550UK)

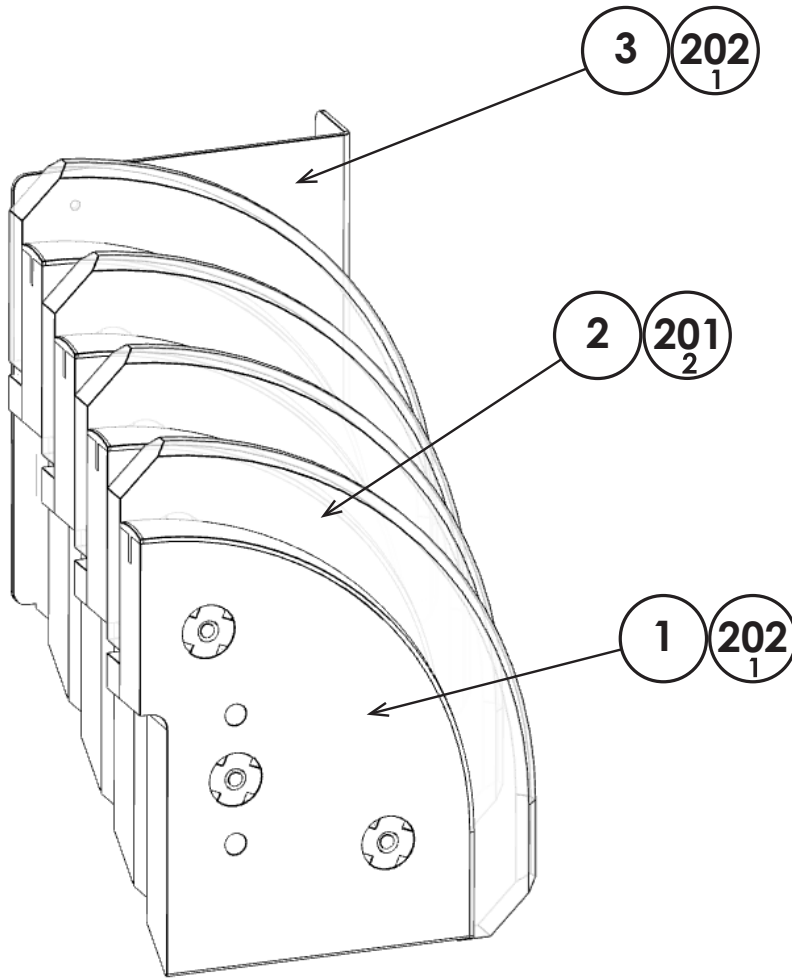

ITEM NO	PART NO	DESCRIPTION	QTY
***1	BI-1551UK	BASE LED CLUSTER R	4
***2	BI-1552UK	COVER LED CLUSTER R	4
***3	BI-1503UK	BRKT MTG LED CLUSTER	1
***201	020-F00630	M6X30 SKT CSK PAS	8
***202	029-B00650	M6X50 SKT BH PAS	4
***301	SAI-6201-0200UK	ASSY RGB LED SH	1

⑩ ASSY CTRL PANEL (BI-2100UK)

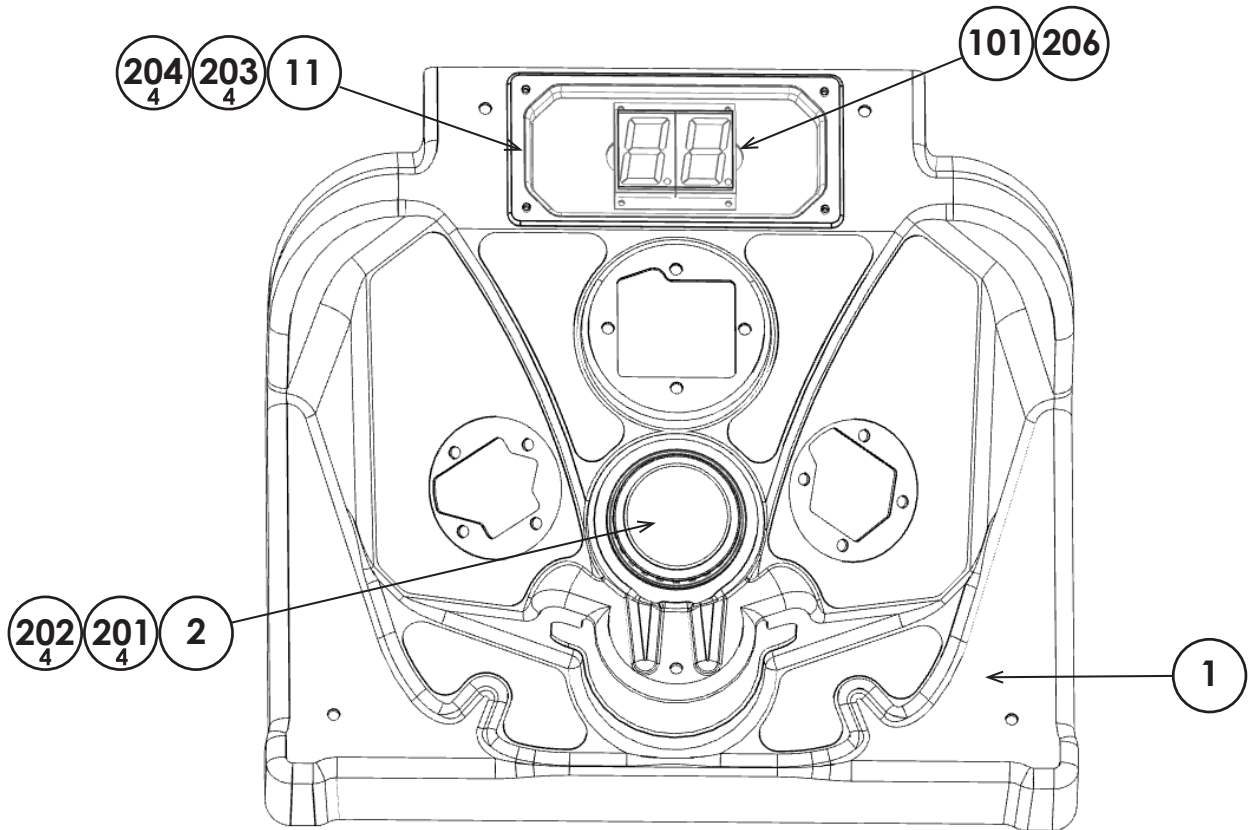

ITEM NO	PART NO	DESCRIPTION	QTY
***1	BI-2101UK	CONTROL PANEL COVER	1
***2	BI-2600UK	ASSY CTRL PUSH IT	1
***11	BI-2111UK	COVER DUAL LED	1
***101	838-0039UK	PCBA 2x7 SEG LED	1
***201	068-652216	M6 WSHR 22OD FLT PAS	4
***202	050-F00600	M6 NUT FLG SER PAS	4
***203	029-B00516	M5X16 SKT BH PAS	1
***204	050-F00500	M5 NUT FLG SER PAS	1
***206	OS1230	FOAM STRIP 2MM X 10MM	0.34M
***301	BI-60010UK	WH CAB EDGE LED	1
***302	BI-6006UK	ASSY LED CTRL PANEL	1

11 ASSY CTRL PULL IT (BI-2200UK)

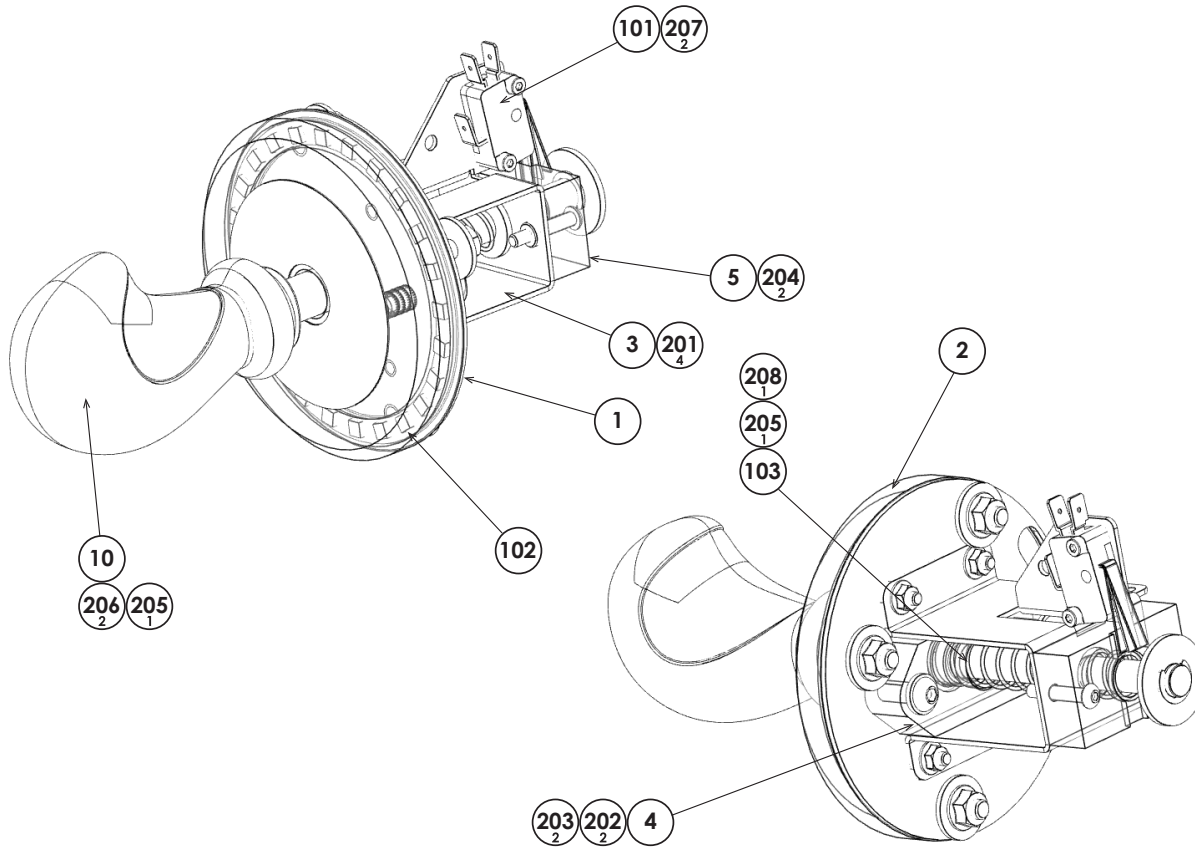

ITEM NO	PART NO	DESCRIPTION	QTY
***1	BI-2301UK	PLATE BASE TWIST IT	1
***2	BI-2202UK	BLOCK LIT PULL IT	1
***3	BI-2203UK	BRKT SWITCH MTG PULL IT	1
***4	BI-2204UK	BLOCK TOP ENDSTOP PULL IT	1
***5	BI-2205UK	BLOCK BTM ENDSTOP PULL IT	1
***10	BI-2220UK	ASSY SHAFT PULL IT	1
***101	EP1517	SW MICRO LS/LEV RS 804-6203	1
***102	390-2512-106RGB	RING LED 106MM RGB M10624	1
***103	125-0010UK	SPRING COMP PULL IT RETURN	1
***201	050-F00400	M4 NUT FLG SER PAS	4
***202	029-B00625	M6X25 SKT BH PAS	2
***203	060-F00600	M6 WSHR FORM A FLT PAS	2
***204	029-B00425	M4X25 SKT BH PAS	2
***205	065-E00700	E RING 7MM	3
***206	068-A52820	M10 WSHR 28OD FLT PAS	1
***207	020-000316-0Z	M3X16 SKT CAP 0Z	2
***208	060-F01000	M10 WSHR FORM A FLT PAS	1
***209	060-S00600	M6 WSHR SPR PAS	2
***210	060-S00400	M4 WSHR SPR PAS	2
***301	BI-60008UK	WH TWIST/PULL CNTRL	1

12 ASSY SHAFT PULL IT (BI-2220UK)

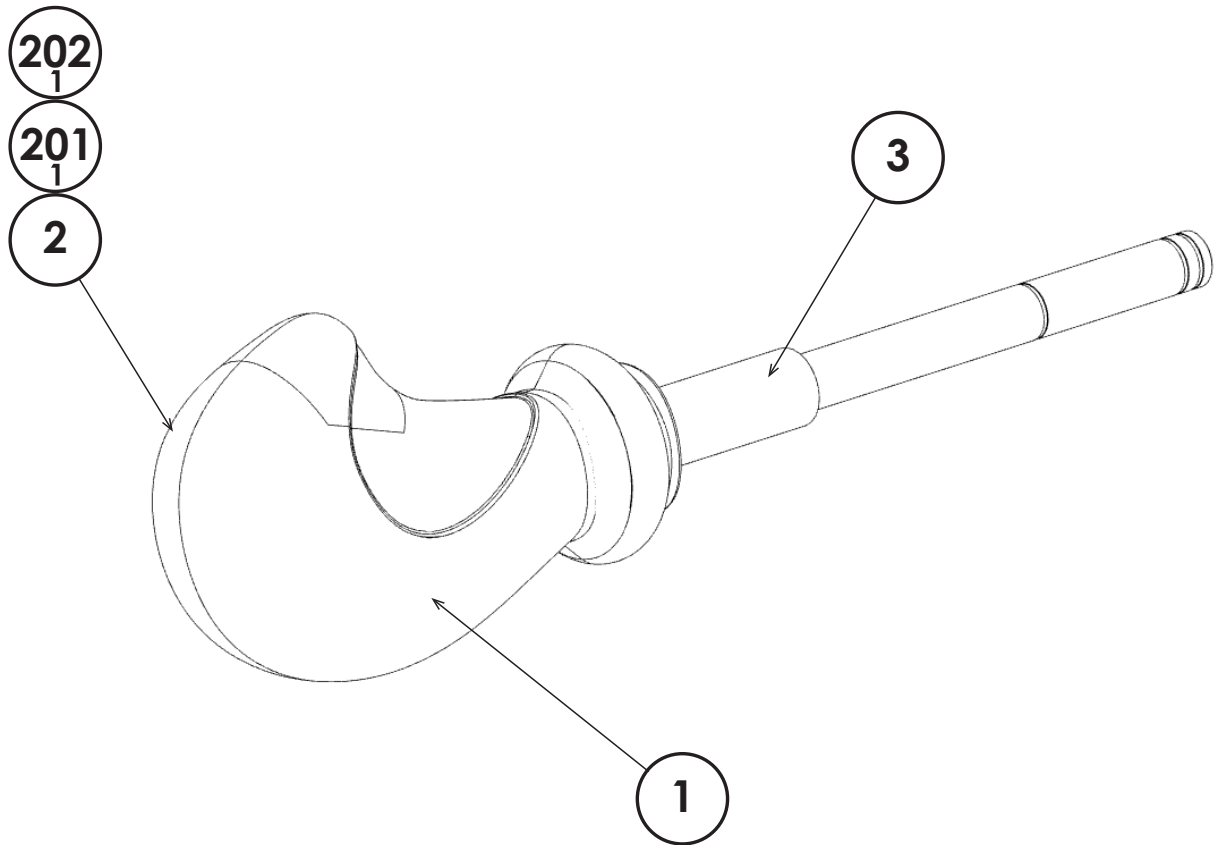

ITEM NO	PART NO	DESCRIPTION	QTY
****1	BI-2221UK	MOULD PULL IT FRONT	1
****2	BI-2222UK	MOULD PULL IT BACK	1
****3	BI-2223UK	SHAFT PULL IT	1
****201	029-B00525	M5X25 SKT BH PAS	1
****202	029-B00530	M5X30 SKT BH PAS	1

13 ASSY CTRL TWIST IT (BI-2300UK)

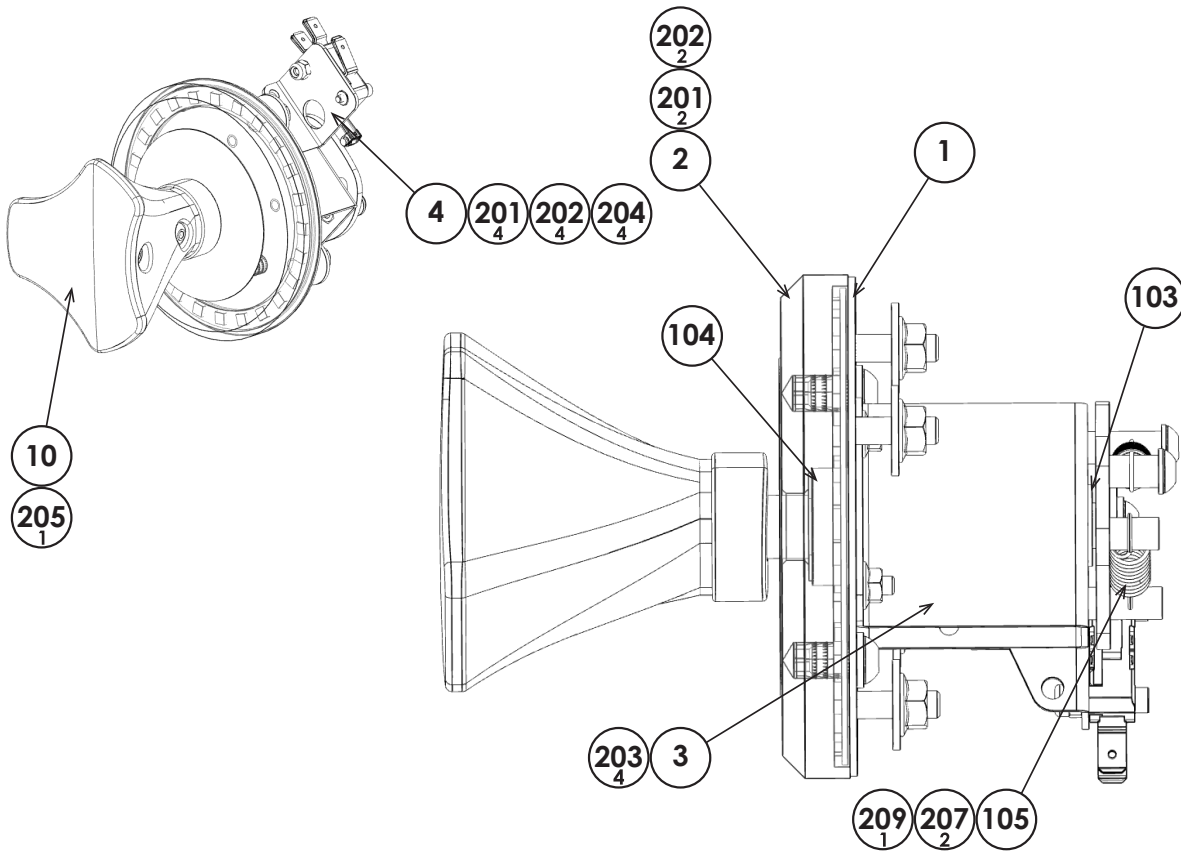

ITEM NO	PART NO	DESCRIPTION	QTY
***1	BI-2301UK	PLATE BASE TWIST IT	1
***2	BI-2302UK	BLOCK LIT TWIST IT	1
***3	BI-2303XUK	BRKT SWITCH MTG TWIST IT	1
***4	BI-2304XUK	PLATE CAM TWIST IT	1
***10	BI-2320UK	ASSY SHAFT TWIST IT	1
***101	EP1520	SW MICRO ROLLER LEVER 159-4449	1
***102	390-2512-106RGB	RING LED 106MM RGB M10624	1
***103	100-0001UK	FLANGED BEARING IGUS JFM-1012-09	1
***104	100-0006UK	BEARING DEEP GROOVE 10MM BORE SKF 60002Z	1
***105	125-0012UK	SPRING EXT TWIST IT RETURN	2
***201	029-B00612	M6X12 SKT BH PAS	3
***202	060-S00600	M6 WSHR SPR PAS	3
***203	050-F00400	M4 NUT FLG SER PAS	4
***204	060-F00600	M6 WSHR FORM A FLT PAS	1
***205	065-E00700	E RING 7MM	1
***206	020-000316-0Z	M3X16 SKT CAP 0Z	2
***207	029-B00512	M5X12 SKT BH PAS	4
***209	068-751815-PN	M7 WSHR 18OD FLT NYLON	2
***210	050-F00300	M3 NUT FLG SER PAS	1
***301	BI-60008UK	WH TWIST/PULL CNTRL	1

14 ASSY SHAFT TWIST IT (BI-2320UK)

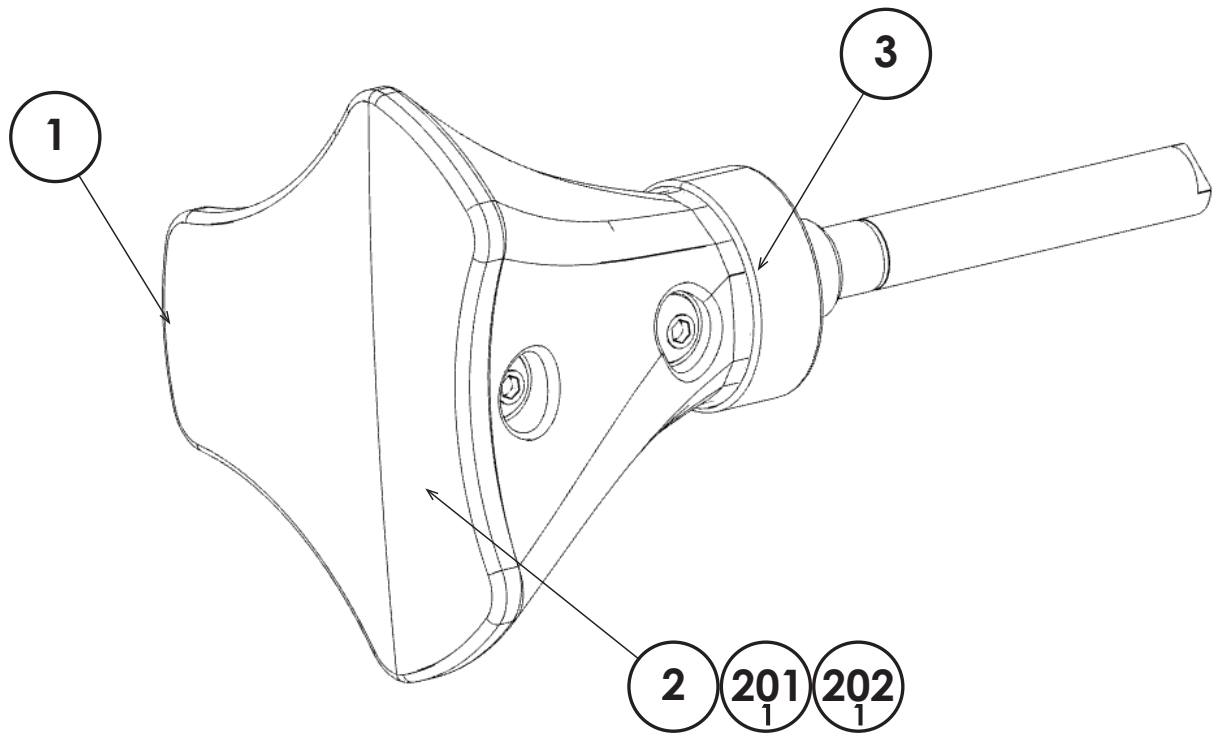

ITEM NO	PART NO	DESCRIPTION	QTY
****1	BI-2321UK	MOULD TWIST IT FRONT	1
****2	BI-2322UK	MOULD TWIST IT BACK	1
****3	BI-2323UK	SHAFT TWIST IT	1
****201	029-B00525	M5X25 SKT BH PAS	1
****202	029-B00520	M5X20 SKT BH PAS	1

15 ASSY CTRL FLICK IT (BI-2400UK)

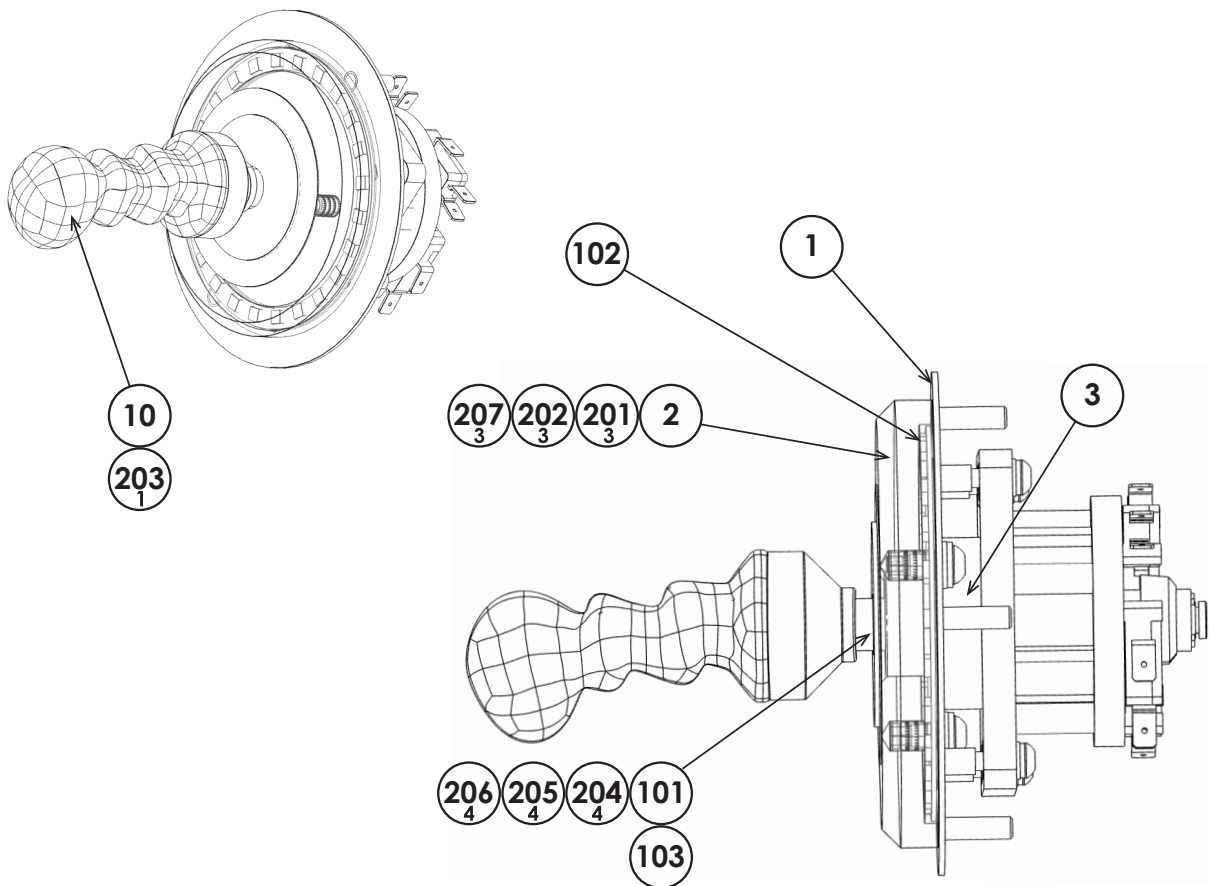

ITEM NO	PART NO	DESCRIPTION	QTY
***1	BI-2401UK	PLATE BASE FLICK IT	1
***2	BI-2402UK	BLOCK LIT FLICK IT	1
***3	BI-2403UK	GROMMET JOYSTICK	1
***10	BI-2420UK	ASSY SHAFT FLICK IT	1
***101	601-0014UK	JOYSTICK 8WAY 22-1076	1
***102	390-2512-106RGB	RING LED 106MM RGB M10624	1
***103	144-0001UK	WSHR EURO JOYSTICK GREEN L-C-03-040313	1
***201	029-B00612	M6X12 SKT BH PAS	3
***202	060-S00600	M6 WSHR SPR PAS	3
***203	065-E00700	E RING 7MM	1
***204	029-B00516	M5X16 SKT BH PAS	4
***205	060-S00500	M5 WSHR SPR PAS	4
***206	060-F00500	M5 WSHR FORM A FLT PAS	8
***207	060-F00600	M6 WSHR FORM A FLT PAS	3
***301	BI-60009UK	WH FLICK CNTRL	1

16 ASSY SHAFT FLICK IT (BI-2420UK)

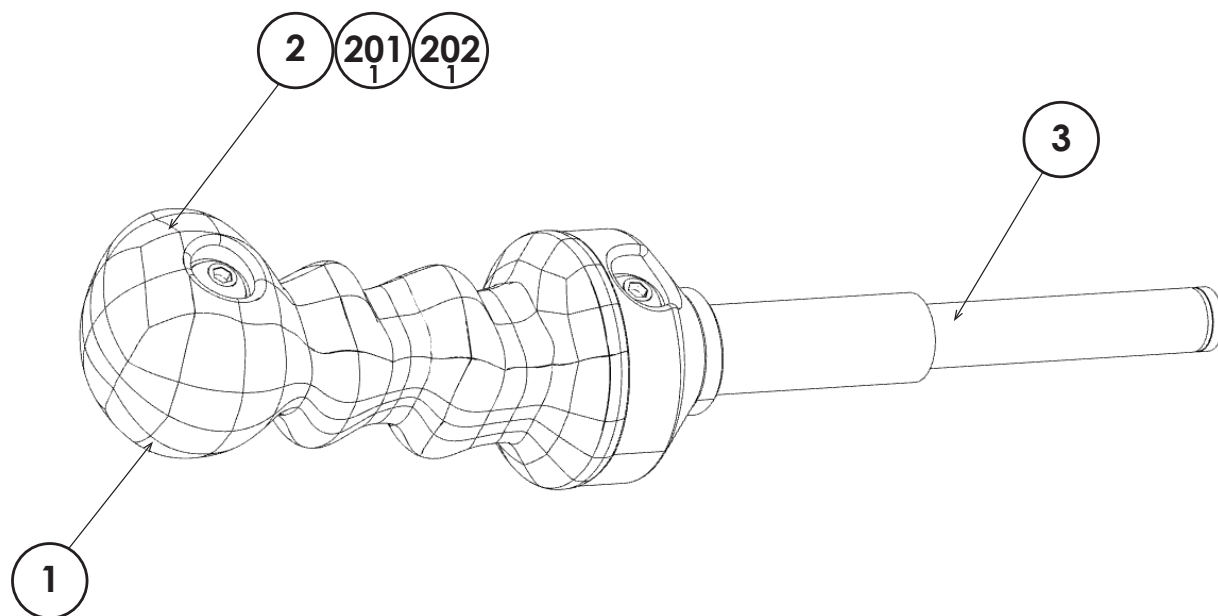

ITEM NO	PART NO	DESCRIPTION	QTY
****1	BI-2421UK	MOULD FLICK IT FRONT	1
****2	BI-2422UK	MOULD FLICK IT BACK	1
****3	BI-2423UK	SHAFT FLICK IT	1
****201	029-B00525	M5X25 SKT BH PAS	1
****202	029-B00520	M5X20 SKT BH PAS	1

17 ASSY CTRL SPIN IT (BI-2500UK)

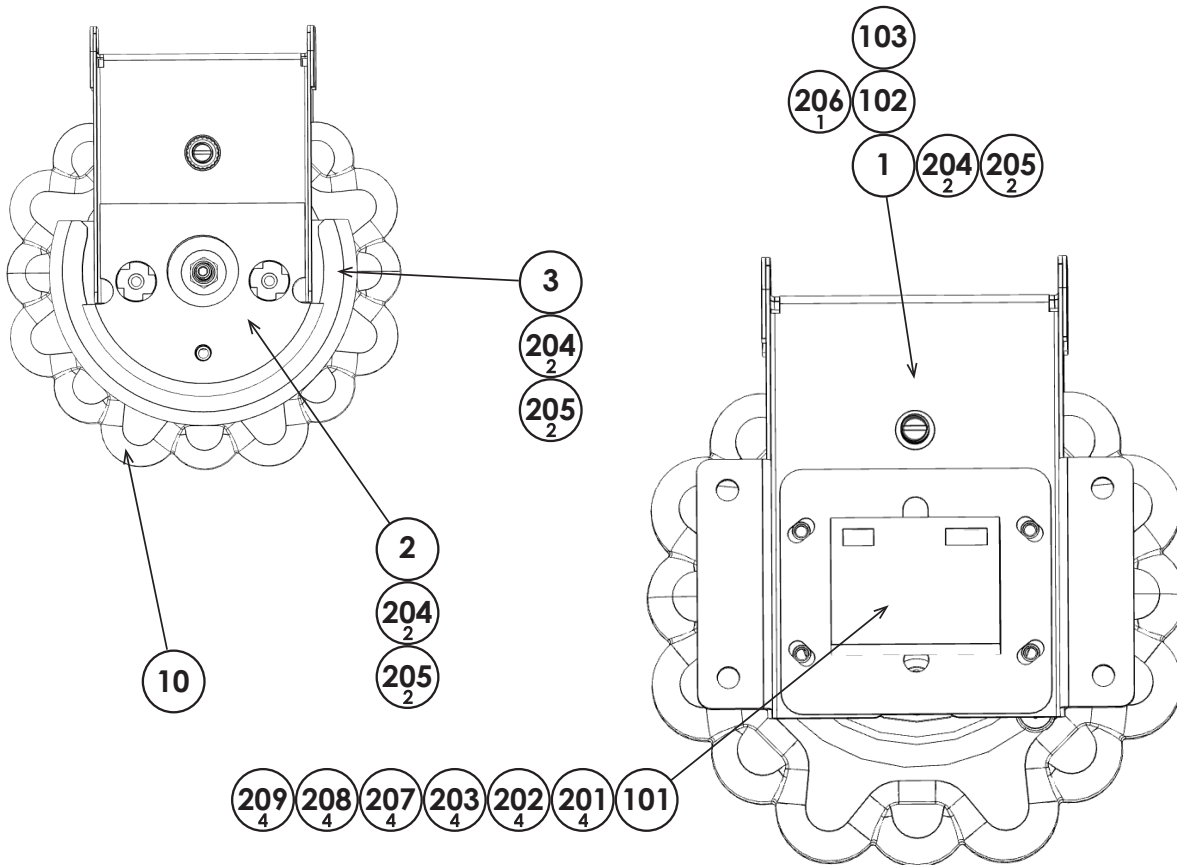

ITEM NO	PART NO	DESCRIPTION	QTY
***1	BI-2501UK	BRKT SPIN IT SUPP	1
***2	BI-2502UK	BLOCK LIGHT SPIN IT	1
***3	BI-2503UK	BLOCK TOP SPIN IT	1
***10	BI-2520UK	ASSY MOULD SPIN IT	1
***101	601-0011UK	CONTROLLER BL SPINNER	1
***102	028-0001UK	M8X20 SET SCR OZ NYLON TIP	1
***103	118-0001UK	M8X22 PLUNGER SPRING W/POM PIN	1
***201	060-F00400	M4 WSHR FORM A FLT PAS	4
***202	050-F00400	M4 NUT FLG SER PAS	4
***203	029-B00408	M4X8 SKT BH PAS	4
***204	020-F00620	M6X20 SKT CSK PAS	2
***205	000-F00412	M4X12 MSCR CSK PAS	2
***206	050-F00800	M8 NUT FLG SER PAS	1
***207	029-B00512	M5X12 SKT BH PAS	4
***208	060-S00500	M5 WSHR SPR PAS	4
***209	060-F00500	M5 WSHR FORM A FLT PAS	4
***301	BI-60007UK	WH SPIN CNTRL	1
***302	SAI-6101-0220UK	ASSY RGB LED LG	1

18 ASSY MOULD SPIN IT (BI-2520UK)

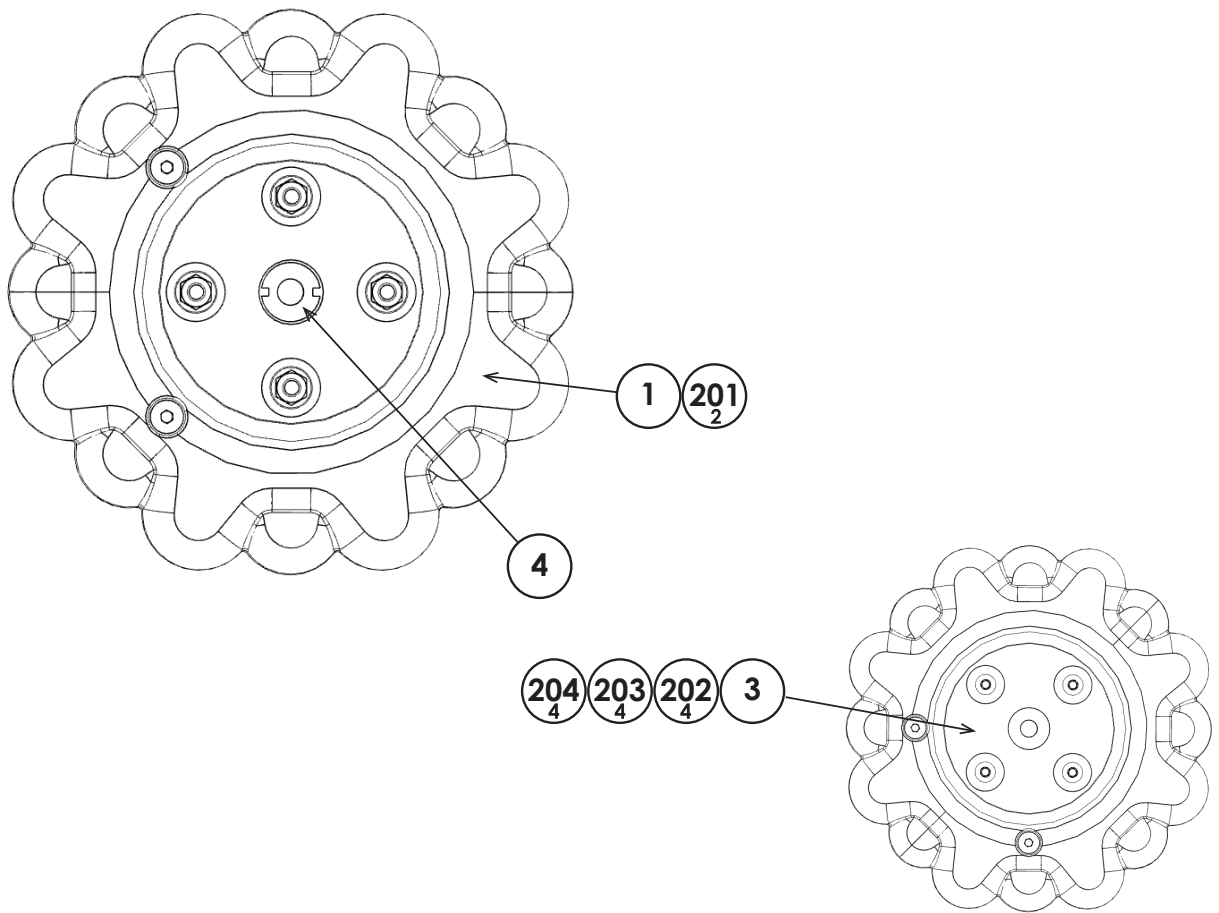

ITEM NO	PART NO	DESCRIPTION	QTY
****1	BI-2521UK	MOULD SPIN IT	2
****3	BI-2523UK	PLATE SPIN IT	1
****4	BI-2524UK	PLATE SPIN IT OS WASHER	1
****201	020-F00620	M6X20 SKT CSK PAS	4
****202	029-B00625	M6X25 SKT BH PAS	4
****203	068-652016	M6 WSHR 20OD FLT PAS	4
****204	050-F00600	M6 NUT FLG SER PAS	4

19 ASSY CTRL PUSH IT (BI-2600UK)

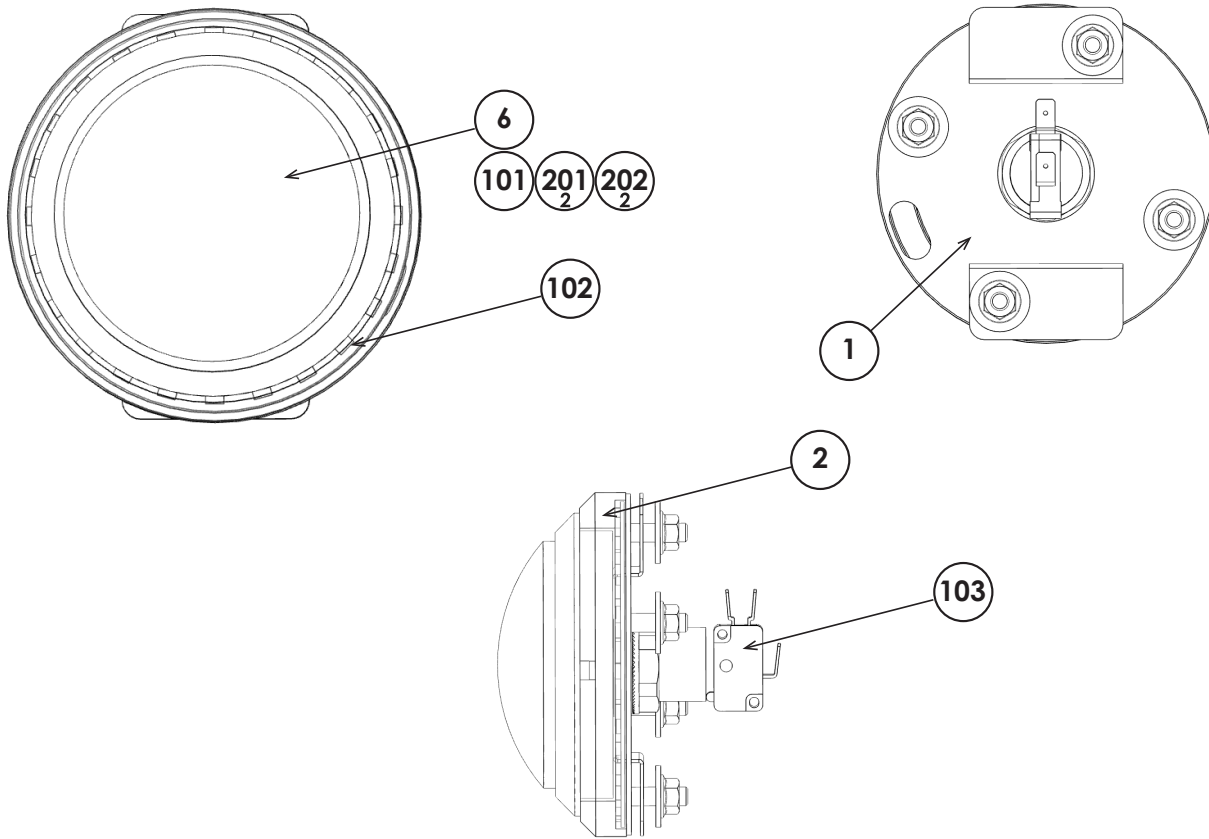

ITEM NO	PART NO	DESCRIPTION	QTY
****1	BI-2601UK	PLATE BASE PUSH IT	1
****2	BI-2602UK	BLOCK LIT PUSH IT	1
****6	BI-2611UK	INSERT PUSH IT	1
****101	509-6003-CUK	BTN JUMBO CLEAR H75-4002-11187	1
****102	390-2512-106RGB	RING LED 106MM RGB M10624	1
****103	509-6003-C-RGB	LAMP HOLDER RGB LED 12V 75-0019-00	1
****201	000-P00308	M3X8 MSCR PAN PAS	2
****202	060-S00300	M3 WSHR SPR PAS	2
****301	BI-60006UK	WH BOP CNTRL	1

20 ASSY MAIN DISPLAY (BI-3000UK)

(1/3)

17 PARTS LIST

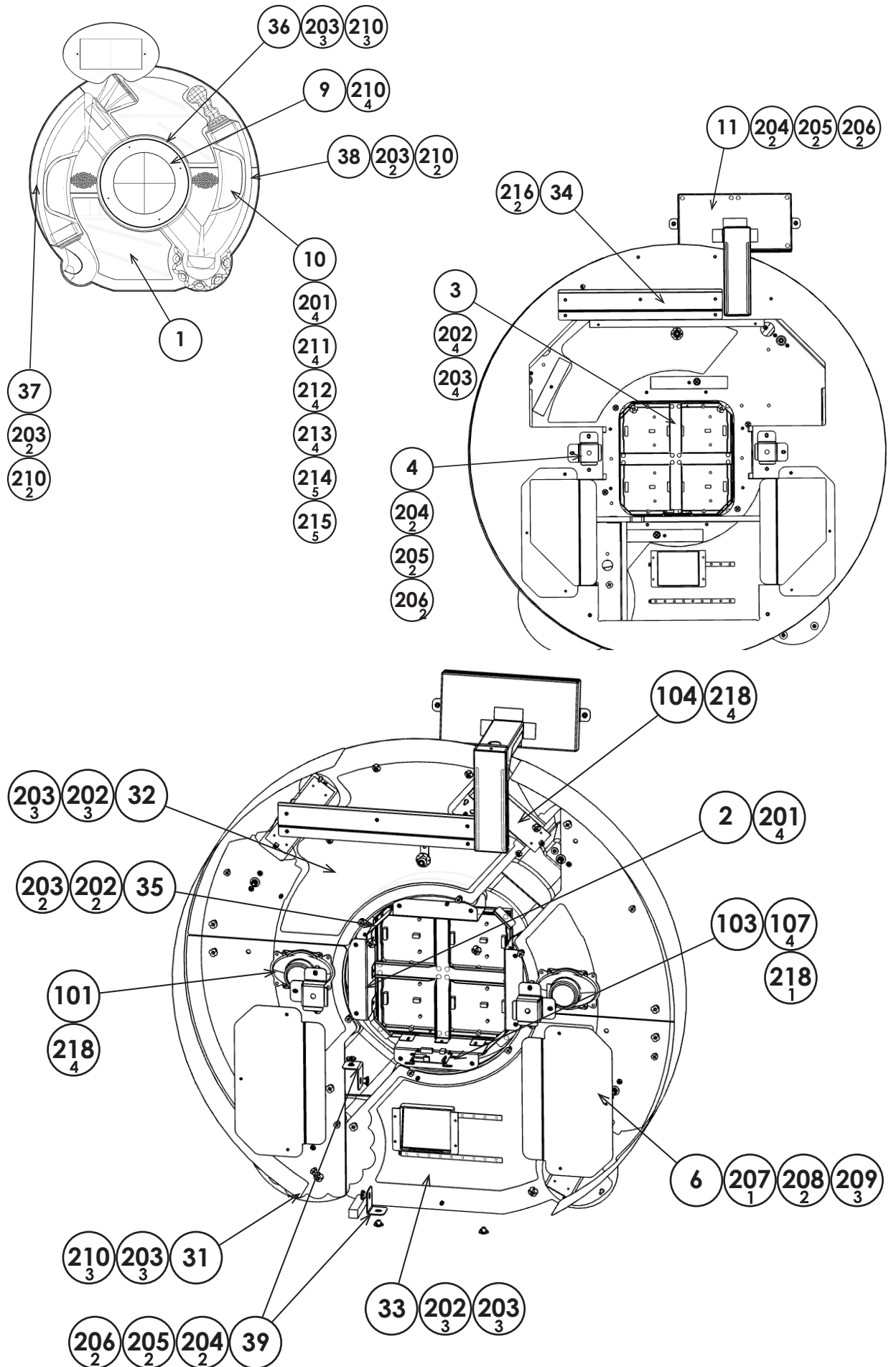

ITEM NO	PART NO	DESCRIPTION	QTY
***1	BI-3002UK	ASSY BOX DISPLAY	1
***2	BI-3003UK	BRKT VF SUPP	2
***3	BI-3004UK	BRKT MATRIX SUPP	1
***4	BI-3005UK	BRKT END STRUT	2
***6	BI-3007UK	PLATE COVER BACK BOX	2
***9	BI-3009UK	COVER VF CENTRE	1
***10	BI-3010UK	ASSY BOP IT	1
***11	BI-3100UK	ASSY BONUS BOX	1
***12	BI-3040UK	ASSY ELMTRI ENCLOSURE	1
***31	BI-3031UK	BLOCK SPIN IT LED MTG	1
***33	BI-3033UK	PLATE LED LIGHT BTM	1
***34	BI-3034UK	BRKT BILLBOARD LOCATE	1
***35	BI-3035UK	BRKT MATRIX SUPP OUTER	4
***36	BI-3036UK	CURVE LIGHT VF INNER	2
***37	BI-3037UK	CURVE LIGHT VF OUTER L	1
***38	BI-3038UK	CURVE LIGHT VF OUTER R	1
***39	BI-3039UK	BRKT BOX DISPLAY SUPPORT	2
***101	130-04030-E	SPKR ELIP 4OHM 30W VIS DX4X6P	1
***102	390-2805-3232P5	LED MATRIX P5-221-32*32	4
***104	838-0052UK	PCBA - LED MATRIX RGB	3
***105	280-A01264-WX	ROUTER TWIST D12 SO6.4 WOOD XL	1
***106	280-A02064-WX	ROUTER TWIST D20 SO6.4 WOOD XL	1
***107	OS1011	PCB FEET RICHCO LCBS-L-5-01	4
***108	OS1230	FOAM STRIP 2MM X 10MM	0.44M
***109	601-0460	CABLE TIE NYLON 100MM	18
***110	OS1247	ALUMINIUM STICKY CLIP ASK-3 475-198	2
***201	029-B00625	M6X25 SKT BH PAS	15
***202	029-B00412	M4X12 SKT BH PAS	18
***203	068-441616	M4 WSHR 16OD FLT PAS	31
***204	029-B00825-0B	M8X25 SKT BH BLK	9
***205	060-S00800-0B	M8 WSHR SPR BLK	9
***206	068-852216-0B	M8 WSHR 22OD FLT BLK	9
***207	029-B00412-0B	M4X12 SKT BH BLK	2
***208	029-B00416-0B	M4X16 SKT BH BLK	4
***209	068-441616-0B	M4 WSHR 16OD FLT BLK	6
***210	029-B00440-0B	M4X40 SKT BH BLK	17
***211	068-852216	M8 WSHR 22OD FLT PAS	4
***212	050-F00800	M8 NUT FLG SER PAS	4
***213	068-652216	M6 WSHR 22OD FLT PAS	4
***214	068-552016-0B	M5 WSHR 20OD FLT BLK	5
***215	050-F00500	M5 NUT FLG SER PAS	5
***216	029-B00625-0B	M6X25 SKT BH BLK	2
***217	029-B00640	M6X40 SKT BH PAS	5
***218	012-P03512-FB	N6X1/2" S/TAP FLG BLK	24

20 ASSY MAIN DISPLAY (BI-3000UK)

(3/3)

ITEM NO	PART NO	DESCRIPTION	QTY
***301	BI-60018UK	WH CAN ELMTRI	1
***302	BI-60019UK	WH DC DIST UPPER	1
***303	BI-60025UK	WH PCB MATRIX LINK	3
***304	SAI-6101-0430UK	ASSY RGB LED LG	1
***305	SAI-6603-0250UK	ASSY WHT LED SH	2
***307	SAI-6007-0100UK	WH RIBBON CABLE 100 16P	2
***308	SAI-6007-0550UK	WH RIBBON CABLE 550 16P	1
***309	SAI-6007-0250UK	WH RIBBON CABLE 0250 16P	1
***310	MI-60017UK	WH SPEAKERS A	2
***311	BI-60027UK	WH LED VAC DIST	1
***312	SAI-6201-0630UK	ASSY RGB LED SH	2
***312	SAI-6208-0630UK	ASSY RGB LED SH	2
***313	SAI-6108-0715UK	ASSY RGB LED LG	1
***314	SAI-6108-0625UK	ASSY RGB LED LG	1
***315	SAI-6007-1300UK	WH RIBBON CABLE 130016P	1

21 ASSY BOP IT (BI-3010UK)

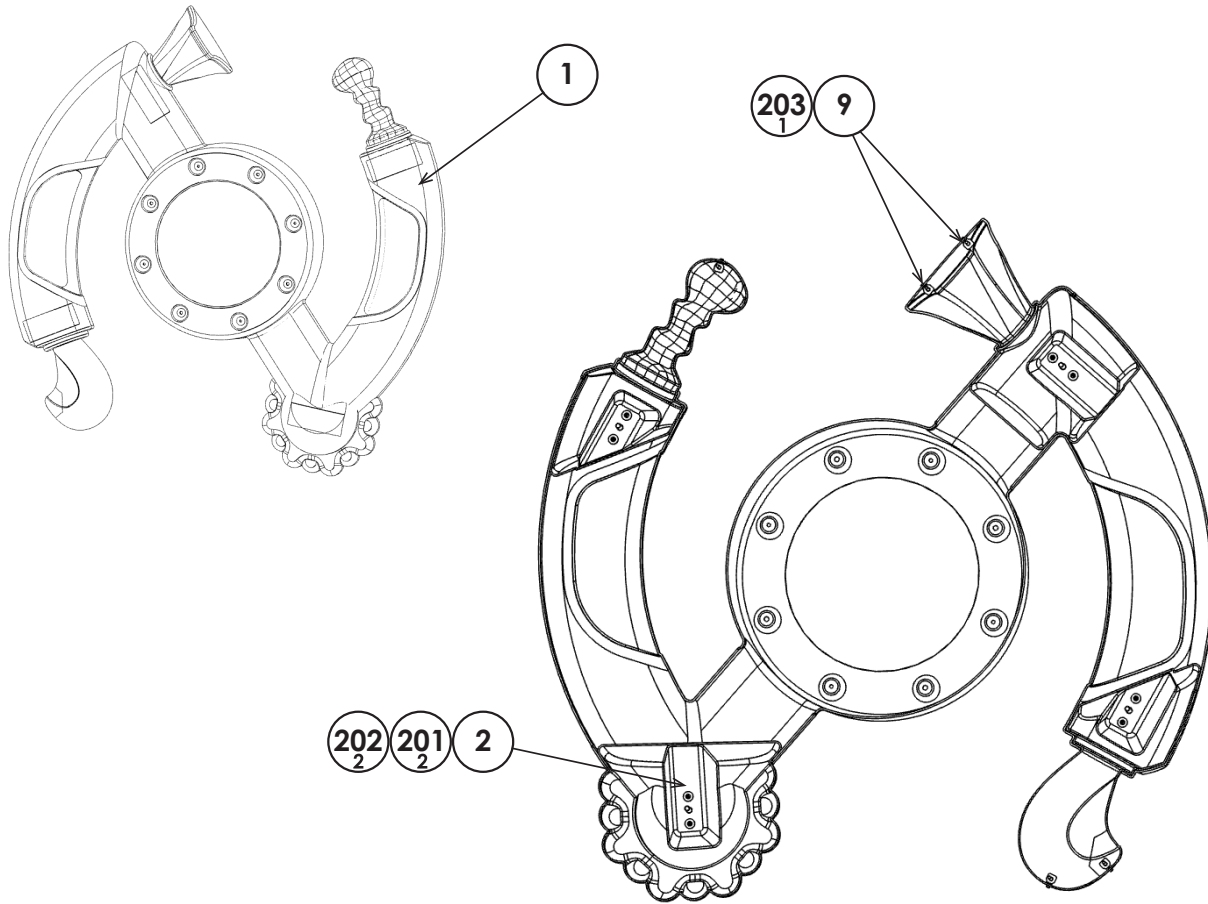

ITEM NO	PART NO	DESCRIPTION	QTY
****1	BI-3011UK	ASSY VF BOP IT	1
****2	BI-3012UK	BRKT VF ATTACH	4
****9	BI-3019UK	BRKT VF ATTACH SECONDARY	5
****201	029-B00412	M4X12 SKT BH PAS	8
****202	068-441616	M4 WSHR 16OD FLT PAS	8
****203	029-B00308	M3X8 SKT BH PAS	5

22 ASSY ELMTRI ENCLOSURE (BI-3040UK)

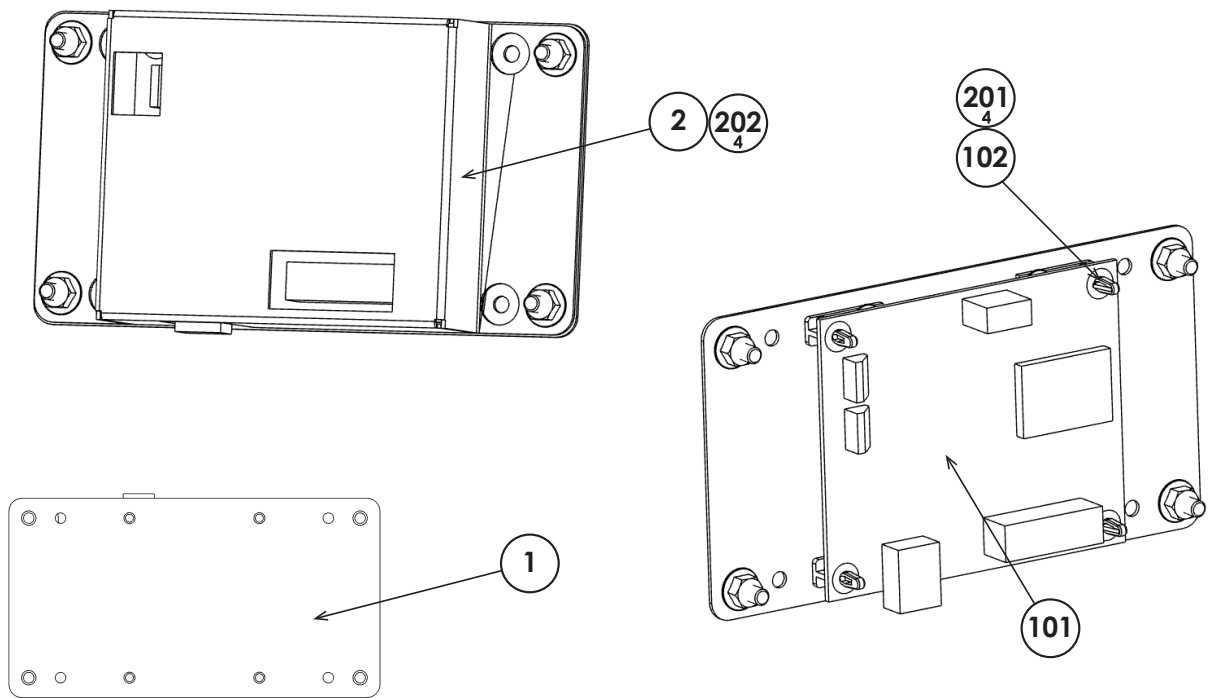

ITEM NO	PART NO	DESCRIPTION	QTY
****1	BI-3041UK	PLATE ELMTRI BASE	1
****2	BI-3042UK	COVER ELMTRI	1
****101	838-0061UK	PCBA - LED MATRIX DRIVER ELMTRI	1
****102	OS1011	PCB FEET RICHCO LCBS-L-5-01	4
****201	050-F00300	M3 NUT FLG SER PAS	4
****202	050-F00400	M4 NUT FLG SER PAS	4

23 ASSY BONUS BOX (BI-3100UK)

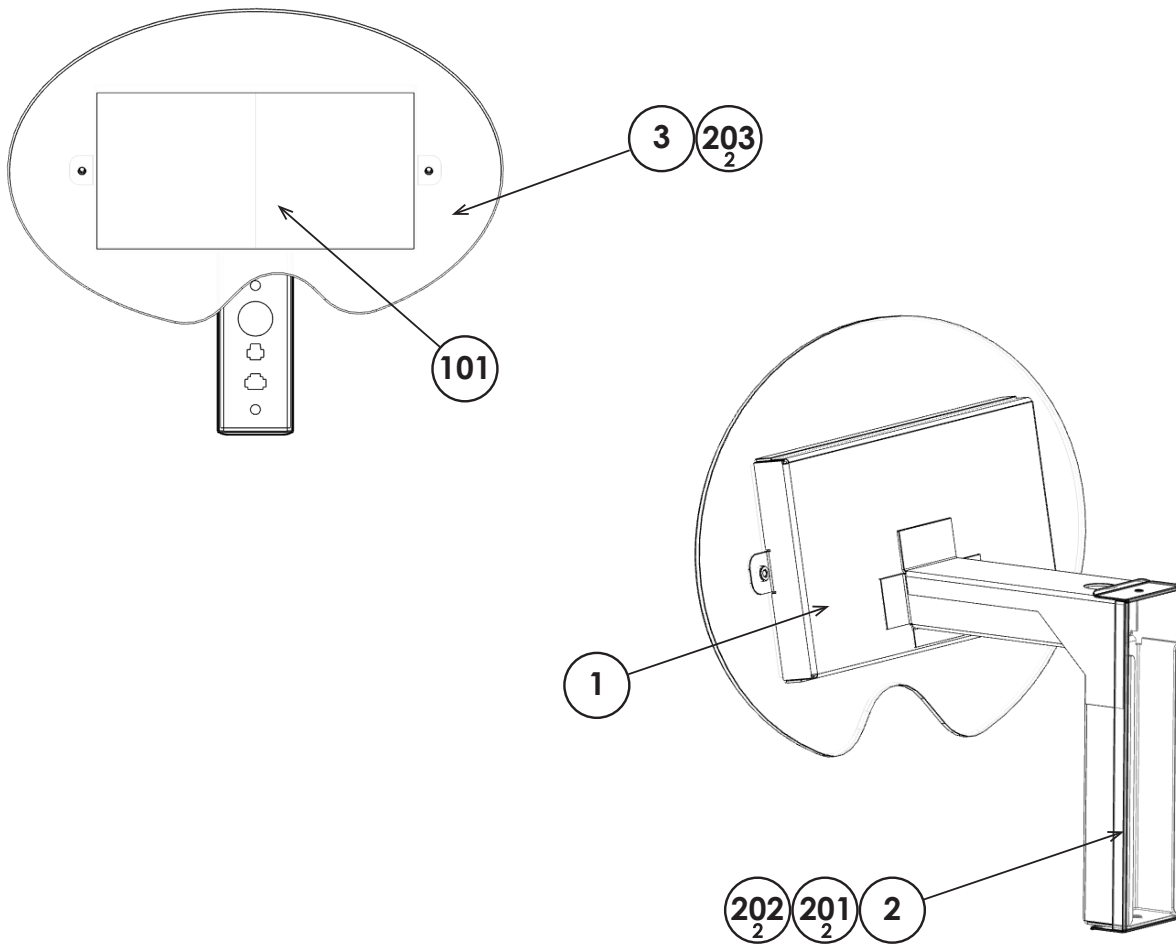

ITEM NO	PART NO	DESCRIPTION	QTY
****1	BI-3101UK	BOX LED MATRIX MTG	1
****2	BI-3102UK	COVER BACK BOX	1
****3	BI-3103UK	PLATE BONUS BOX	1
****101	390-2805-3232P5	LED MATRIX P5-221-32*32	2
****201	029-B00412	M4X12 SKT BH PAS	2
****202	068-441616	M4 WSHR 16OD FLT PAS	2
****203	029-B00612-0B	M6X12 SKT BH BLK	2
****301	BI-60021UK	WH BONUS MTX DC	1
****302	SAI-6007-0100UK	WH RIBBON CABLE 100 16P	1
****303	SAI-6008-0400UK	WH RIBBON CABLE M-F 400 16P	1

24 ASSY ELEC (BI-4000UK)

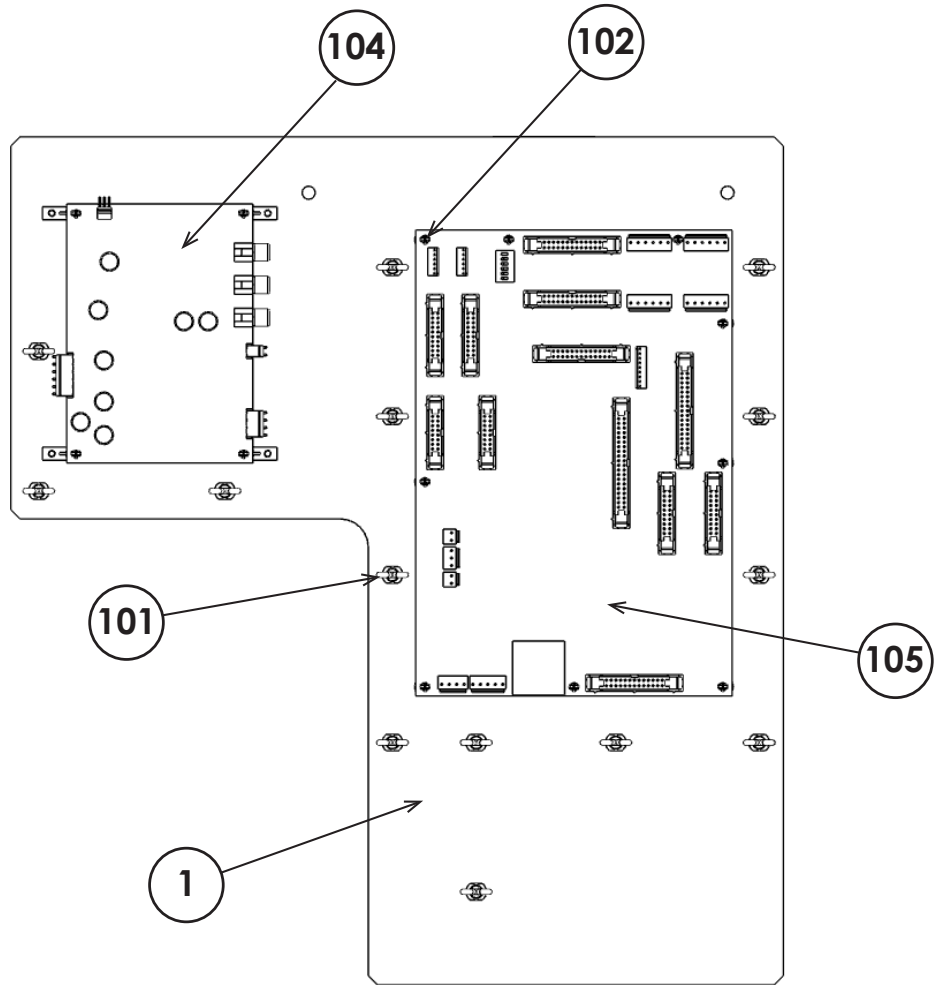

ITEM NO	PART NO	DESCRIPTION	QTY
**1	BI-4001UK	BOARD ELEC	1
**101	280-A01264-WX	ROUTER TWIST D12 SO6.4 WOOD X	12
**102	280-L00640-WX	STANDOFF 6MM WOOD XL	13
**104	838-0062UK	AUDIO BOARD HG2105	1
**105	838-0030UK	PCBA RED TWO	1
**109	EP1518	SD CARD MICRO 16GB FARNELL 3498606	1
**110	EP1435	SD CARD 2GB 758-2552	1
***201	012-P03512-F	N6X1/2" S/TAP FLG PAS	4
**301	BI-60003UK	WH DC CAN RED2	1
**302	BI-60004UK	WH I/O RED2	1
**303	BI-60020UK	WH AUDIO RS323	1
**304	600-7155-0100UK	CA AUDIO 3.5MM JACK	1

25 ASSY PSU (BI-4100UK)

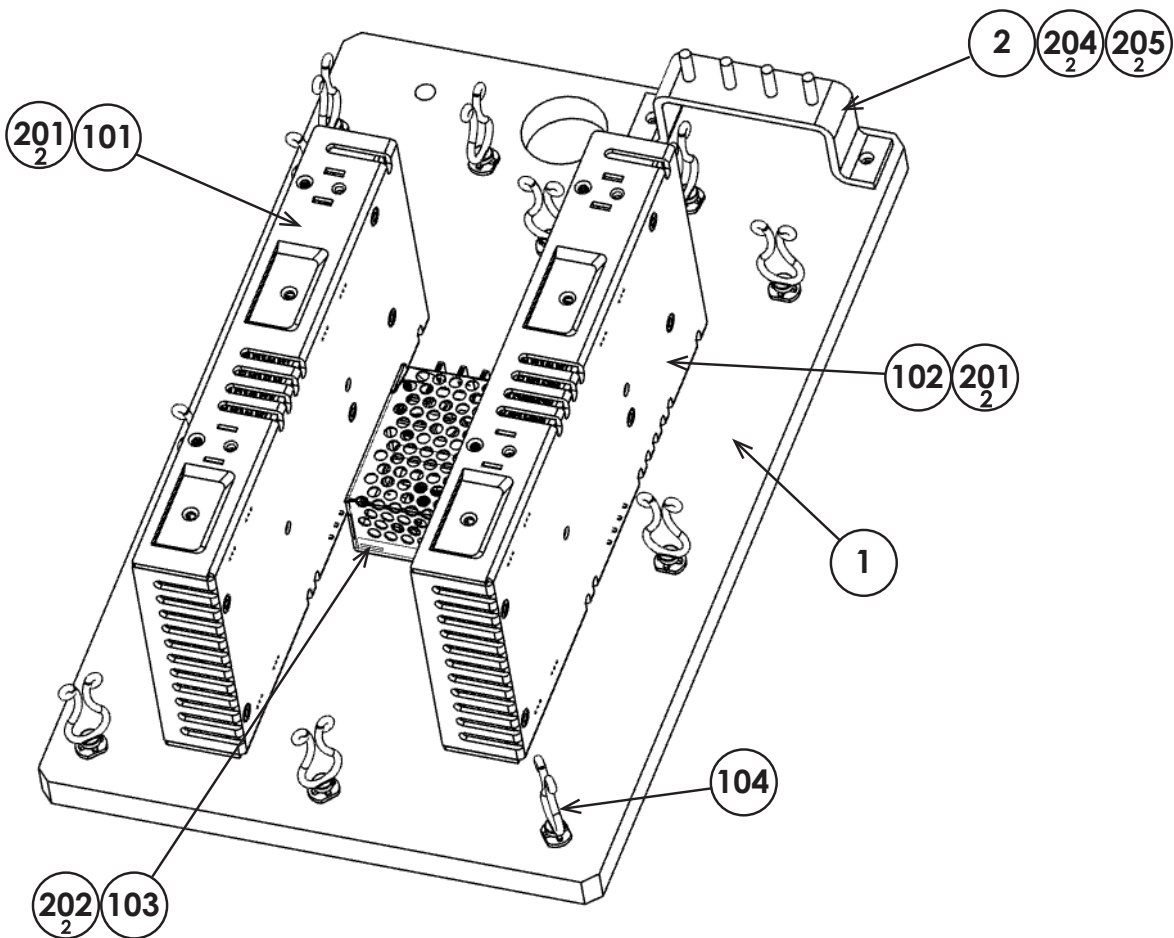

ITEM NO	PART NO	DESCRIPTION	QTY
**1	BI-4101UK	BOARD PSU	1
**2	CFB-4003-01UK	EARTH TERMINAL PLATE	1
**101	400-150-05-04	PSU 5VDC 150W RSP-150-05	1
**102	400-150-12-04	PSU 12VDC150W RSP-150-12	1
**103	400-015-005-03	PSU 5VDC 15W MW RS-15-5	1
**104	280-A01264-WX	ROUTER TWIST D12 SO6.4 WOOD XL	11
**201	000-F00416	M4X16 MSCR CSK PAS	4
**202	020-000308-0Z	M3X8 SKT CAP 0Z	2
**203	060-F00300	M3 WSHR FORM A FLT PAS	2
**204	012-P03512-F	N6X1/2" S/TAP FLG PAS	8
**205	050-F00400	M4 FLG NUT	2
**301	BI-60001UK	WH AC DIST	1
**302	BI-60002UK	WH DC DIST B	1
**303	BI-60016UK	WH DC A	1

26 ASSY INSTALL KIT BI (BI-INST)

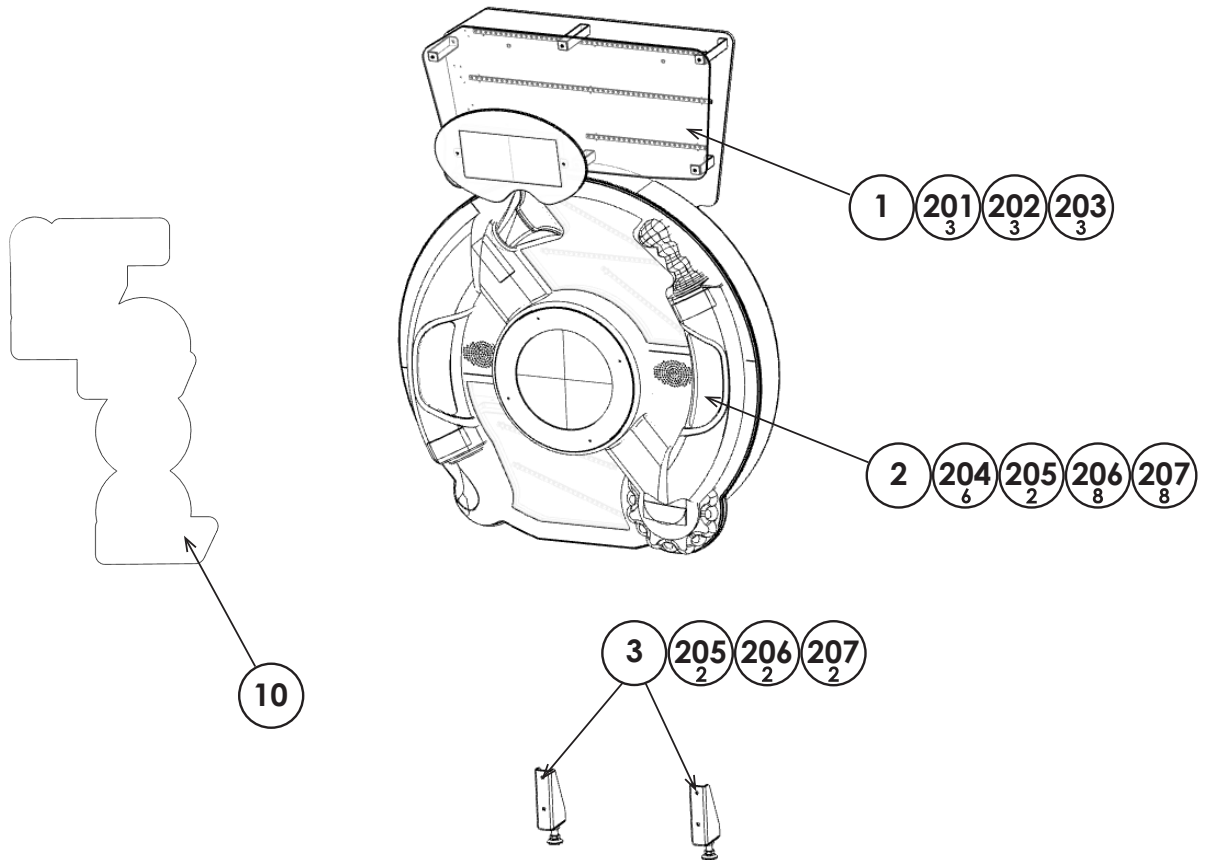

ITEM NO	PART NO	DESCRIPTION	QTY
**1	BI-0500UK	ASSY BILLBOARD	1
**2	BI-3000UK	ASSY MAIN DISPLAY	1
**3	BI-0100UK	ASSY STABILIZER BACK	2
**4	BI-0002UK	BRKT TRANSIT MAIN DISPLAY	2
**10	BI-3029UK	COVER QUADRANT TOP R ADDENDUM	1
**101	LM1227	UK MAINS LEAD 10A WITH PLUG	1
**102	LM1246	EUROLEAD 10A EUROPEAN SOCKET	1
**103	LM1500UK	MAINS LEAD USA/IEC H80-1205-00	1
**201	029-B00640-0B	M6X40 SKT BH BLK	3
**202	029-B00640	M6X40 SKT BH PAS	3
**203	068-652216	M6 WSHR 22OD FLT PAS	7
**204	029-B00850-0B	M8X50 SKT BH BLK	6
**205	029-B00825-0B	M8X25 SKT BH BLK	8
**206	060-S00800-0B	M8 WSHR SPR BLK	14
**207	068-852216-0B	M8 WSHR 22OD FLT BLK	14
**208	029-B00625	M6X25 SKT BH PAS	4
**209	060-S00600	M6 WSHR SPR PAS	4
**210	012-P03512-FB	N6X1/2" S/TAP FLG BLK	2
**301	RND-60055UK	WH COIN MECHANICAL	1

18 WIRE COLOR CODE TABLE

WARNING

The DC power wire color for this product is different from previous SEGA titles.
Working from the previous wire colors will create a high risk of fire

The color codes for the wires used in the diagrams in the following chapter are as follows:

- A PINK
- B SKY BLUE
- C BROWN
- D PURPLE
- E LIGHT GREEN

Wires other than those of any of the above 5 single colors will be displayed by 2 alphanumeric characters:

- 1 RED
- 2 BLUE
- 3 YELLOW
- 4 GREEN
- 5 WHITE
- 7 ORANGE
- 8 BLACK
- 9 GRAY

If the right-hand side numeral of the code is 0, then the wire will be of a single color shown by the left-hand side numeral (see the above).

Note 1: If the right-hand side numeral is not 0, that particular wire has a spiral color code. The left-hand side character shows the base color and the right-hand side one, the spiral color.

<Example> 51.....WHITE/RED

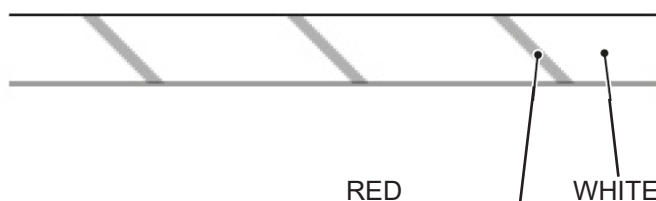

Note 2: The character following the wire color code indicates the size of the wire.

- U : AWG16
- K : AWG18
- L : AWG20
- None : AWG22

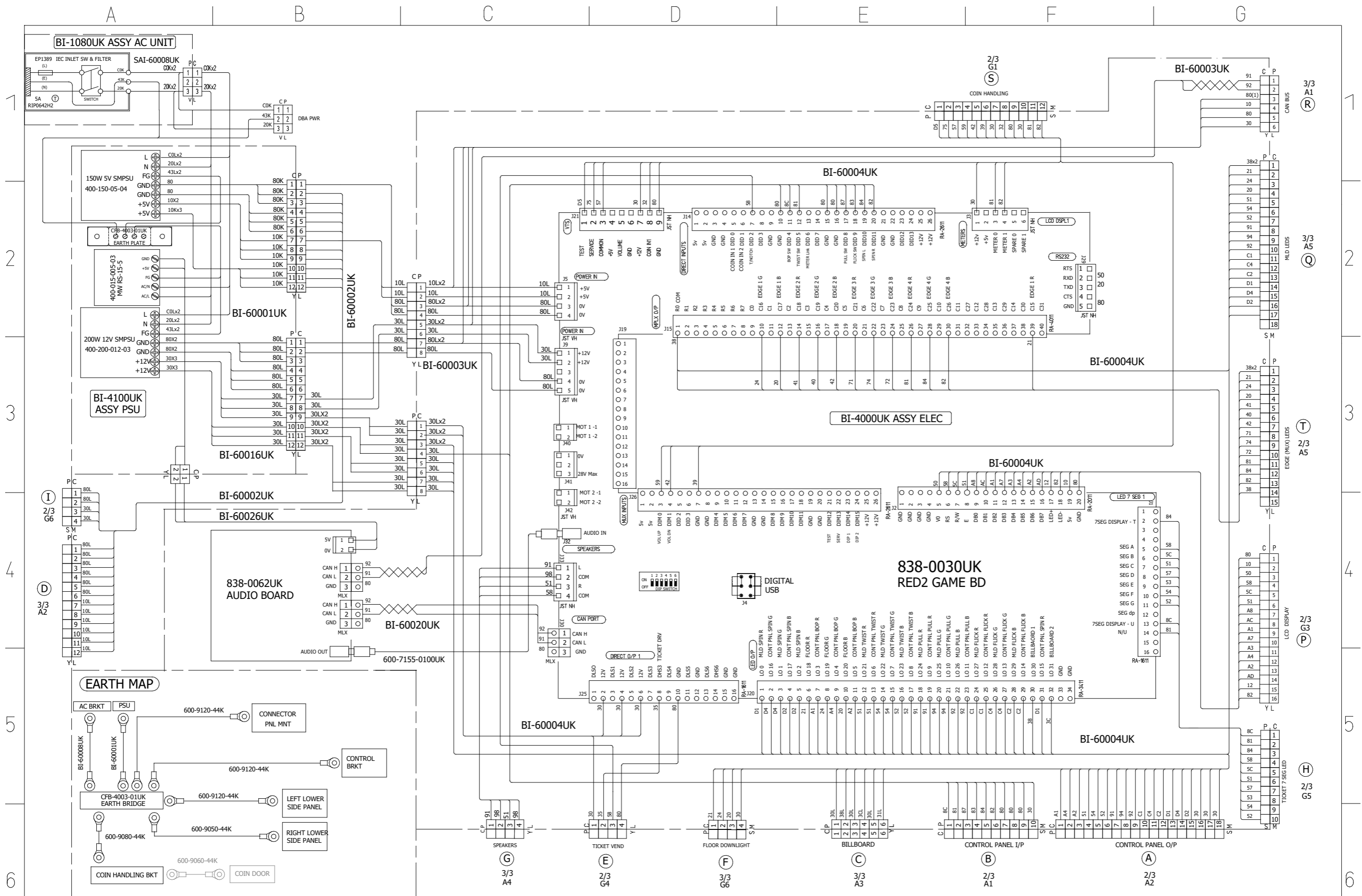

R1	7 SEG DISPLAY IDENT TAGS UPDATED	22/03/23	8 BLACK 7 ORANGE 5 WHITE 4 GREEN 3 YELLOW 2 BLUE 1 RED	13/05/16	43 EARTH WIRE ? AWG18 UL1672 ? AWG20 UL1672 U AWG16 UL1015 K AWG18 UL1015 L AWG20 UL1007 AWG22 UL1007 T AWG24 UL1007	BI-0000UK	23/01/23	CW	SEGA AMUSEMENTS INTERNATIONAL LTD	THIS DRAWING WILL IN NO WAY BE COPIED. TO BE RETURNED ON DEMAND.	PAGE 1/3	SIZE A2
			ALTERATION			PART NUMBER			DESCRIPTION			

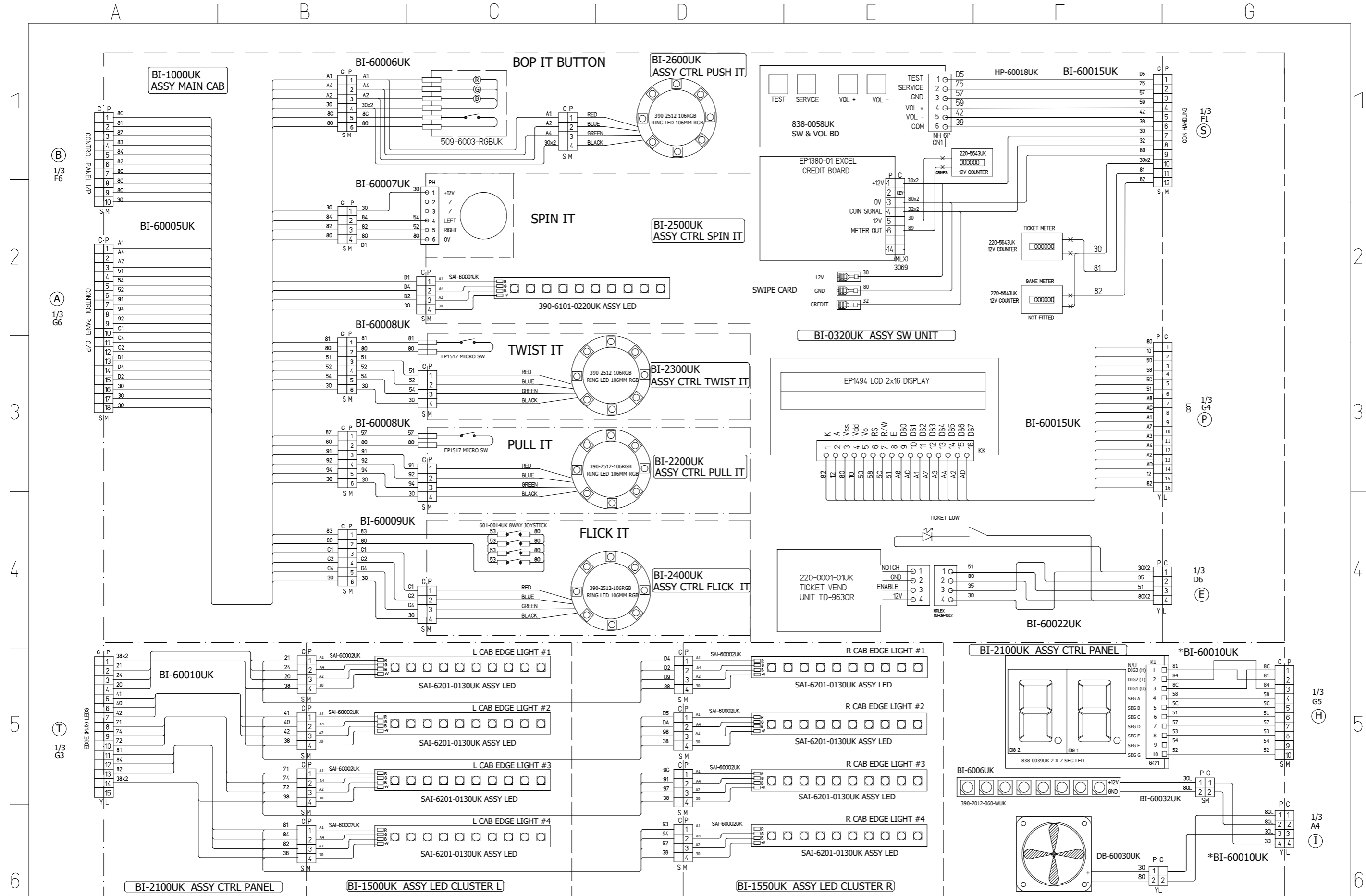

R1	7 SEG DISPLAY IDENT TAGS UPDATED	22/03/23	8 BLACK	E LIGHT GREEN	43 EARTH WIRE
			7 ORANGE	D PURPLE	? AWG18 UL1672
			5 WHITE	C BROWN	? AWG20 UL1672
			4 GREEN	B SKY BLUE	U AWG16 UL1015
			3 YELLOW	A PINK	K AWG18 UL1015
			2 BLUE	9 GRAY	L AWG20 UL1007
			1 RED		AWG22 UL1007
					AWG24 UL1007

BI-0000UK	23/01/23	CW		
PART NUMBER	DATE	DRAWN	CHECKED	

SEGA AMUSEMENTS INTERNATIONAL LTD		THIS DRAWING WILL IN NO WAY BE COPIED. TO BE RETURNED ON DEMAND.	
BOP IT ARCADE		PAGE 2/3	SIZE A2
DESCRIPTION			

1
2
3
4
5
6

1
2
3
4
5
6

(B) 1/3 F6

(A) 1/3 G6

(T) 1/3 G3

1/3 F1 (S)

1/3 G4 (P)

1/3 D6 (E)

1/3 G5 (H)

1/3 A4 (I)

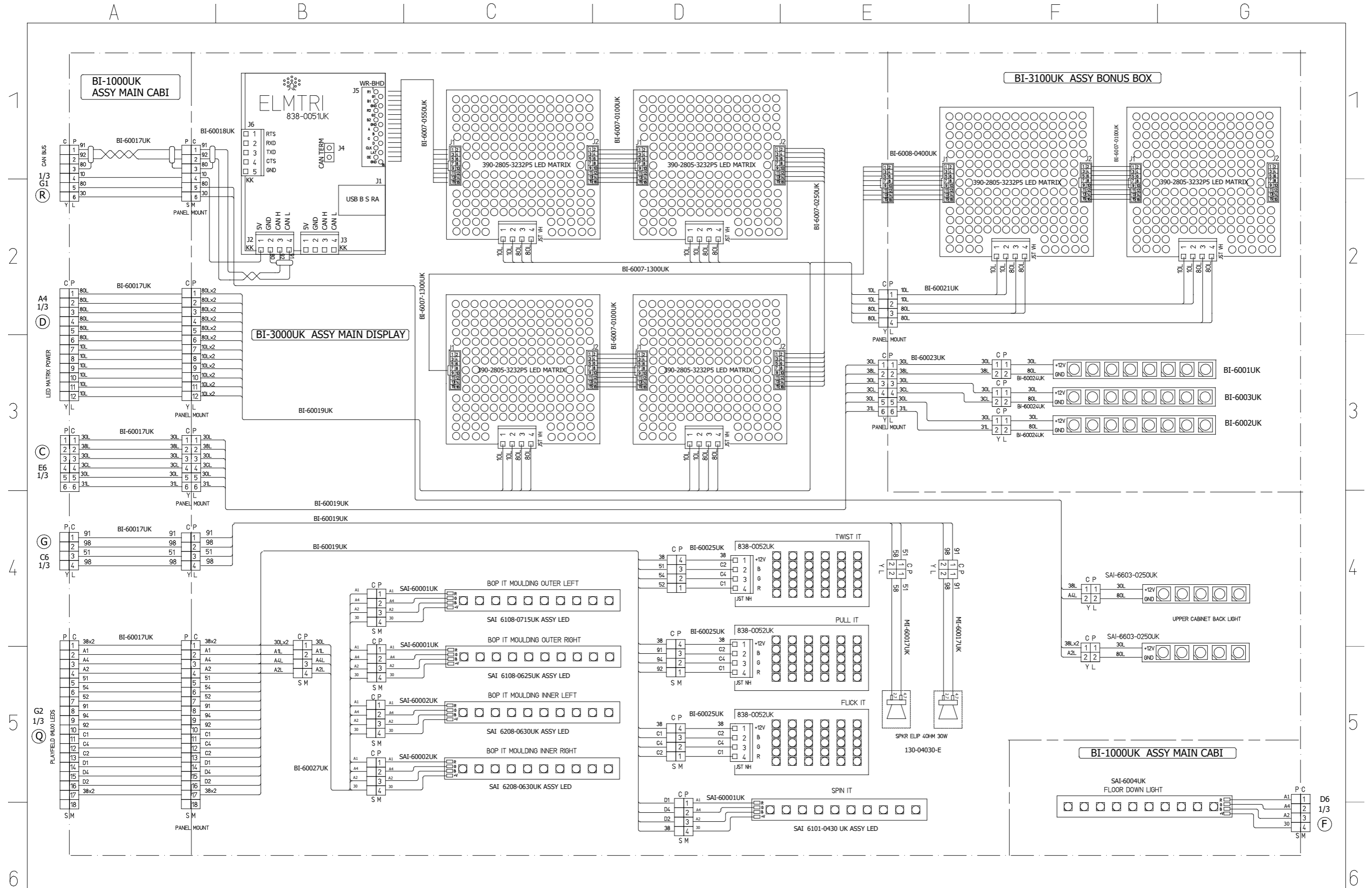

R1	7 SEG DISPLAY IDENT TAGS UPDATED	22/03/23	8 BLACK	E LIGHT GREEN	43 EARTH WIRE	BI-00000UK	23/01/23	CW	SEGA AMUSEMENTS INTERNATIONAL LTD	THIS DRAWING WILL IN NO WAY BE COPIED. TO BE RETURNED ON DEMAND.	PAGE	SIZE	
			7 ORANGE	D PURPLE	? AWG18 UL1672				BOP IT ARCADE		3/3	A2	
			5 WHITE	C BROWN	? AWG20 UL1672								
			4 GREEN	B SKY BLUE	U AWG16 UL1015								
			3 YELLOW	A PINK	K AWG18 UL1015								
			2 BLUE	9 GRAY	L AWG20 UL1007								
			1 RED		T AWG24 UL1007								
ALTERATION			PART NUMBER			DATE			DRAWN			CHECKED	
			DESCRIPTION										

SPARES AND SERVICE CONTACT INFORMATION



- SEGA TOTAL SOLUTIONS -

42 Barwell Business Park
Leatherhead Road,
Chessington,
Surrey,
KT9 2NY
United Kingdom

Parts: +44 (0) 2083918060
stssales@segaarcade.com

- TECHNICAL SUPPORT -

+44 (0) 2083918060
technical@segaarcade.com

- PLAY IT AMUSEMENTS -

870 Lively Blvd
Wood Dale,
IL,
602191
United States of America

Parts/Customer Service: +00 (1) 224 265 4287
Technical Support: +00 (1) 224 265 4283
PIA: support@playitamusements.com

