



## User Manual

Please read the instruction carefully before installation and use

# Catalogue

1. Safety Precautions.....	2-5
2. Product parameters.....	6
3. Spare Parts List.....	7
4. Machine Installation.....	8-20
5. Inner Components.....	20-22
6. How to play.....	22
7. Game Setup.....	22-24
8. Game Play.....	25-27
9. Troubleshooting Guide.....	27-28
10. Wearing Parts list.....	29
11. Caution & Warning Stickers.....	30
12. Wire Dia.....	31

# 1. Safety Precautions



## 1.1 Warning Stickers

---

In order to avoid injury to related people and damage to property, please observe the followings:

### PLEASE READ FIRST

- The following marks can be used to indicate the magnitudes of risk and damage caused by ignorance or improper operation:

 <b>Warning</b>	means “may result in serious injury or death”
 <b>Caution</b>	means “may result in minor injury or property damage”

**Serious Injury:** refers to the situations in which hospital treatment or long-term treatment will be accepted because of losing sight, getting hurt, getting burnt, electric shock, fracture or intoxication.

**Minor Injury:** refers to the cases that there is no need to go to hospital or accept long-term treatment.

**Property Damage:** refers to the damage of house, facility, or hurt of livestock and pet

## 1.2 Placing Site

---

### **Warning**

- please make sure the place line has been grounded before product installation, setup, testing, operation or repair
- This machine is designed for indoor use only. Never install the machine outdoors. Meanwhile, please avoid the following locations indoor:
  - Direct sunlight, water leakage, damp and high temperature places.
  - Near Flammable, volatile, or/and dangerous substance.
  - Slope, unstable places or locations subject to frequent vibration.
  - Near emergency exit, fire extinguisher or similar equipment.
- The rear part has the vent for heat emission from PC or screen. Don't place anything nearby to avoid game failure.
- Provide a space of minimum 30cm between the rear of the machine and the wall for good ventilation and heat emission

## 1.3 Safety Precautions

---

The owner shall pay attention to the followings when placing, checking and repairing machine to insure player's security and avoid damage:

### **Warning**

- please check the voltage is 110V or 220V before the machine connects to the power supply, or it may cause a fire or electric shock.
- Make sure to plug the game into 110V or 220V main outlet to avoid fire and electric shock.
- Make sure to turn off the power when performing maintenance and service to avoid electric shock or short circuit.
- Do not unplug or plug the plug instantly.
- Don't touch the power plug with a wet hand to avoid electric shock.
- Don't expose the power cord/grounding line on the passageway. Failure to do this will damage the power cord, causing electric shock or short circuit.
- Don't lay anything near the power cord to avoid fire.
- Do not pull the power cord when unplugging, please hold the plug to avoid power cord damage, causing fire or electric shock.
- In case of power cord damage, please contact the local distributor for replacement
- Only use fuse and spare parts specified by our company
- Connect the connector firmly and tighten the screws.
- It is forbidden to push or pull the game-machine in order to prevent the accidental danger.
- Do not dismount, replace or convert the product without our permission in order to avoid damage and human injury due to improper operation.
- Check and maintain the machine regularly.
- Keep "Warning stickers" clean and legible. Replace it immediately when the words are not legible or the dirt can't be removed.
- Please contact our service center when performing any work that is not described in this manual, and follow the instruction provided.

## 1.4 Precautions during Play

### **Caution**

- In order to avoid injury and accident during play, the following people shall not play the game:
  - People who are injured or less mobile.
  - Person with poor health condition, such as hypertension or heart disease.
  - Person wearing high-heeled or slippery shoes.
  - Person who can't touch the pedal.
  - Pregnant woman, drunk people.
- When a player feels uncomfortable during play, remind the person to have a break, or stop playing.
- Make sure the player reads the warning labels and other indications, and plays in accordance with the instructions to avoid accidents such as electric shock and short circuit.
- Bystander shall not operate any button when the player is playing the game to avoid unnecessary trouble.
- It is forbidden to push or pull the game-machine in order to prevent the accidental danger.

## 1.5 Transporting and Moving

### **Caution**

#### Transporting

- When transporting the machine with an elevator, be sure to employ "Lift Point" to prevent accident and damage to the machine.
- To prevent movement when transporting the machine on a vehicle, please fix the casters and fully retract the adjusters. Failure to do this may cause damage to the machine.
- When carrying the machine with a forklift, be sure to insert the fork to fork position and lift stably. If not, it may cause accident and damage to the machine.
- The Acrylic of the machine is fragile. High precision components are required for vibration or shock resistance.

#### Moving

- Before moving the machine, unplug the power plug to prevent accident. Don't damage the cord.
- Pay attention to the obstructions and uneven surface when moving the machine to prevent accident and damage to the machine.
- Fully retract all adjusters before moving to prevent accident and hazard.
- Make sure to use at least two persons to conduct the above work to avoid accident and injury
- Pay attention to the moving direction, see fig.



## 1.6 Installing and Placing

Pay attention to the following when placing the machine.

### Caution

- Place the machine on the flat and slip resistant area.
- Use the adjusters to fix the machine (See diagram 1)
  1. Loosen the nuts for the adjusters (clockwise), tighten the bolts with a wrench (clockwise).
  2. Tighten the nut firmly (counter clockwise) and fix it well.

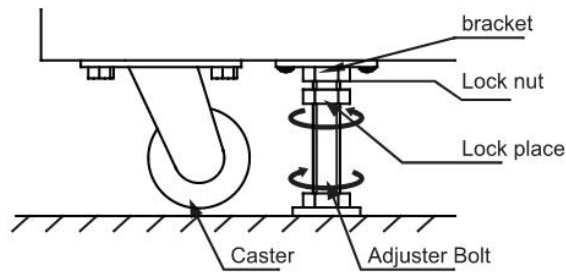

Diagram (1)

- Provide a space of minimum 30cm between the rear of the machine and the wall for good ventilation and heat emission (See diagram 2).

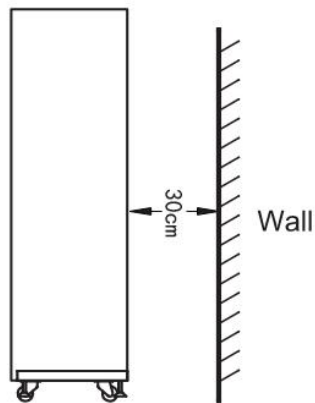

Diagram (2)

## 2. Product Parameters

Size: D2432mm\*W1030mm\*H2565mm

Weight: 300kg

Voltage: 220V Frequency: 50Hz-60Hz

Power: 540W-600W



### Summary:

Hoop Shot is an arcade game in which players attempt to score a basket for target scores. Additionally, with a 65inches large LED screen, players experience with celebration components, game prompts and ranking.

### 3. Spare Parts List

Parts Name	Quantity	Remarks
User Manual	1	
AC Power line	1	
Key	2	
Screw	Several	
Basketball	6	
Ball pump	1	
Gas needle	1	

## 4. Machine Installation

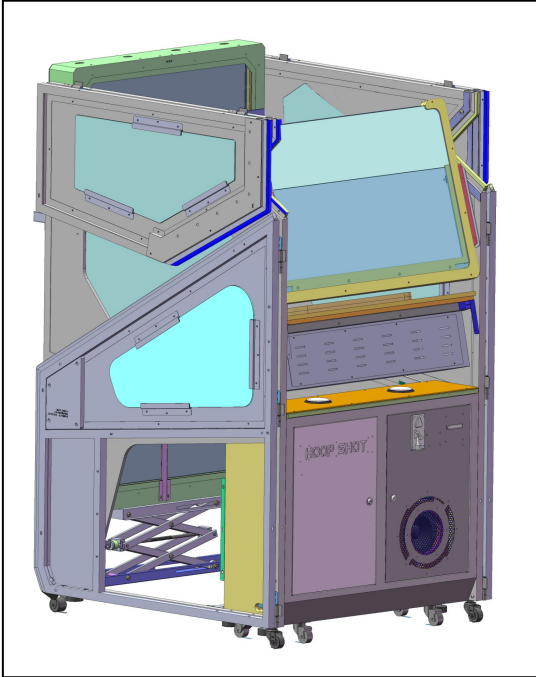

**1**、 Complete package, remove carefully the machine from the pallet.

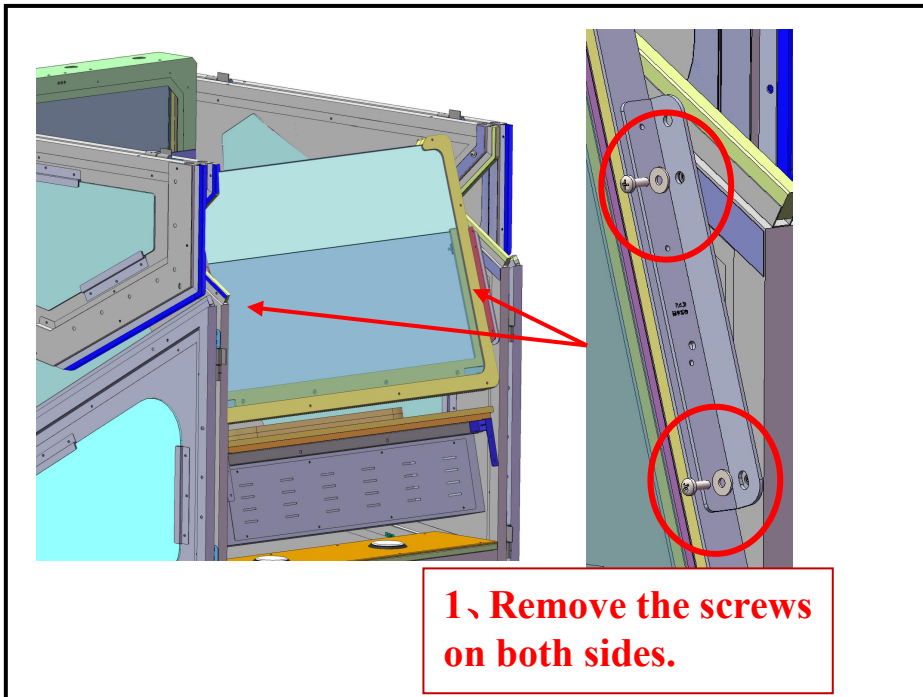

**2**、 Remove the baffle acrylic (4 screws on the left and right);



**3.** Remove the rubber posts (2 on the left and right) that fix the upper side plate, and screw them straight. Pay attention to insert the light connector into the hole first;

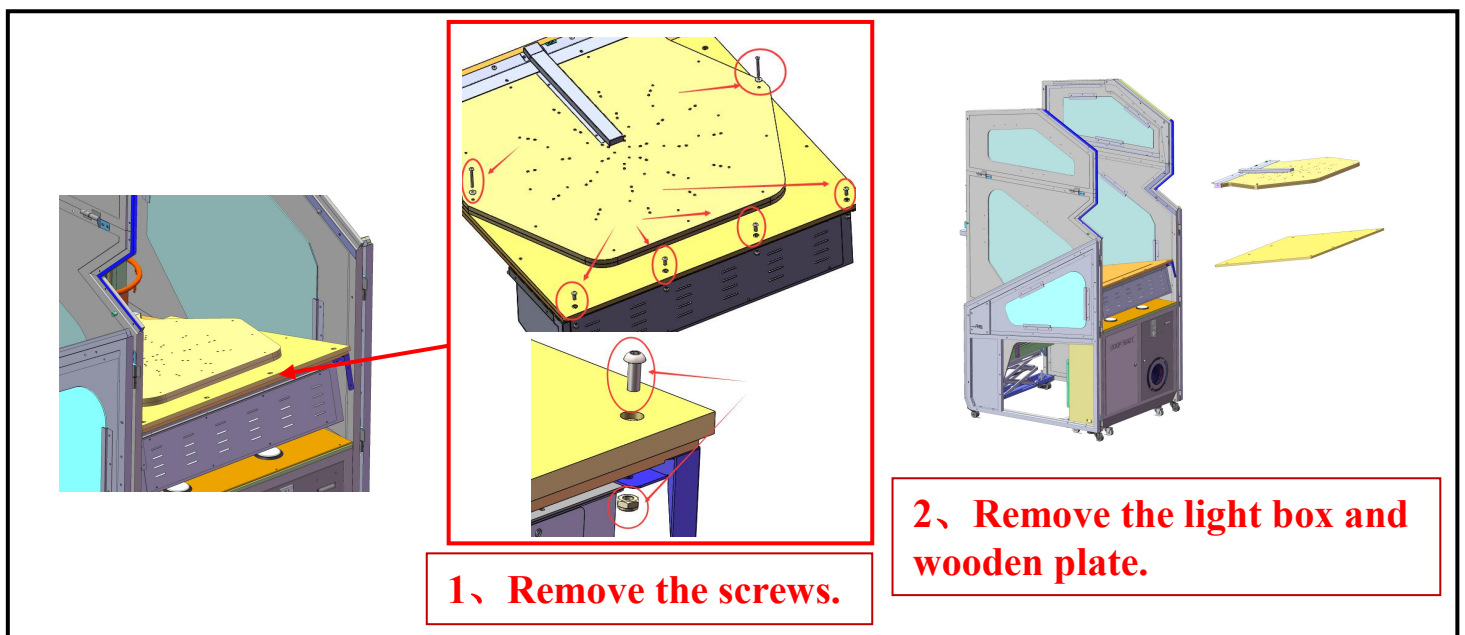

**4.** Remove the light box and wooden plate (2 screws on the left and right, 4 screws on the front).

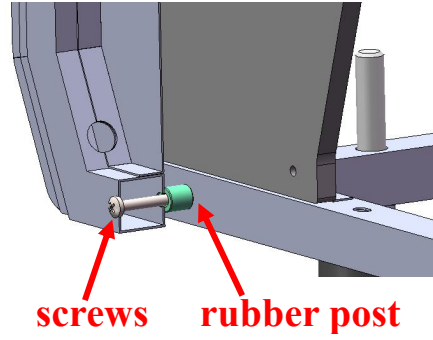
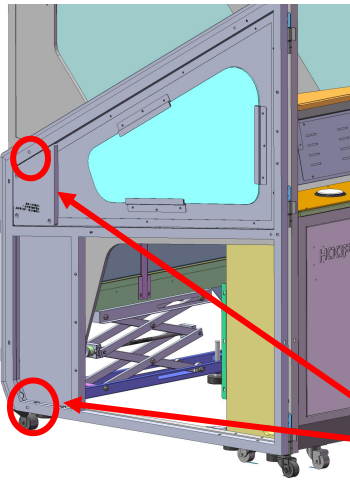

**Take out screws on both sides.**

**5.** Take out the screws and rubber posts that fix the side panels.

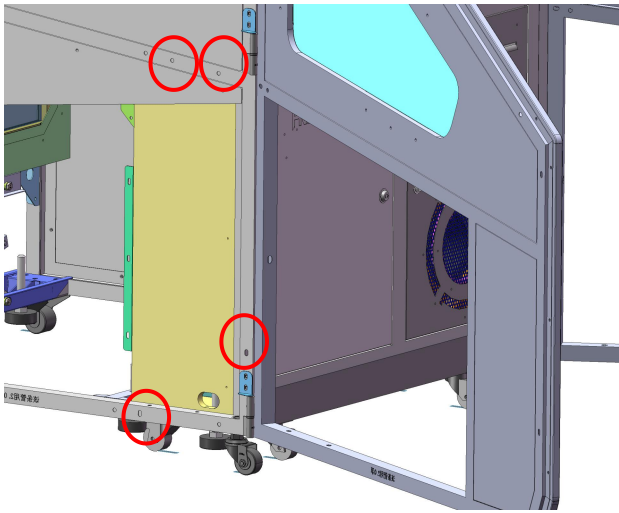

**1、 Take out screws on both sides.**

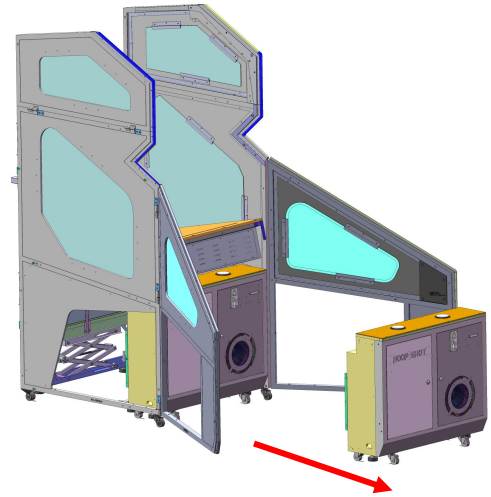

**2、 move out the entire console.**

**6.** Remove the screws (4 on each side) that fix the console, and slowly move out the entire console

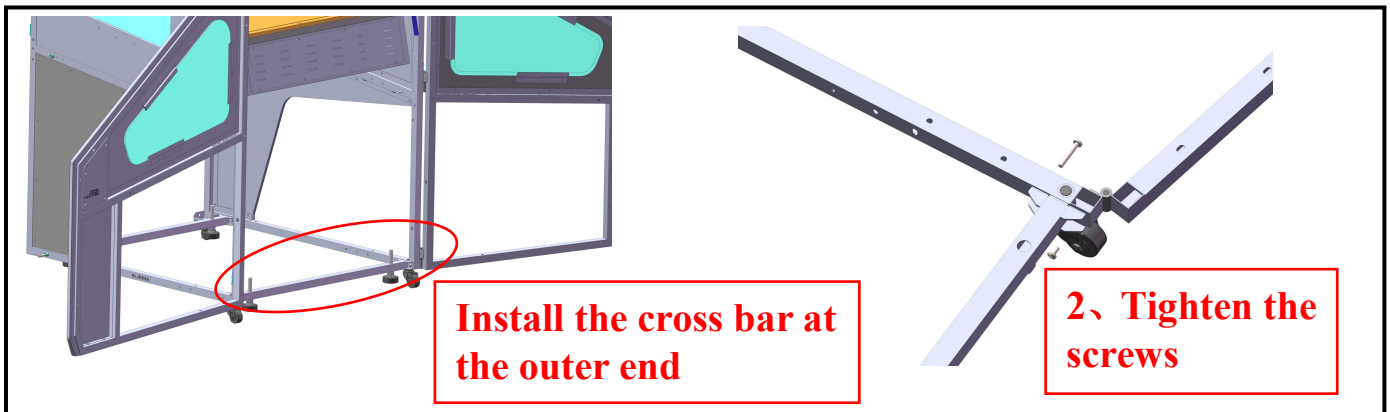
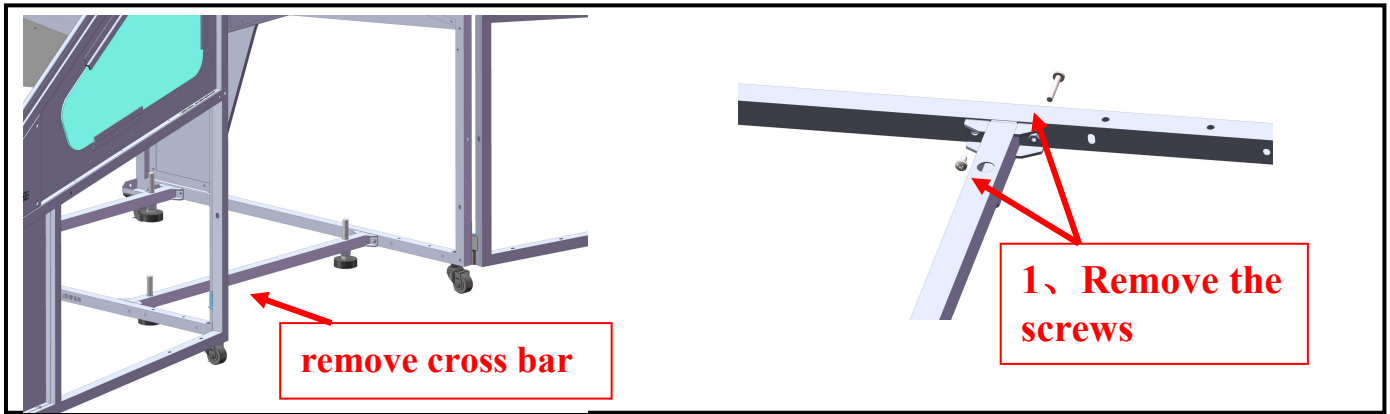

**7、** Remove the cross bar (2 screws on the left and right), rotate it 180 degrees horizontally and install it on the outer end.

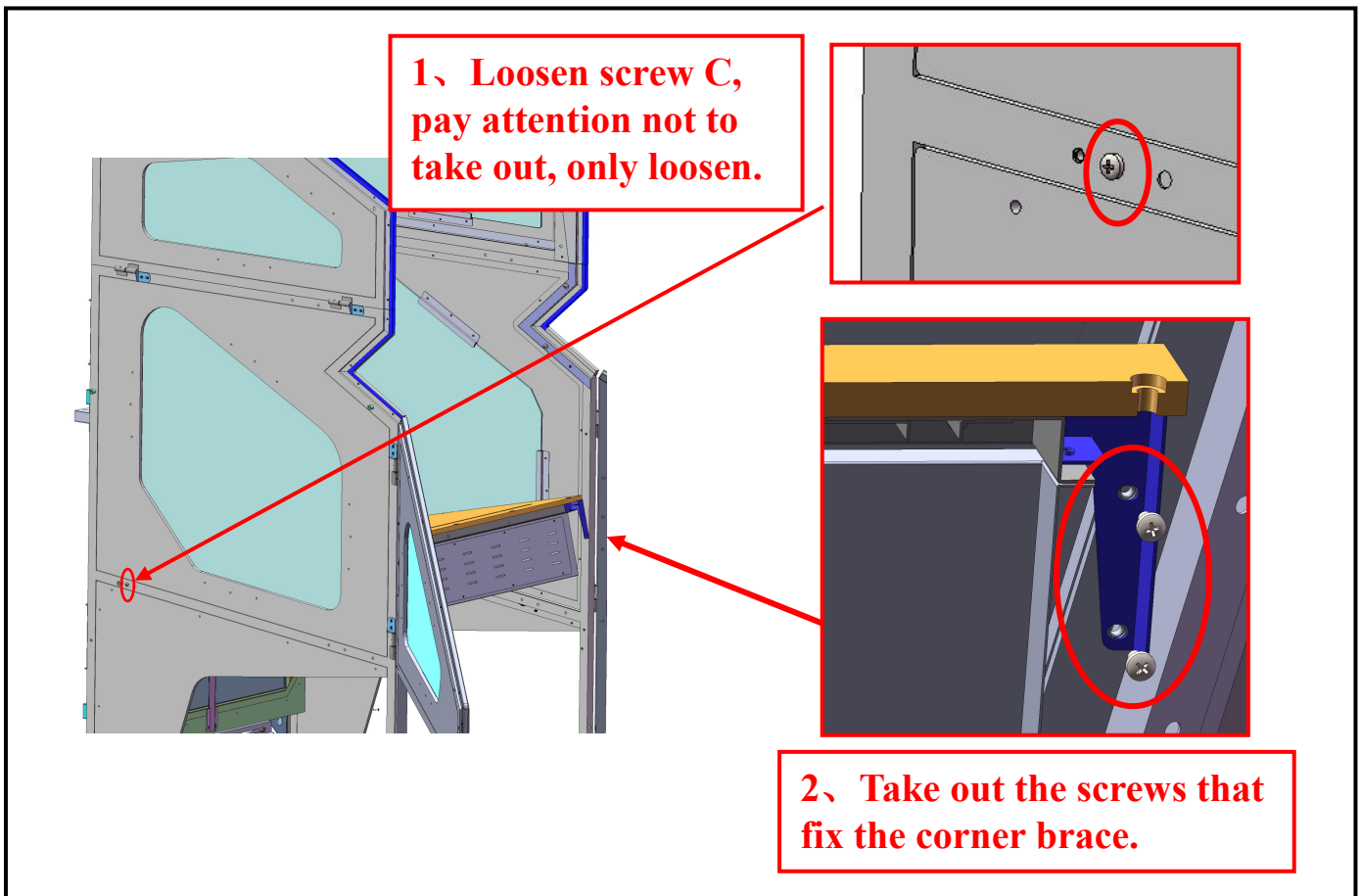

**8.1、** Loosen screw C, and then take out the screws that fix the corner brace. (2 screws on the left and right)

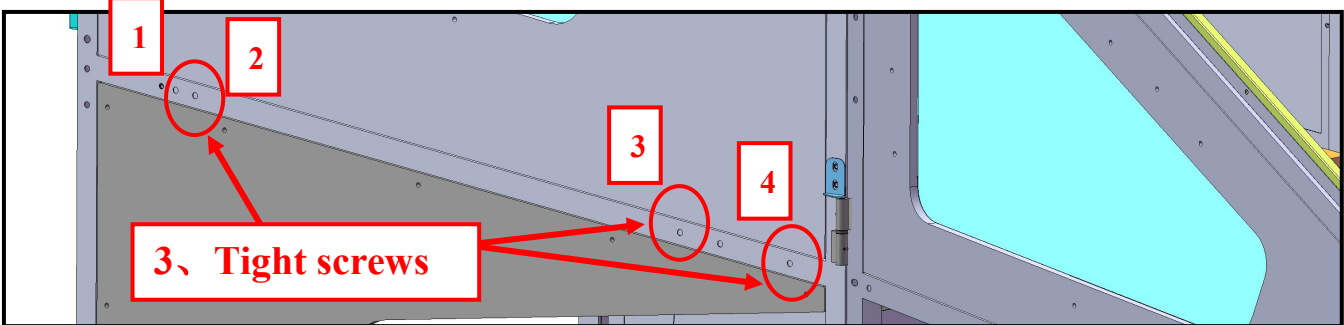
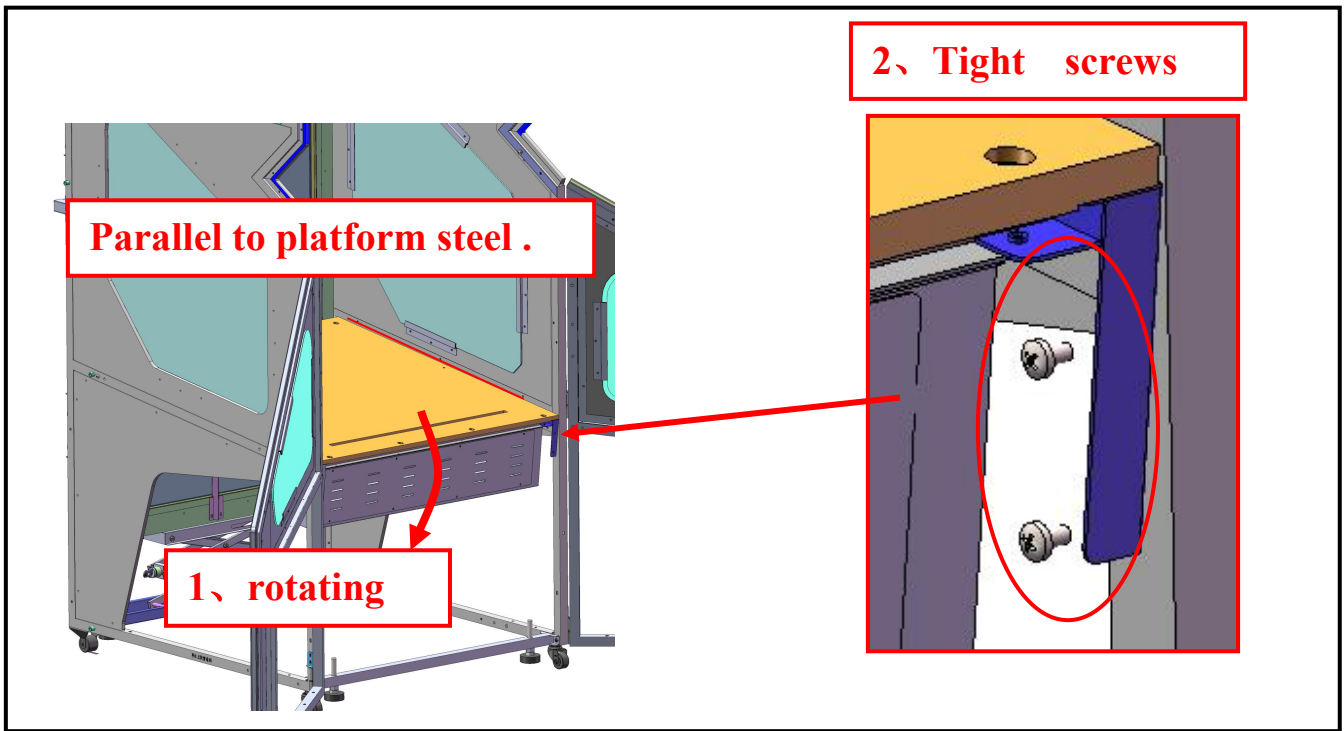

**8.2. Rotate the platform down. (Parallel to platform steel pipe) , re-fix the left and right corner hardware, and then tighten the screws on the side steel pipes (4 on each side).**

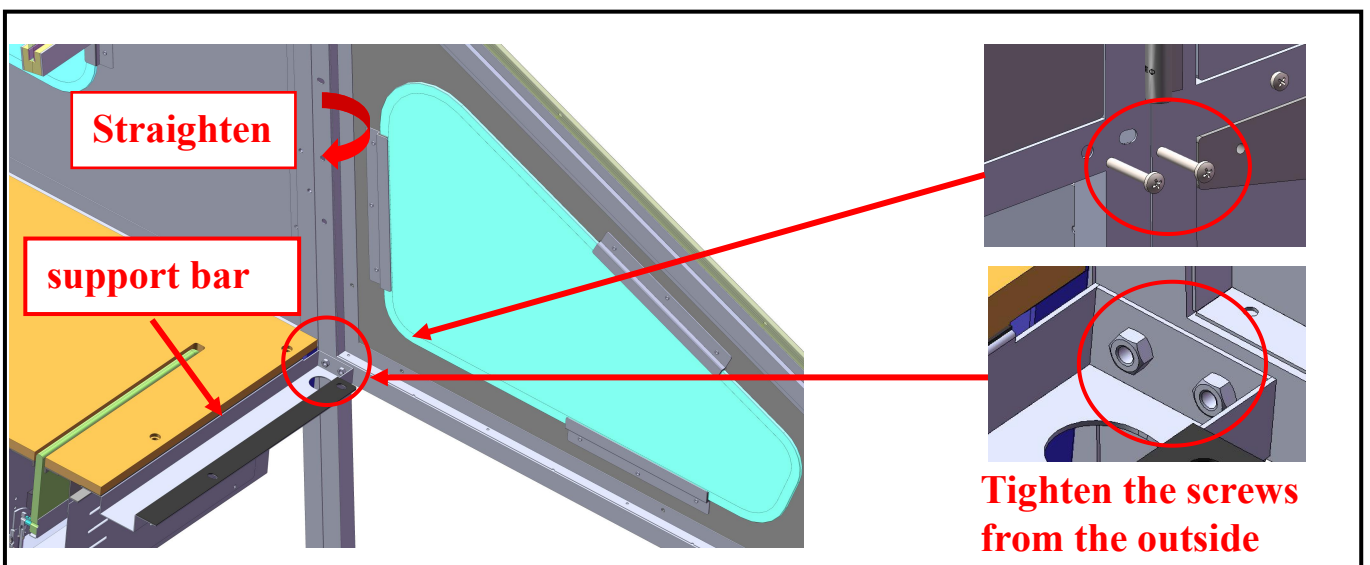

**9.1. Straighten the door panel, the support bar is placed at the joint, and tighten the screws from the outside (2 on each side).**

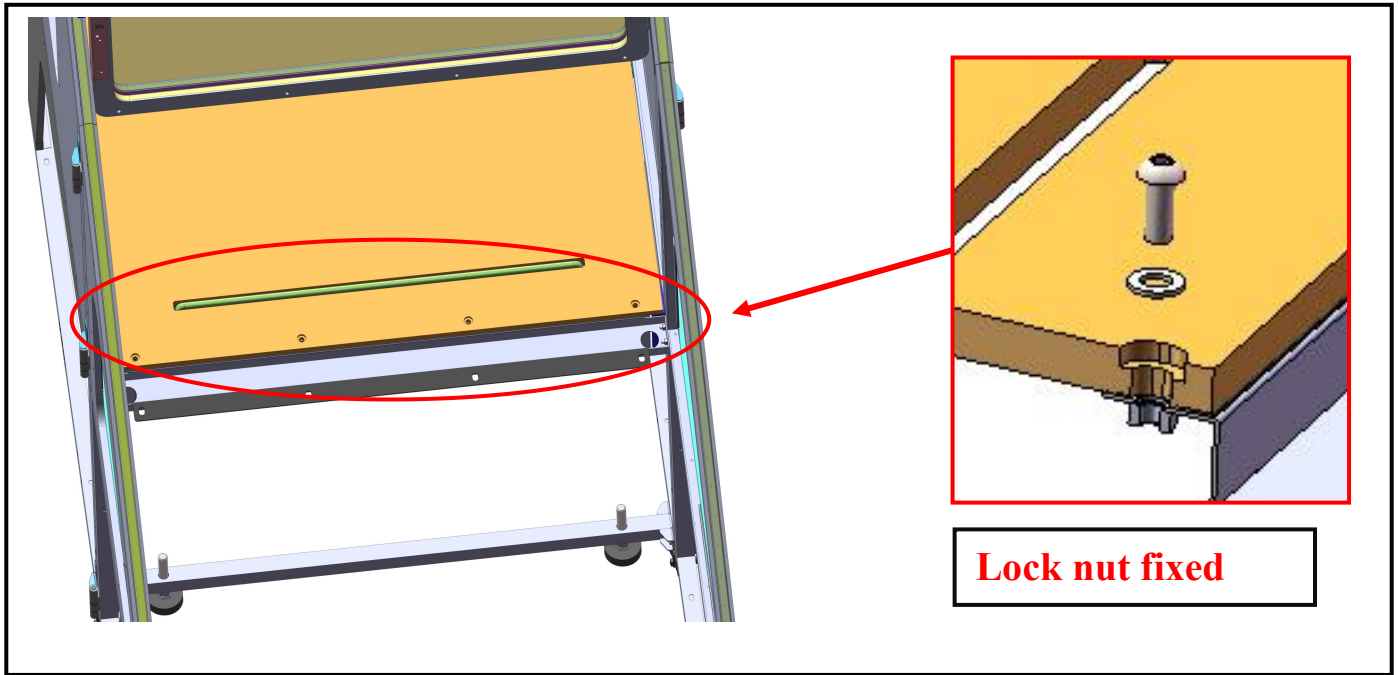

**9.2**、 Fix the platform board with 4 pcs M8 small flat head hexagon socket screws and washers in total.

**the opening of the metal buckle faces outward.**



**10**、 Take out the iron chain and hang it under the basket.(Note that the opening of the metal buckle faces outward)

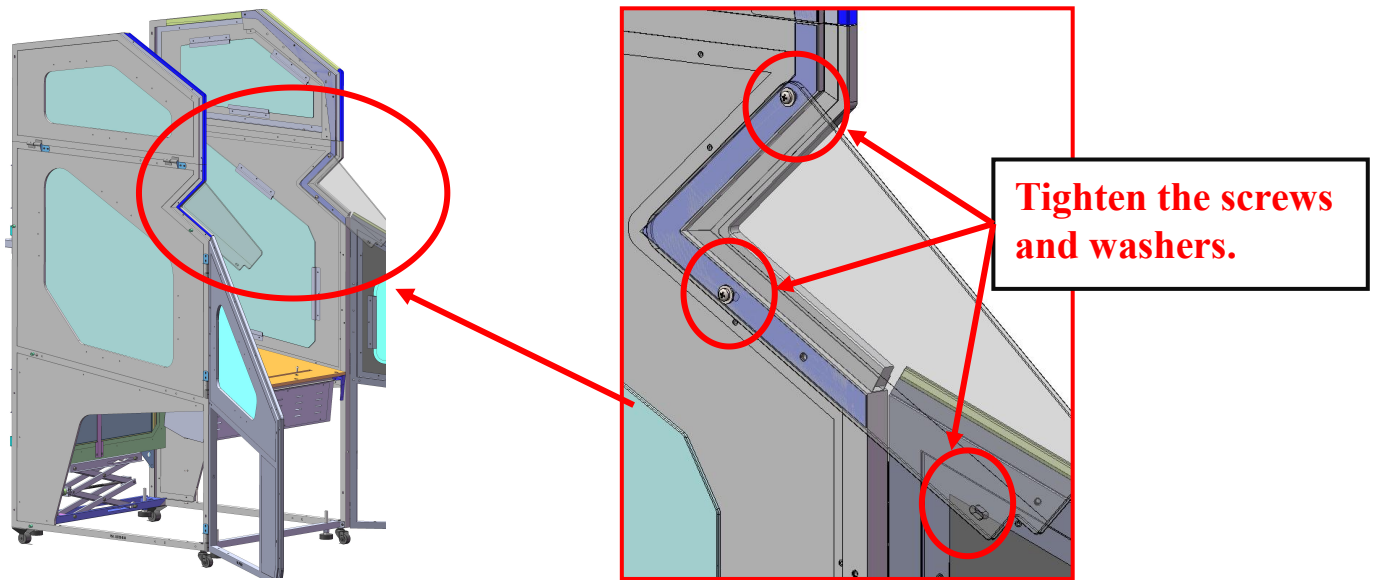

**11. Install two square acrylics on the left and right, 3 screws and washers for each.**

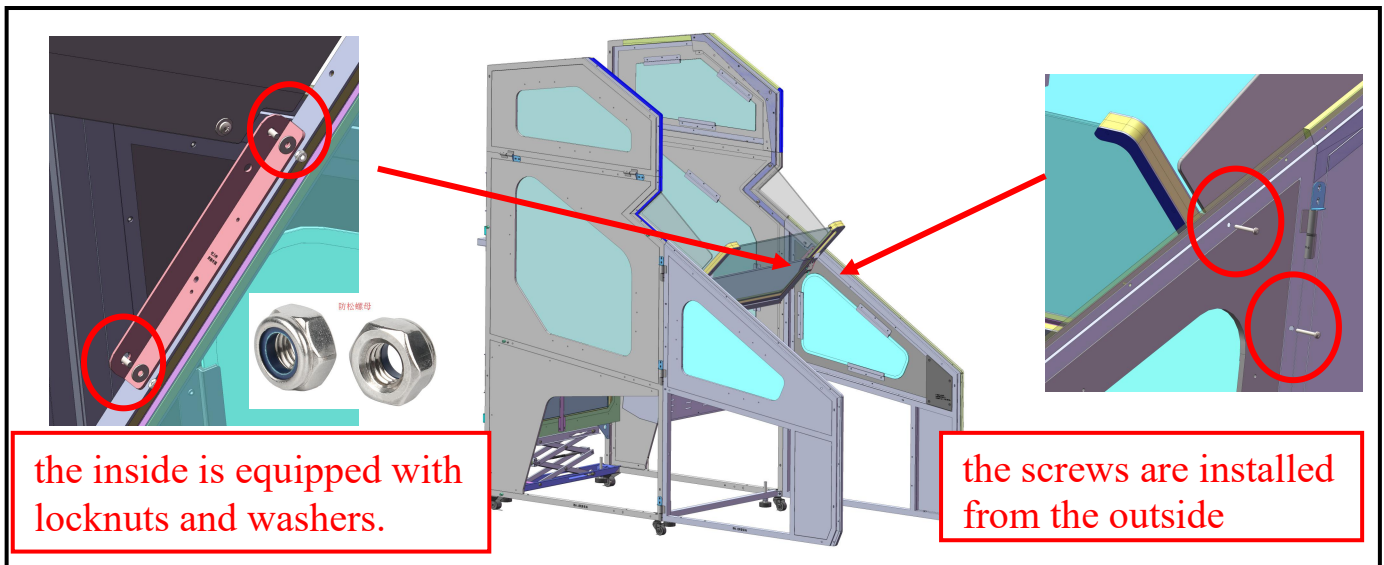

**12. Install the baffle glass, with the blue sticker facing the player, the screws are installed from the outside, and the inside is equipped with locknuts and washers (two on each side); do not tighten the screws.**

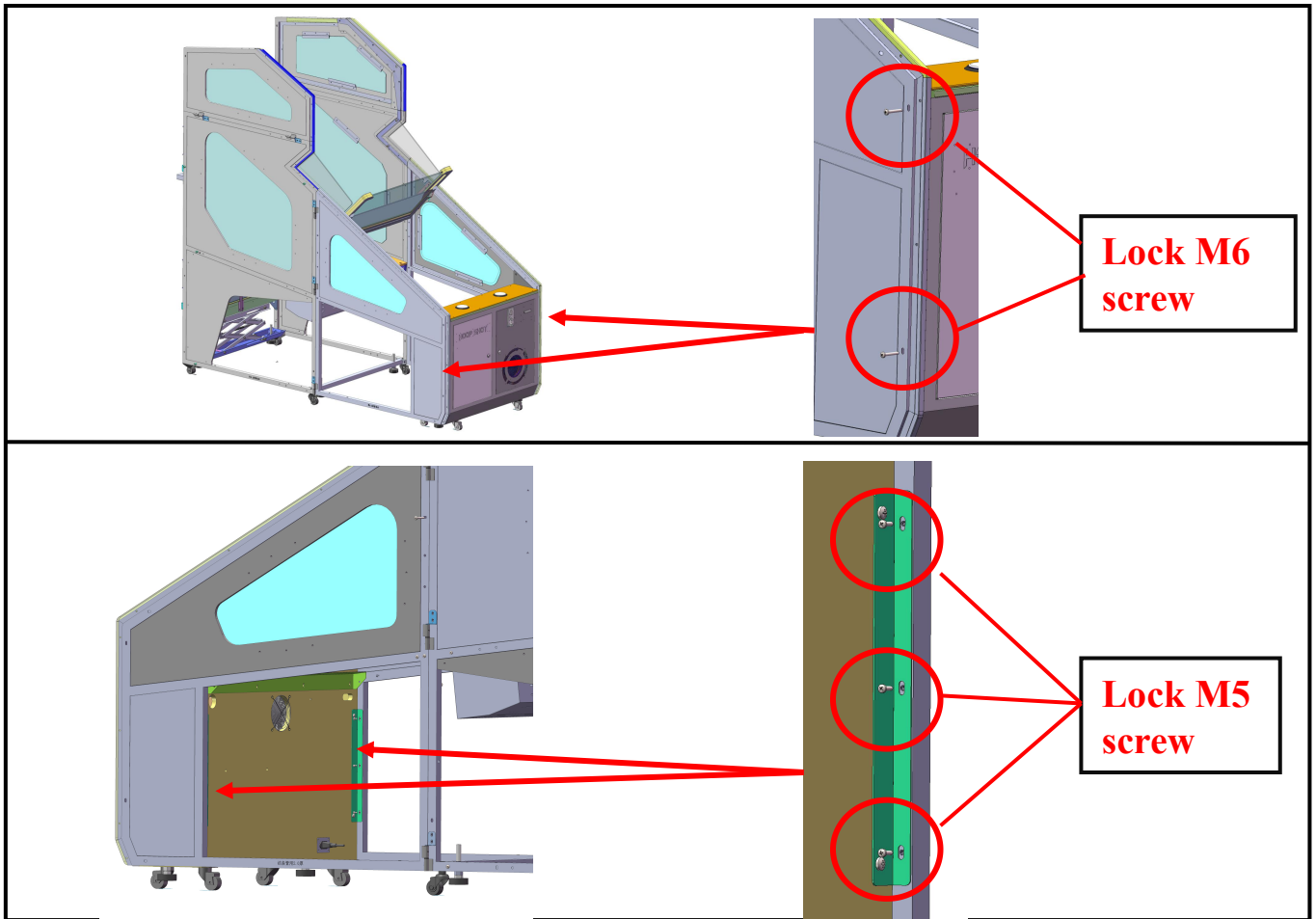

**13.1** Install the console, with 2 pcs M6 screws on the left and right, 3 pcs M5 screws on the left and right; M6 screws on the outside of the door, and M5 screws on the inside of the door behind the console. Note that there are light connectors on the sides of the door panels on both sides, which must be inserted into the console first. After installing the console, tighten the fixing screws of the baffle glass.

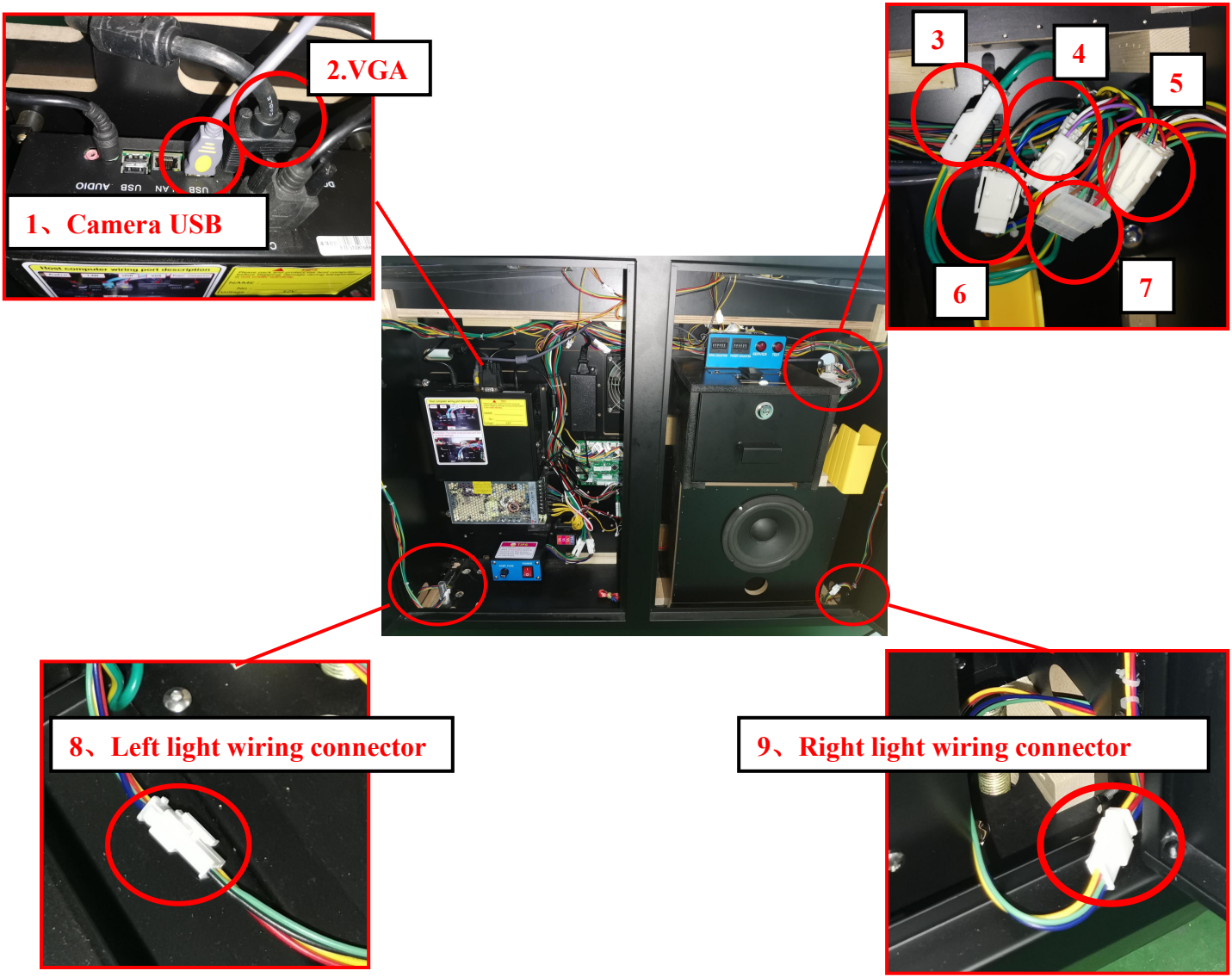

**13.2** After installing the console, open the left and right doors, plug connector 1, 2, and 3, 4, 5, 6, 7, 8, and 9 connector.

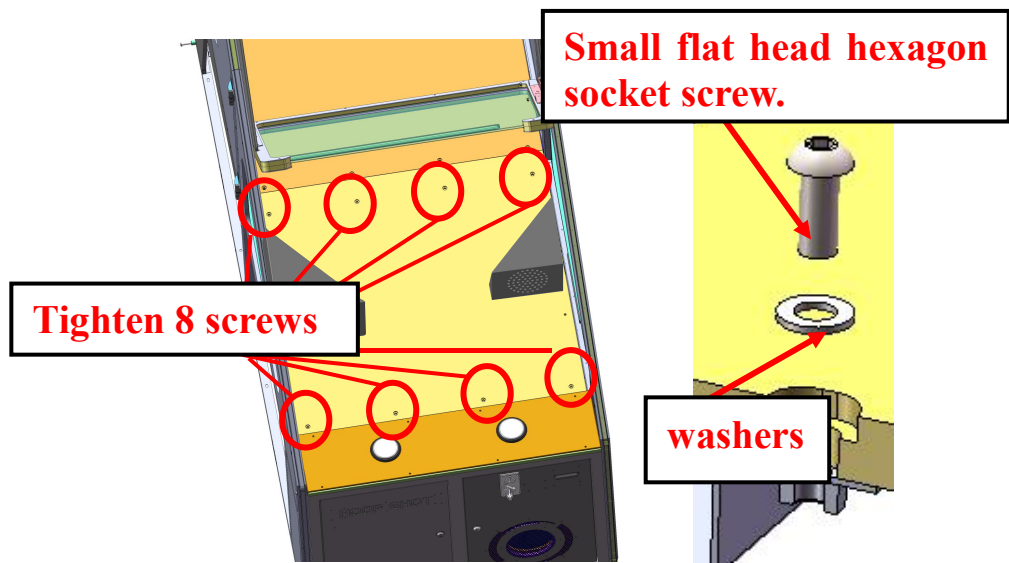

**14.1** Install the wooden plate behind the console, and lock it with M8 small flat-head hexagon screws and washers, a total of 8 pieces.



**Left and right speakers**



**Install the left and right speakers, tighten the screws.**



**14.2**、 Open the front door of the console, take out two speakers from the coin box, and install them on the wooden board behind the console. (Note that the connector of the speakers must pass through the wooden board). Connect the two speaker connector 1, 2 under the cabinet.

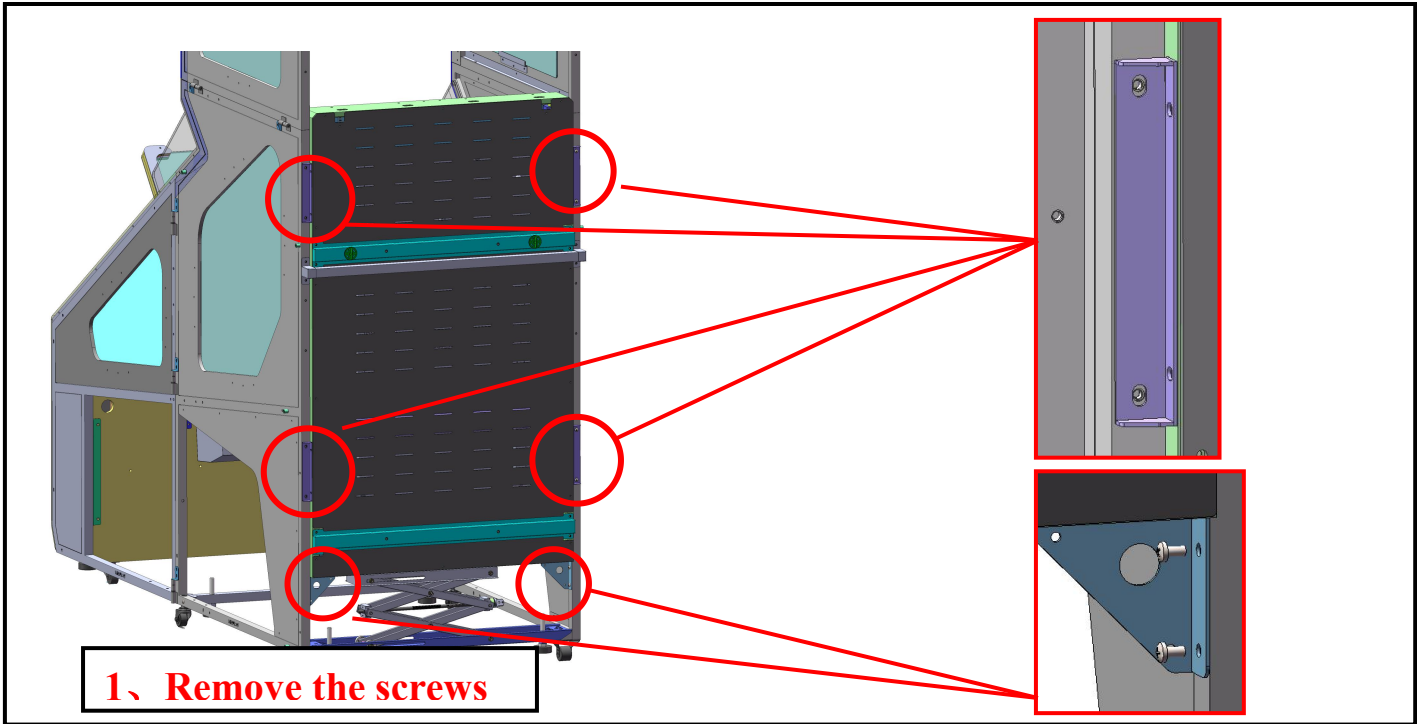

**1、 Remove the screws**

**15**、 First take out the 12 screws (6 on the left and right) that fix the screen frame.

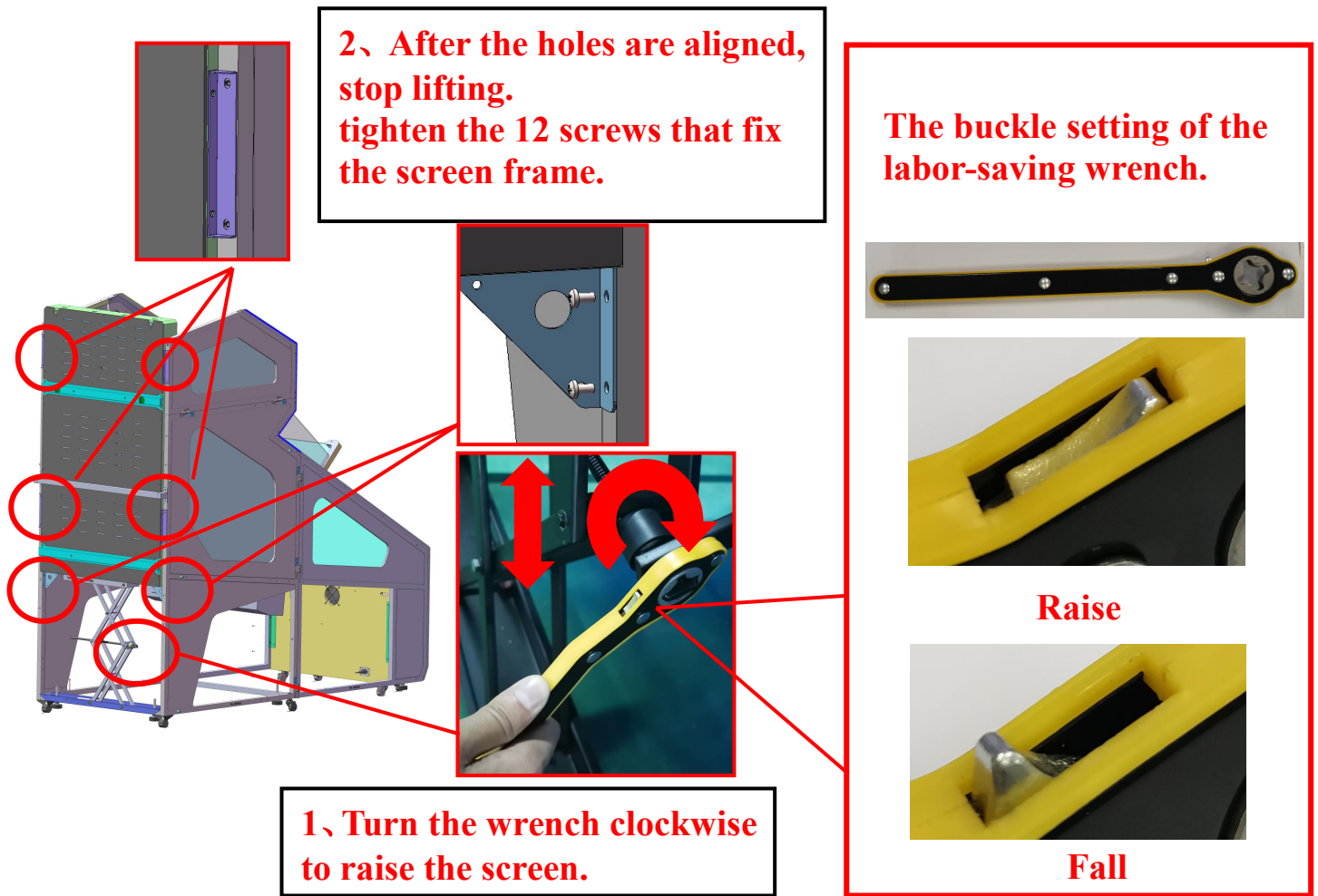

**16、 Adjust the buckle mode of the labor-saving wrench (as shown above). Turn the wrench clockwise to raise the screen to the specified position. tighten the 12 screws that fix the screen frame.**

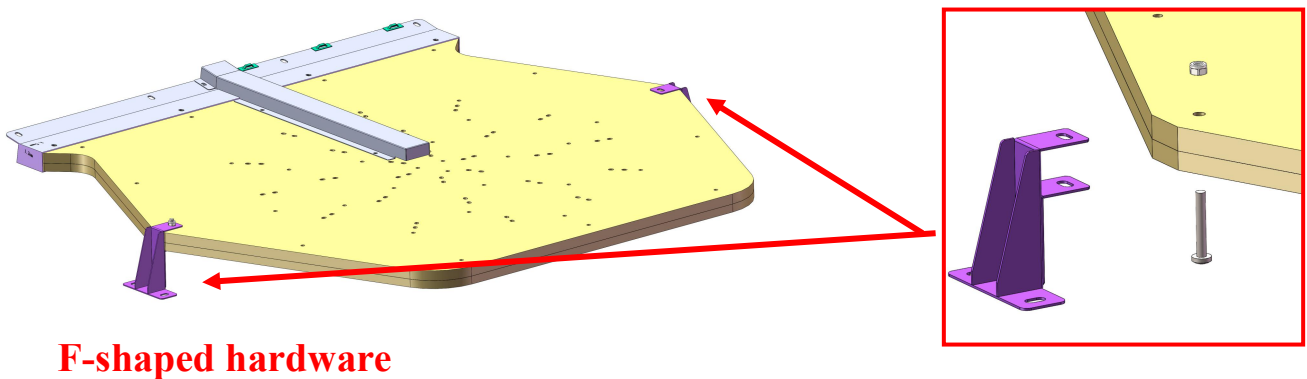

**17、 Install F-shaped hardware on both sides of the light box, with 1 screw on each side.**

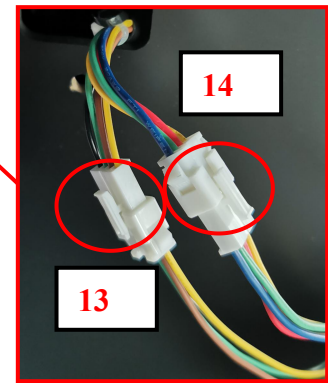
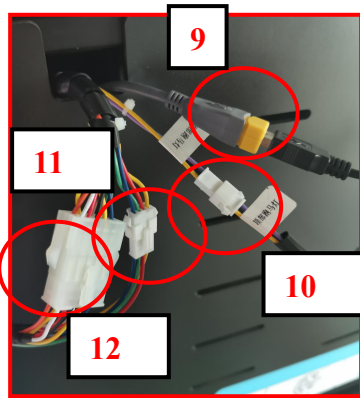
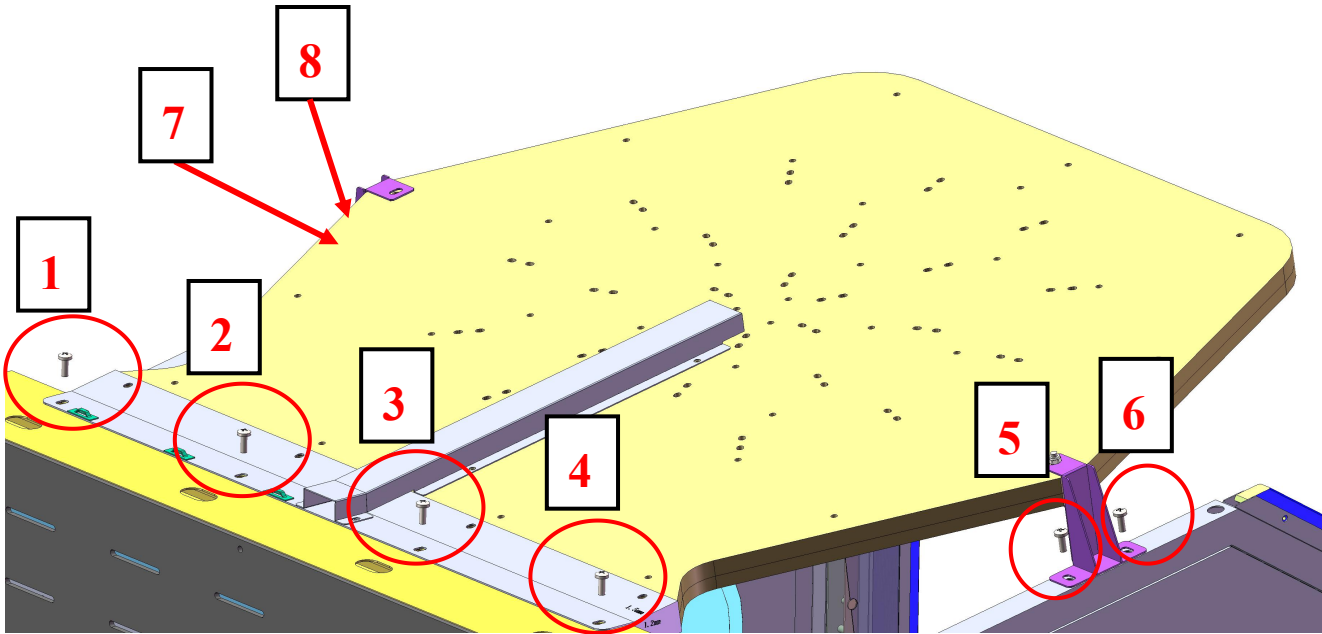

**18、** Fix the light box on the top of the screen with a total of 8 screws. Connect the 9 \ 10\11\12\13\14 wiring connector after connecting to the screen。

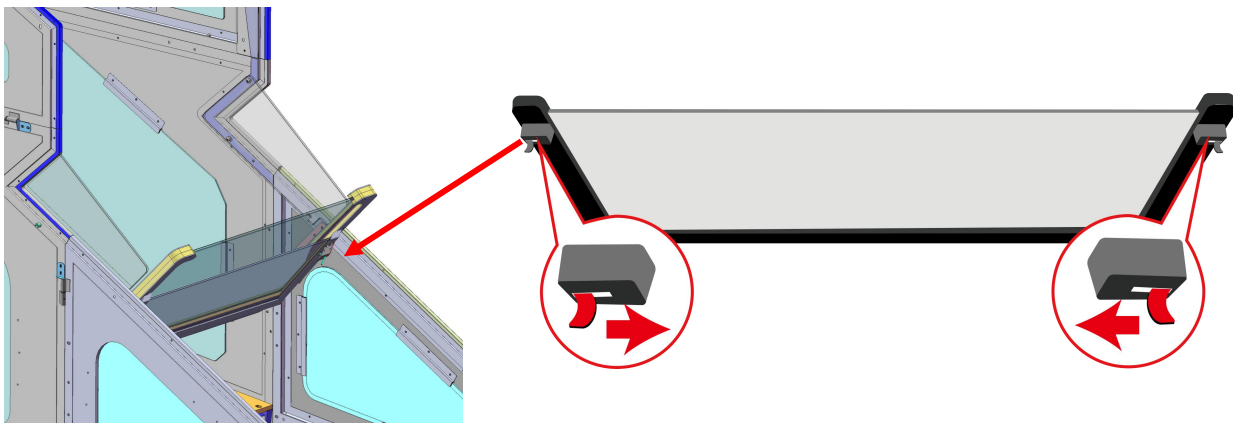

**19、** Hold the buckles on the left and right sides of the shelf, and push inwards at the same time, then gently lower the shelf.

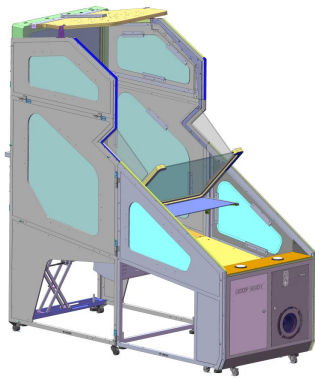

20、complete.

## 5. Inner Components

### 1、Screen components

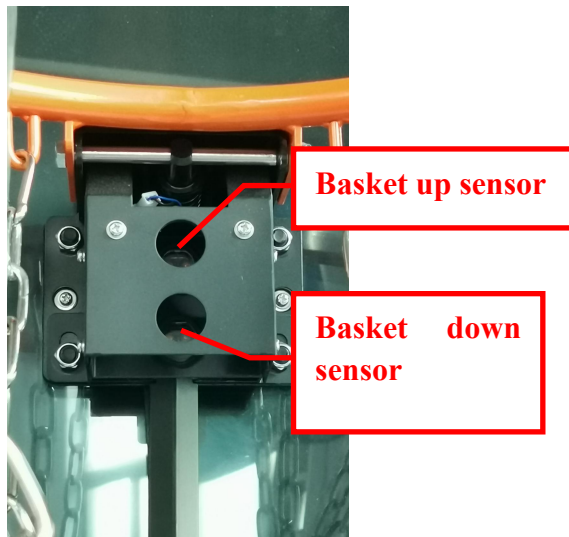

Side front sensor

## 2、 Main components inside the control console

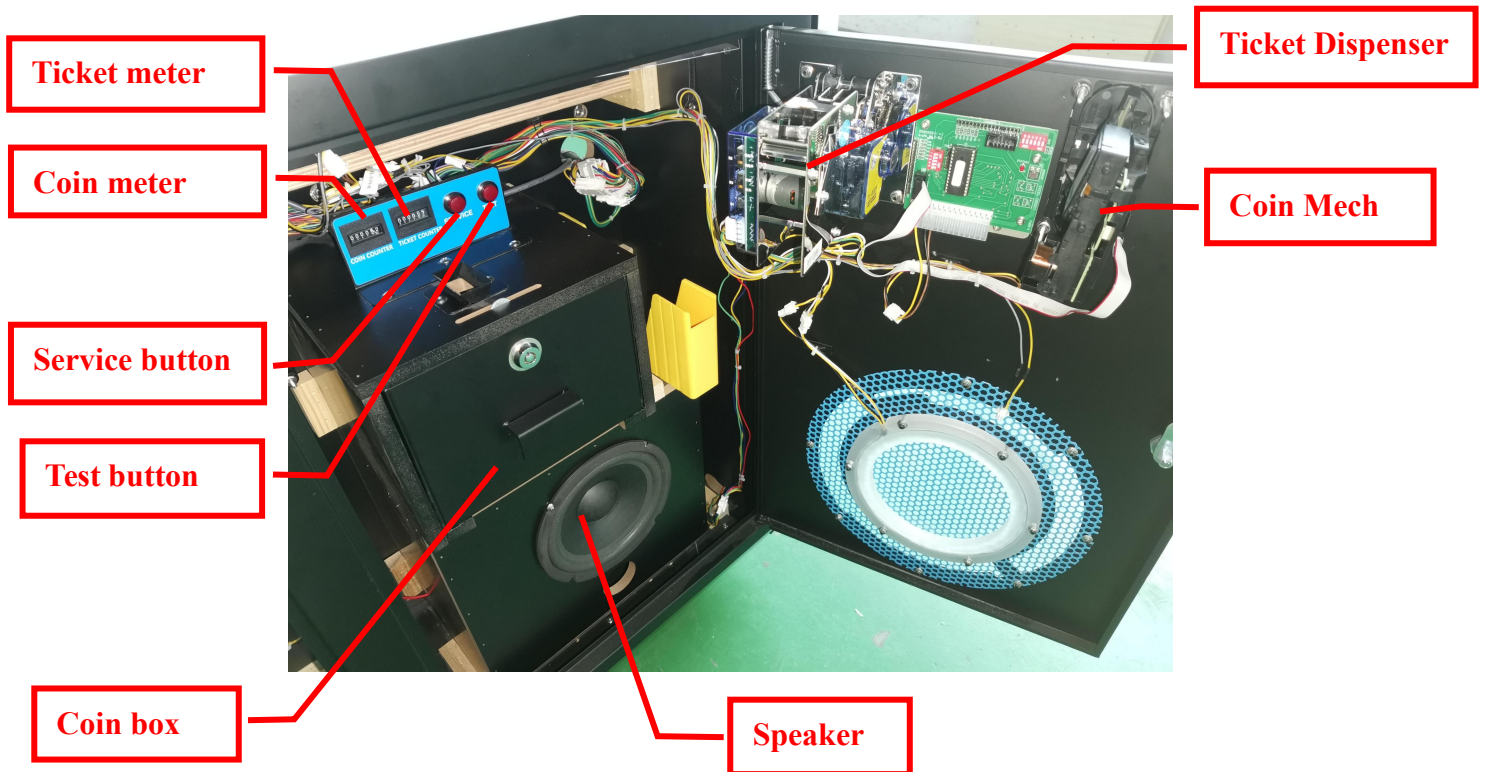
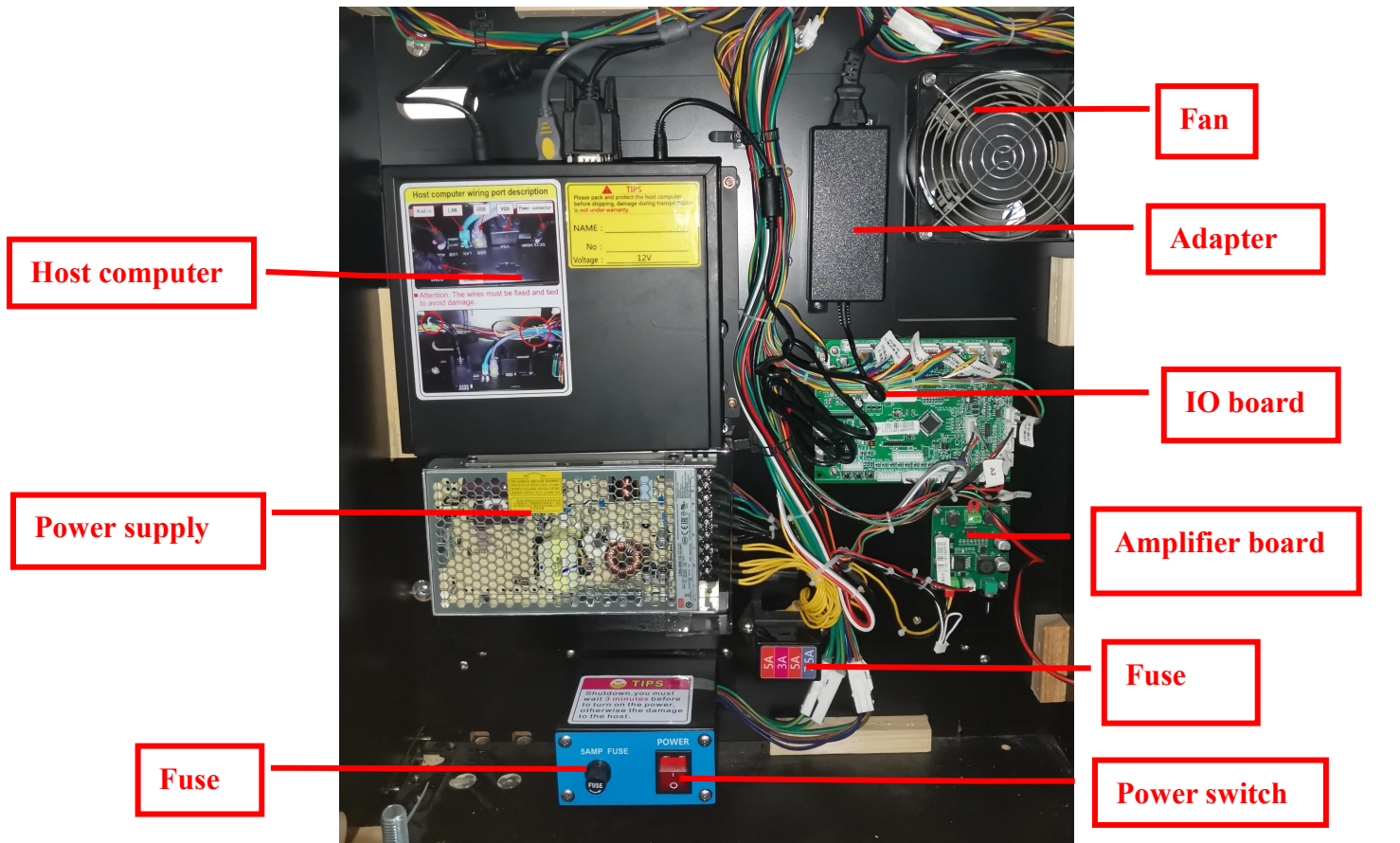

### 3、Components under the playfield

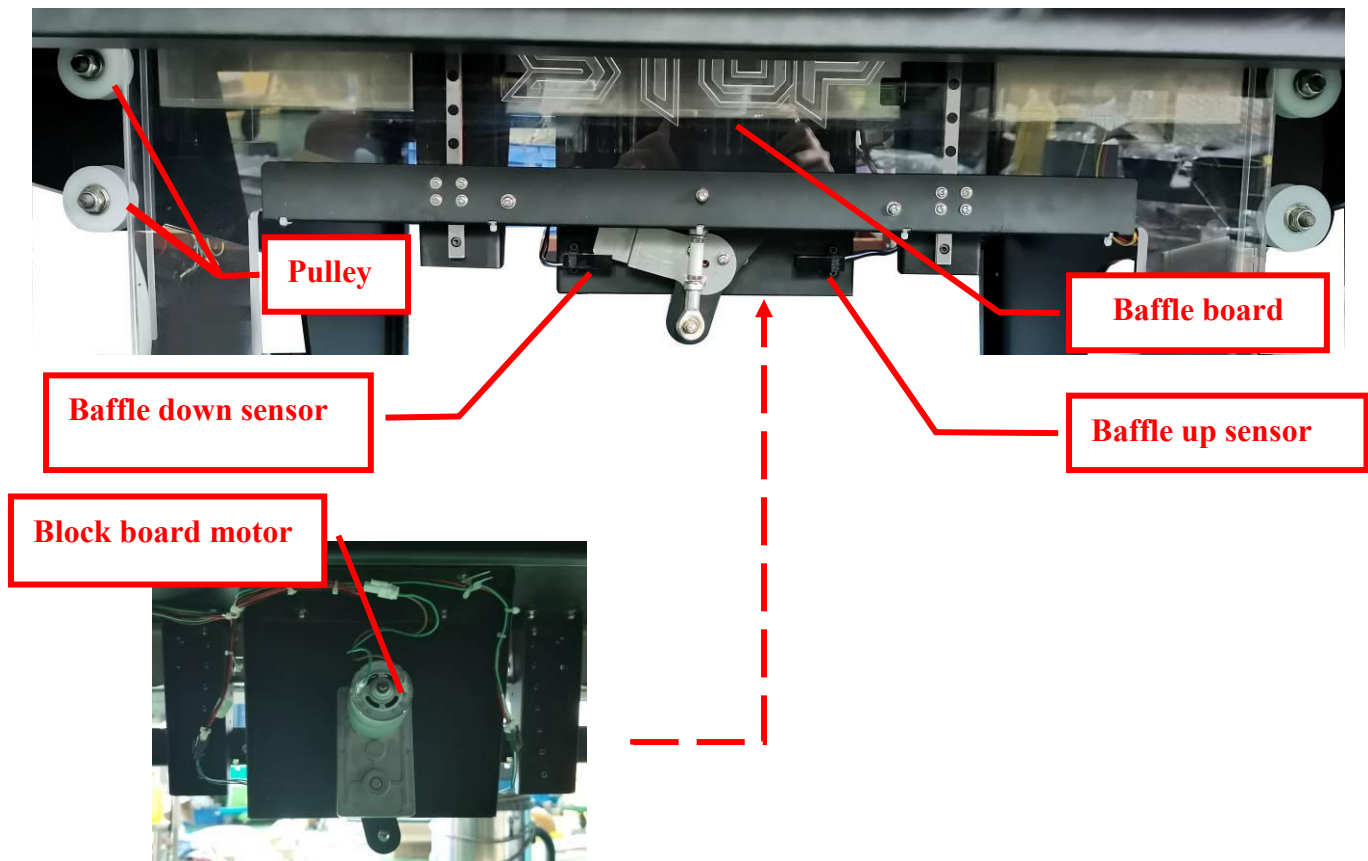

## 7. Game Setup

1. Press SERVICE button to enter the game setting menu

A) "Demo volume" The volume setting of the machine in the demo mode can be set to "0 ~ 1 0 0". This setting is set to the machine volume in the demo mode, the default is "50".

B) "Game volume" The volume setting of the machine in the play mode

C) "Coin assignments" : Coins-per-Play

D) "Points per ticket" If the prize mode is selected as lottery, when the game is over, the number of tickets the player will get which will be calculated based on the player's score divided by the current set value.

E) Game setting: Set the goal score, hit rate, and difficulty of the game in three modes: easy, hard, crazy. Set the game time and game difficulty.

F) "Current Plays" The current revenue of the machine can be cleared

G) "Total Plays" The total revenue of the machine can not be cleared.

H) "Total tickets" Total number of tickets the game has dispensed

I) "Update from USB" Insert the USB into the computer, and then press the "Test button" to start updating the game. Once updated, the game will reboot. DO NOT power off game while update is in progress or you will corrupt the drive.

J) "Internet update" Connect to internet for updating. (If available)

K) "I/O test" Enter hardware test screen.

L) "Clear current books" Clear the current statistics of the machine (number of tickets dispensed, coins inserted etc.

M) "Clear ranking" Clean the current ranking data

N) "QR code login" You can choose "ON or OFF". When the setting is "ON", the QR code login will appear when the game starts.

O) “Competition rankings waiting” : When this option is set to (off), the ranking will automatically exit after 30 seconds, and when the option is set to (on), the ranking screen will remain. Press the start button or select button to exit the ranking screen.

P) 1 minute goals reward mode: When set to ON, it will directly enter the 1 minute Goals mode after game start, When set to OFF, it will return to the normal mode.

Q) 1 minute goals reward: Set how many balls the player hits within 1 minute to get rewards.

Q) “Default setting” Restore to factory settings

R) “Exit without save” Cancel setting and exit.

S) “Exit with save” Save setting and exit.

Press the SERVICE button to move the blue mark up and down, press the TEST button to confirm.

MAIN MENU		Value Range	Default
DEMO VOLUME		0-100	50
GAME VOLUME		0-100	100
1 CREDIT COIN		0-10	3
2 CREDIT COIN		0-11	5
POINTS PER TICKET		0-500	50
1 MINUTE GOALS REWARD		10-150	10
GAME SETTINGS		Value Range	Default
Single	LEVEL 1	30s-60s	40s
	LEVEL 2	30s-60s	40s
	LEVEL 3	30s-60s	40s
	LEVEL 4	30s-60s	40s
multiplayer	ROUND 1	30s-60s	40s
	ROUND 2	30s-60s	40s
	ROUND 3	30s-60s	40s
EASY	LEVEL 1 TARGET SCORE	5 — 500	20
	LEVEL 2 HIT RATE	5% — 100%	20%
	LEVEL 3 DIFFICULTY	1 — 15	1
	LEVEL 4 TARGET SCORE	5 — 5000	580
HARD	LEVEL 1 TARGET SCORE	5 — 1000	50
	LEVEL 2 HIT RATE	5% — 100%	30%
	LEVEL 3 DIFFICULTY	1 — 15	2
	LEVEL 4 TARGET SCORE	5 — 5000	1800
CRAZY	LEVEL 1 TARGET SCORE	5 — 1500	200
	LEVEL 2 HIT RATE	5% — 100%	70%
	LEVEL 3 DIFFICULTY	1 — 15	4
	LEVEL 4 TARGET SCORE	5 — 5000	2600

## 2. I/O test

Enter the I/O test interface, press any hardware that needs to be tested (such as START button, SERVICE button, TEST button), the corresponding hardware status on the screen will turn red ON, and release it will turn back to white OFF. If the button is pressed, the corresponding status on the screen will not change. It means that the corresponding hardware is faulty. Press the SERVICE button and TEST button at the same time to exit the I/O test.

Note:

Hit sensor: Shoot the ball or block the hit sensor area. When the ball passes through the area, it will turn to red ON.

Baffle test: After entering the baffle test, press Start button to rise the baffle, and the status of baffle up sensor turns to red ON; Press Select button to descend the baffle. At this time, the status of baffle down sensor turns to red ON;

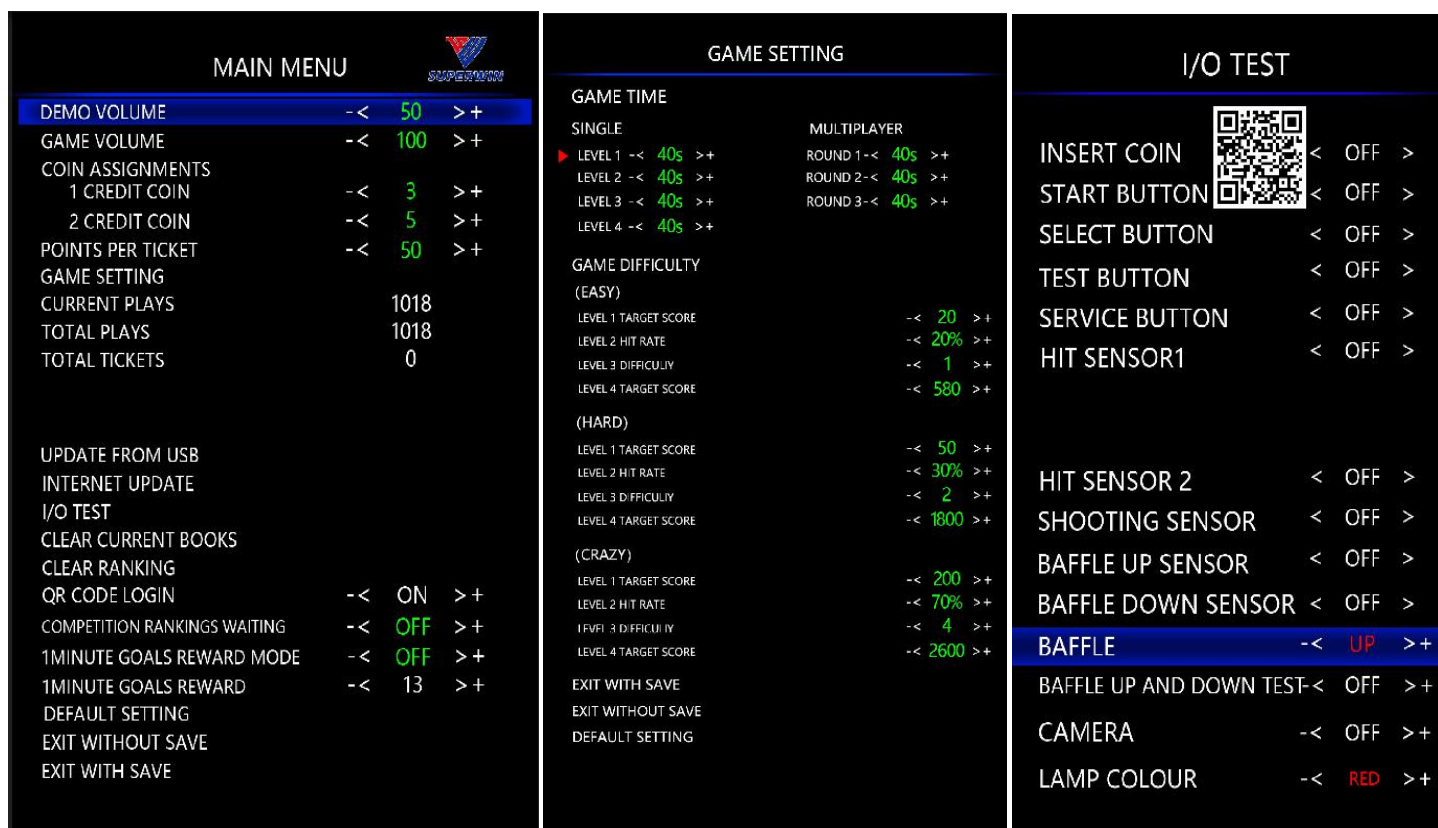

Main Menu

GAME STTING

I/O test

## 8. Game Play

1. After the hardware check is completed, the game starts loading, then the game enter demo mode.

2. Insert coin, press the START button to start the game. Player chooses to scan and log in by scanning the QR code. Or press the START button to skip login; and then press the START button to take a photo.

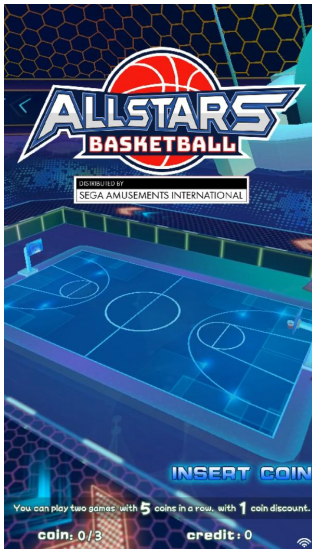

Scan QR code to log in

Take a player portrait

### 3. Single player

Players choose single player, and then choose the difficulty of the game. Press the START button to start playing.

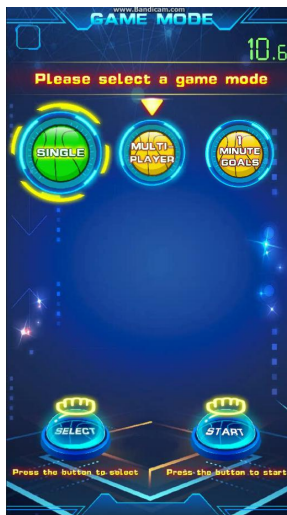

Choose single player

Choose the difficulty

3.1. The game screens of 4 missions as shown below:

Mission 1: Reach the target score to pass the game.

Mission 2: Reach the target hit rate to pass the game.

Mission 3: Continuous shooting, when the point is full, you can get a medal.

Mission 4: Reach the target score to pass the game.



Mission 1



Mission 2



Mission 3



Mission 4

3.2. The challenge is successful, enter the next mission of the game. After the game is over, score rankings.



#### 4. Multi-player PK

players select Multi-player game mode at the same time, press the start button, and wait for players to join. Choose three competition items and press the start button to start the game. The winner is the best of three games.

PK mode

3-Point shot: The player who gets the most 3 points wins!

PK: The game start energy each half, fast goal growth energy surpasses the other side to win!

Combo: The player with the highest number of combo wins!

Hit rate: Throw 100 balls, the player with the highest hit rate wins!

Total shot: The player who throws the most balls wins!

Total score: The player with the highest score wins



## 9. Troubleshooting guide

SYMPTOM	POSSIBLE CAUSES / ACTIONS
A. Host computer doesn' t work	Check host computer has power and if the fuse blowout.
B. No sounds	1, Check for audio cable communication on host computer, Check for amplifier board power, Check potentiometer is working. 2, Check connection is ok Check the speaker is ok.
C. Cannot start the game	Check START button is ok Check connection is ok Check I/O board is working

D. No signal	Check connection is ok or host computer is working.
E. Side back sensor error	1、 Check communication connector on side back sensor. Or sensor is blocked by something. 2、 A failure of this sensor will be reflected as an error.
F. Side front sensor error	1、 Check communication connector on side front sensor. Or sensor is blocked by something. 2、 A failure of this sensor will be reflected as an error.
G. Baffle down sensor error	1、 Check communication connector on baffle down sensor. Or sensor is blocked by something. 2、 A failure of this sensor will be reflected as an error.
H. Baffle up sensor error	1、 Check communication connector on baffle up sensor. Or sensor is blocked by something. 2、 A failure of this sensor will be reflected as an error.
I. Basket down sensor error	1、 Check communication connector on basket down sensor. Or sensor is blocked by something. 2、 A failure of this sensor will be reflected as an error.
J. Basket up sensor error	1、 Check communication connector on basket up sensor. Or sensor is blocked by something. 2、 A failure of this sensor will be reflected as an error.
K. Baffle motor error	1、 Check communication connector on baffle motor or if motor is working. 2、 Check communication connector on basket up/down sensor.
L. I/O board disconnected, please check	Check communication connector on I/O board.
M. Coin Tech error	1、 Check coin mech switch is ok Check communication connector on coin mech. 2、 Check I/O board is working. 3、 Check coin mech ID-switch setting, as ON status

# 10. Allstars Basketball---Wearing Parts list

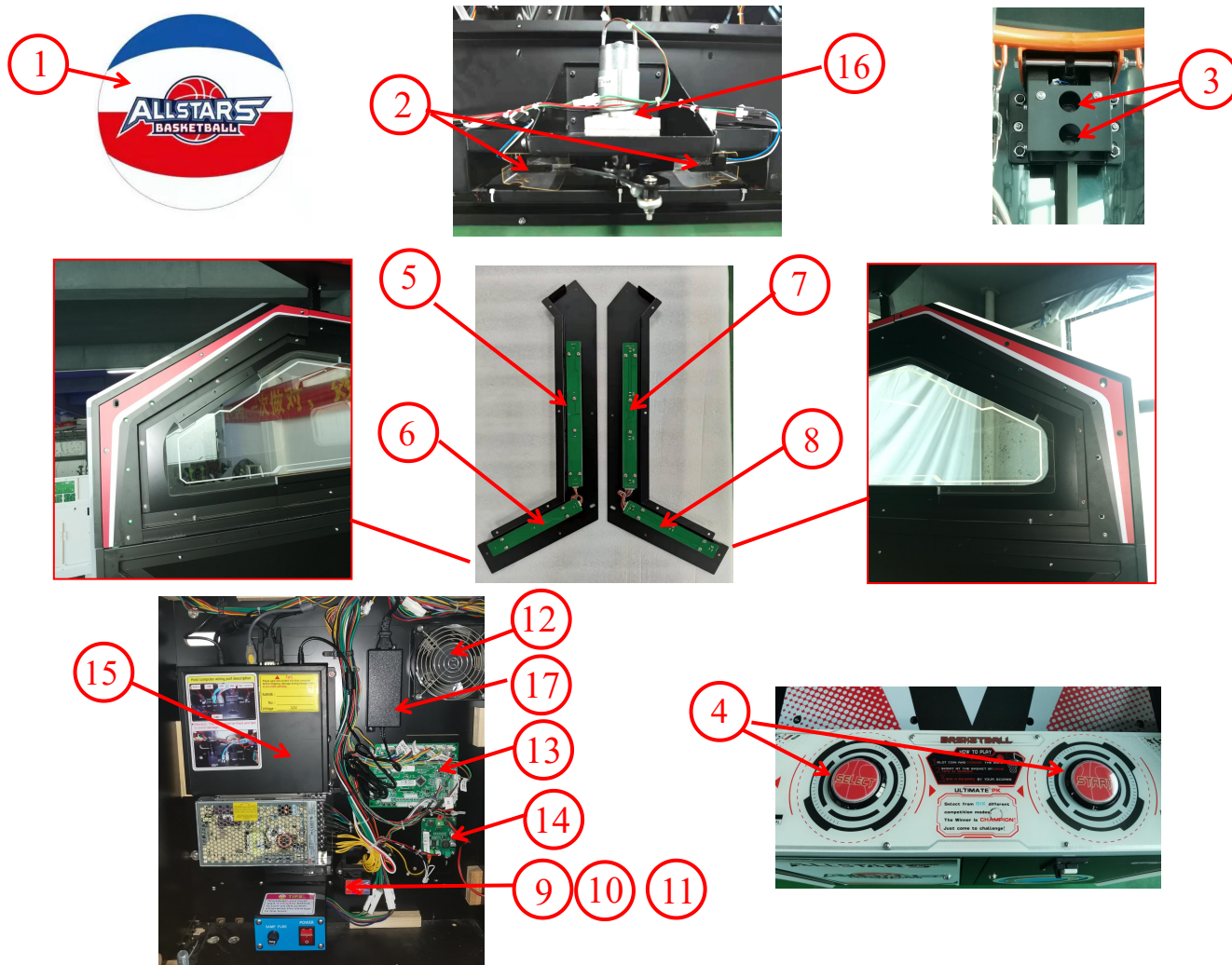

No.	Product code	Name	Qty	Remarks
1	1.SL.YZ.0146	Ball		
2	1.DZ.DQ.0295	Baffle sensor	2	
3	1.DZ.DQ.0377	Basket sensor	2	
4	1.DZ.KG.2112	Start Button ,Select Button	1 each	
5	2.XB.ET.0095	Basketball transmitter board (UP)	1	
6	2.XB.ET.0096	Basketball transmitter board (down)	1	
7	2.XB.ET.0097	Basketball receiver board (UP)	1	
8	2.XB.ET.0098	Basketball receiver board (down)	1	
9	1.DZ.QT.0041	3A Fuse	1	
10	1.DZ.QT.0050	5A Fuse	1	
11	1.DZ.QT.0052	7.5A Fuse	1	
12	1.DZ.FS.2002	Fan	1	
13	2.XB.ET.0011	IO board	1	
14	1.DZ.XB.0155	AMP	1	
15	2.ZJ.YZ.0054	Computer host	1	
16	9.DZ.DJ.0026	Baffle motor	1	
17	1.DZ.DY.0133	Adapter	1	

# 11. Caution & Warning Stickers

**WARNING**

High voltage can cause an electric shock. Turn off power before servicing.

**ATTENTION**

- The machine for indoor use, can not be placed in direct sunlight, near passage, stove or 30 temperature, import and export, the local, and other special requirements.
- By the machine around from place to place walls, machines, activities of electric and personal passageway must be maintained or at least 50cm distance.
- The back of the machine may emit hot air with vent, so can not to place flammable liquids, otherwise likely to cause fire.
- The back of the machine vent for the motherboard and image tube of hot air, can not be placed on flammable liquids at the vent, otherwise likely to cause the flame.

**Warning symbol** don't open the door (for staffs only)

← Remove the fixing screws →

Remove the fixing screws

Remove the fixing screws

**Warm prompt**  
Before turning the rocker, please remove the fixing screws on the left and right sides of the screen.  
(A total of 12 fixing screws)

**Labor-saving wrench instructions**

- Get the handle into the screw hole.
- Put the wrench on the positive shaft.
- Turn the wrench clockwise to rotate the screw.
- The screw is rotated.

**WARNING**  
Mind your hands.

holder position

**CAUTION**  
DO NOT ENTER

**CERTIFICATE OF INSPECTION**

Product Name: ALLSTARS BASKETBALL  
 Certificate No.: (2020) 52  
 Product Serial No.: ET061S

Inspector: Guangzhou Supervising Animation Technology CO.LTD

SUPERWING ANIMATION TECHNOLOGY CO.,LTD  
 NAME:ALLSTARS BASKETBALL MAX POWER: 600W  
 MODEL: ET061S MIN POWER: 540W  
 S/N: FREQUENCY: 50-60Hz  
 VOLTAGE: 220V DATE :  
 INDOOR MACHINE RoHS

**DANGER**

220V High voltage

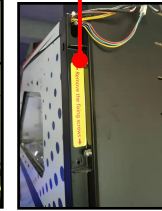
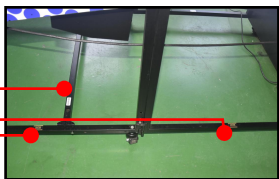
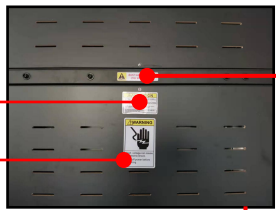

Remove the fixing screws

holder position

**CAUTION**  
DO NOT ENTER

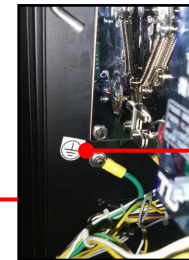
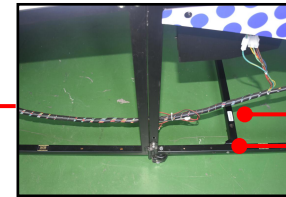

**Host computer wiring port description**

Attention: The wires must be fixed and tied to avoid damage.

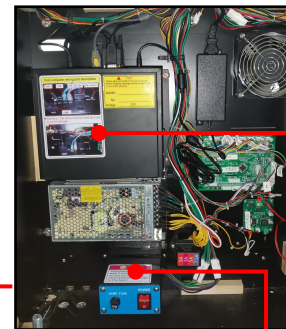

**TIPS**

Shutdown, you must wait **3 minutes** before to turn on the power, otherwise the damage to the host.

# 12. Wire Dia

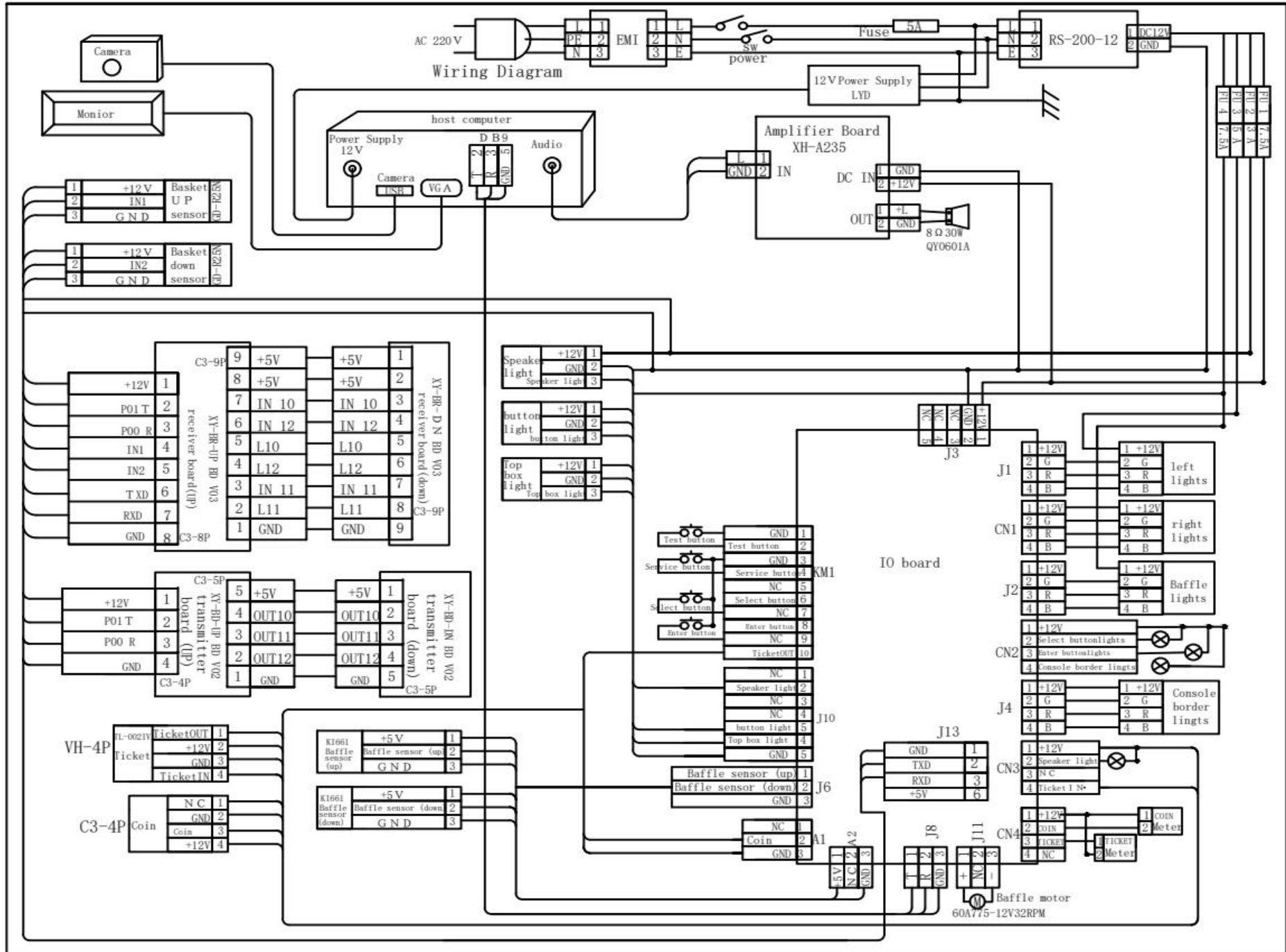

## SPARES AND SERVICE CONTACT INFORMATION

### Sega Amusements International LTD

42 Barwell Business Park  
Leatherhead Road,  
Chessington,  
Surrey,  
KT9 2NY  
United Kingdom

Parts: +44 (0) 208 391 8060 (Option 1)  
Technical support: +44 (0) 208 391 8060 (Option 2)



---

### - PLAY IT AMUSEMENTS -

870 Lively Blvd  
Wood Dale,  
IL,  
60191  
United States of America

Parts/Customer Service : +00 (1) 224 265 4287  
Technical Support : +00 (1) 224 265 4283

